

HIRE and RENTAL Industry Quarterly

JULY 1990

OPEN FULL 7 DAYS

HIRE

KENNARDS

MAKE YOUR JOB EASY!



**OFFICIAL ADELAIDE
CONVENTION
ISSUE**

HIRE and RENTAL INDUSTRY QUARTERLY

JULY 1990

Registered by Australia Post for delivery by post as a newspaper at \$4.00

The Hire System for Hire Returns

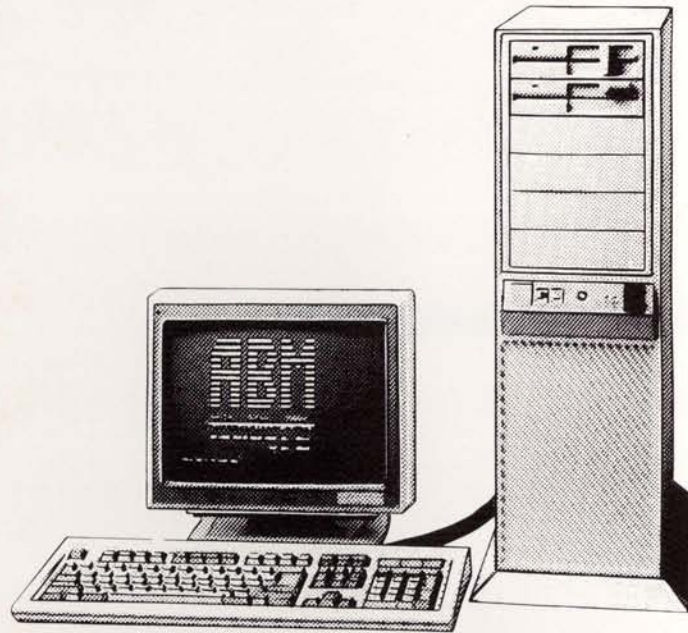

In every field of human endeavour there are "specialists" — in engineering, in medicine, in law . . . or in computers for the rental industry!

It makes sense to talk to the only specialists in rental industry computer systems in Australia —THE SOFTWARE LINK.

The Software Link is managed by people involved in the hire industry in Australia for over 25 years and who have more than 20 years of involvement with computer systems for the Australian hire industry. Over 60 companies in Australia have selected The Software Link for specialist help and advice, training and installations over the past three years.

Whether you are in plant hire, party hire or car hire and you need a Single-user, Multi-user, Front-counter, Back-office, General Ledger or

non General Ledger based system . . .

The Software Link has all the answers and a proven solution for your hire business.

Don't gamble with your business — go to the specialists. When you want a proven solution for a fixed cost, call The Software Link, talk to their friendly experts and discuss with them what you need for your hire business.

For your personal copy of the QUICKHIRE System Overview write to or call

The Software Link

P. O. Box 1, Berkeley Vale NSW 2259.

Telephone 043 - 885133 : Fax 043 - 885035



Hire Association Directory

National Association

President: Pat Pearce (08) 371 0750
Secretary: Rolf Schufft (02) 957 5792
65 Berry Street,
North Sydney 2060.

New South Wales

President: Bruce Fraser, (02) 525 3333
P.O. Box 613,
Baulkham Hills 2153
Executive Officer: Christine Stewart
(02) 634 2964,
Fax: (02) 899 3419

Victoria

President: Michael Conroy 353 4411
Secretary: Lois Ziebell (03) 720 1835,
Fax: (03) 729 7936
12 Rachelle Drive,
Wantirna 3152

Queensland

President: Rod Mansfield (07) 277 1733
Secretary: Linda McInnes (07) 371 9996,
Fax: (07) 371 4117
P.O. Box 1528,
Toowong 4066

South Australia

President: Neil Hallet (08) 336 2466
Secretary: Bob Firth (08) 373 1422
136 Greenhill Road,
Unley 5061

Western Australia

President: Mr K. Baldrey (09) 451 9555,
Fax (09) 458 9092
Wreckair Hire, P.O. Box 569
Cloverdale 6105

Secretary: Mr R. Lowry (09) 277 4144,
Fax: (09) 478 1359
Coates Hire, P.O. Box 154,
Belmont 6104

New Zealand

Director: Kelvin Strong (04) 73 6514
P.O. Box 12013, Wellington

Zone 1 (South Island):

Director: Mr Trevor Tuffnell, Richmond
Secretary: Mrs D. Lusty,
238 High Street,
Motueka

Zone 2 (Lower North Island):

Director: Mr M. Rutherford,
New Plymouth
Secretary: Mr A. Mitchell
Levin Hire Centre,
Main Road South, Levin

Zone 3 (Upper North Island):

Director: Mr G. Craven
Secretary: Mr N. Charlesworth,
Box 51457 Pakuranga,
Auckland

PRESIDENT'S REPORT

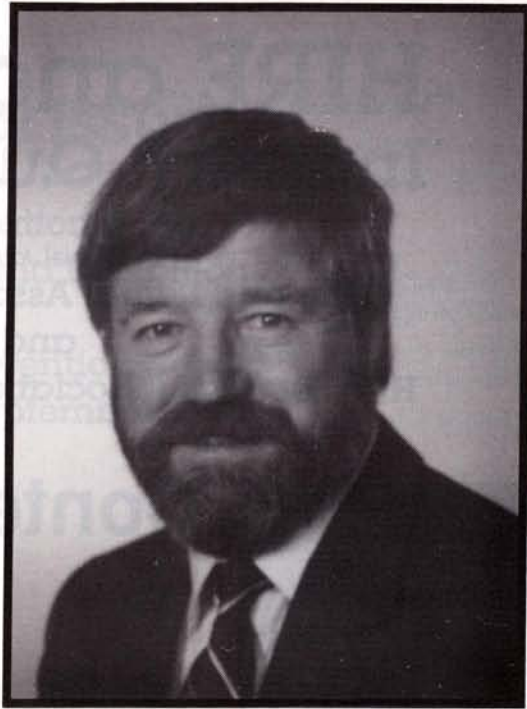

Pat Pearce, National President.

President's Message

I am proud to follow such an illustrious line of fellow Presidents, and hope that I can serve the Association as well as they have done.

Being the first Pommy-Crow-eater-Non-Plant Hire President, I feel particularly vulnerable.

Therefore, my first message will be one of optimism. It is easy when everybody is forecasting misery and mayhem to sit back, do less than usual, and say 'what can you expect in this economic climate' when the figures fall. But - surely our industry is one that can reasonably expect to hold its own during these inclement times. Not all building stops - not all parties are cancelled - not all marketing ceases - life still goes on, and if there is a recession, many of those who have enjoyed the fruits of their labours in the past, will continue on, still building, still partying, etc., and will look to conserve their capital by hiring - not buying.

An over simplistic view - and indeed it may be necessary to simplify the mass of pessimistic fact and figures consistently being thrust upon us by politicians and the media.

In fact maybe a Walter Mitty solution to our 'current problems' would be to close down all media for 3 months. I wonder how the business sector would react if they were not confronted daily with pessimism. There is still a market out there - go get it, and having got it, come and enjoy the companionship of fellow optimists from around this country - and the world at the Adelaide Convention from September 10-14th, 1990.

HIRE and RENTAL Industry Quarterly

Official Journal of the
Hire and Rental Association of Australia
and the
Hire Services Association of New Zealand Inc



Contents

President's Message 1



Editor's Desk 4

Northern Queensland Roundup 6

Occupational Health and Safety 9



Hyatt Regency Adelaide 15

State Roundups 38

HIRE & RENTAL Industry Quarterly

Suite 1, 29 Newland Street
Bondi Junction, NSW. 2022 AUSTRALIA

Tel: (02) 387 7858
(02) 387 7861
(02) 389 7998

Fax: (02) 389 8348

PUBLISHER

Classic Publishing Company
P.O. Box 308
Rose Bay, NSW. 2029
AUSTRALIA

EDITOR

Ken Benson

ADVERTISING MANAGER

Greg Kelson

PRODUCTION MANAGER

Terry McOmish

Official Issue

19th International Hire Convention and Exhibition

Adelaide Convention Centre
10th - 14th September 1990

Feature — At last: special finance

47

Hire gear a winner in Nyngan

49

Party Hire

65

New Zealand Roundup

82

Complete Convention Programme &
Exhibitors showcase

94

Advertisers index

112



PRINTED BY

Bridge Printery Pty.Ltd
29.35 Dunning Avenue
Rosebery, NSW 2018

TYPESET AND LAYOUT

Allette Systems
Level 4, 301 George Street
Sydney, NSW 2000

All statements and opinions expressed in Hire and Rental Industry Quarterly are published only after due consideration of information gained through sources believed to be authentic. No responsibility is accepted for the accuracy of the matter published therein. No portion, in whole or in part, may be reproduced without the written permission of the publisher.

CONTRIBUTIONS AND PRESS RELEASES

Please forward to Ken Benson, Editor,
Hire and Rental Industry Quarterly
P.O. Box 308
Rose Bay NSW 2029.

Rental Calendar

For details of Australian fixtures contact relevant State Secretary from Directory on page 1

AUGUST

- 6-7 NSW Training Seminar
Problem Solving & Decision Making
- 14-16 Hire Services of New Zealand Inc. Annual
Convention & Trade Show - New Plymouth
- 22 NSW Ramset Workshop

SEPTEMBER

- 10-14 S.A. 19th International Hire Convention & Exhibition
Adelaide Convention Centre
- 12-15 Texas Rental Association Convention
San Antonio, Texas
Contact Phil Elam, TRA, 1946 South IH35
Suite 100, Austin, Texas 78704
(512) 440 8388
- 16-19 Rental Association Of Canada Convention/
A.R.A. Region 10 Conference
Winnipeg, Manitoba
Contact Dorothy Wellnitz, R.A.C., 848 Jubilee Ave.
Winnipeg, Manitoba, Canada, R3L 1P9
(204) 452 1836
- 26-29 QLD Industrial Machinery Exhibition

OCTOBER

- 22-25 California Rental Association Convention
San Jose, California
Contact Charles Maltese, CRA, 216 N. East Street,
Woodland, California 95965
(916) 666 4337

NOVEMBER

- 16-18 Hire Association Europe Conference
Bournemouth, England
Contact Mike Hanrahan, Hire Association Europe,
722 College Road, Erdington, Birmingham,
England B44 0AJ
(021) 377 7707; Fax: (021) 382 1743

1991

FEBRUARY

- 11-14 1991 A.R.A National Convention
35th Annual A.R.A. National Convention,
Dallas Convention Centre, Dallas, Texas
Contact American Rental Association, 1900 19th St.
Moline, Ill. 61265
(800) 334 2177

APRIL

- 25-27 Pacific Region Covention - (New Zealand)
Hyatt Regency Hotel
Korolevu Coast of Fiji.

New Chief at Wreckair Hire



Mr Max Williams

A senior Brambles executive, Mr Max Williams, has been appointed General Manager of Wreckair Hire, Australia's largest hirer of plant and equipment.

His appointment follows the acquisition of Wreckair earlier this year by Brambles Industries Limited.

Prior to his appointment, Mr Williams was the Sydney-based eastern region manager of Brambles Equipment which specialises in a wide range of materials handling, earthmoving and other equipment.

Mr Williams said that under Brambles' ownership, Wreckair would continue the strategies which had allowed it to achieve market dominance.

'In particular, we are keen to ensure the continued expansion of Wreckair's national depot network and maintain investment in state of the art equipment,' Mr Williams said.

'Approval has already been given for new depots in Canberra, Perth and Whyalla in addition to the two which will be opened shortly in suburban Melbourne,' he said.

Mr Williams praised Mr Ray Kelsey who joined Wreckair in 1960, became a director in 1972 and served as its Managing Director from 1977 until his retirement earlier this month.

'Ray has made a mammoth contribution to Wreckair and to the hire industry generally,' Mr Williams said.

'Under his leadership, the company achieved market leadership and set standards which few other hire firms have been able to match,' he said.



HIRE
AND
RENTAL
INSURANCE
BROKERAGE
Ltd.

Incorporated in Victoria

JOIN OVER 200 HIEMEN. "HARIB" INSURANCE BENEFITS GO BEYOND "PREMIUM" \$'s

HARIB arranges top insurance cover for *OUR* industry. With insurance due, don't cover yourself short, or pay over the top.

JUST FOUR VALUE PACKED REASONS:-

- HARIB works for Hiremen.
- HARIB is owned by Hiremen.
- HARIB profit comes back to Hiremen.
- HARIB supports Hiremen through the Hire and Rental Association of Australia.

HARIB OFFERS FREE ADVICE ON OBTAINING FINANCE FOR INSURANCE PREMIUMS OVER \$2000. Rate calculated strictly by Credit Act (1984) regulations, so your money earns more *in your business*.

Your future's at stake, regardless of your size, and HARIB has got over 200 successful reasons to prove we're it . . . right across Australia.

Advice and quotation is free.

Branches:

- | | |
|-----------------------------|--------------------------|
| Cairns (070) 31 3150 | Launceston (003) 31 3055 |
| Brisbane (07) 371 9188 | Hobart (002) 31 1288 |
| Coffs Harbour (066) 52 5144 | Adelaide (08) 212 5324 |
| Bankstown (02) 796 3611 | Perth (09) 430 5650 |
| Sydney (02) 601 5333 | |
| Dubbo (068) 84 3103 | |
| Cooma (064) 52 4111 | |
| Merimbula (064) 95 1544 | |
| Warragul (056) 23 5744 | |
| Melbourne (03) 321 8600 | |
| Wangaratta (057) 21 7688 | |

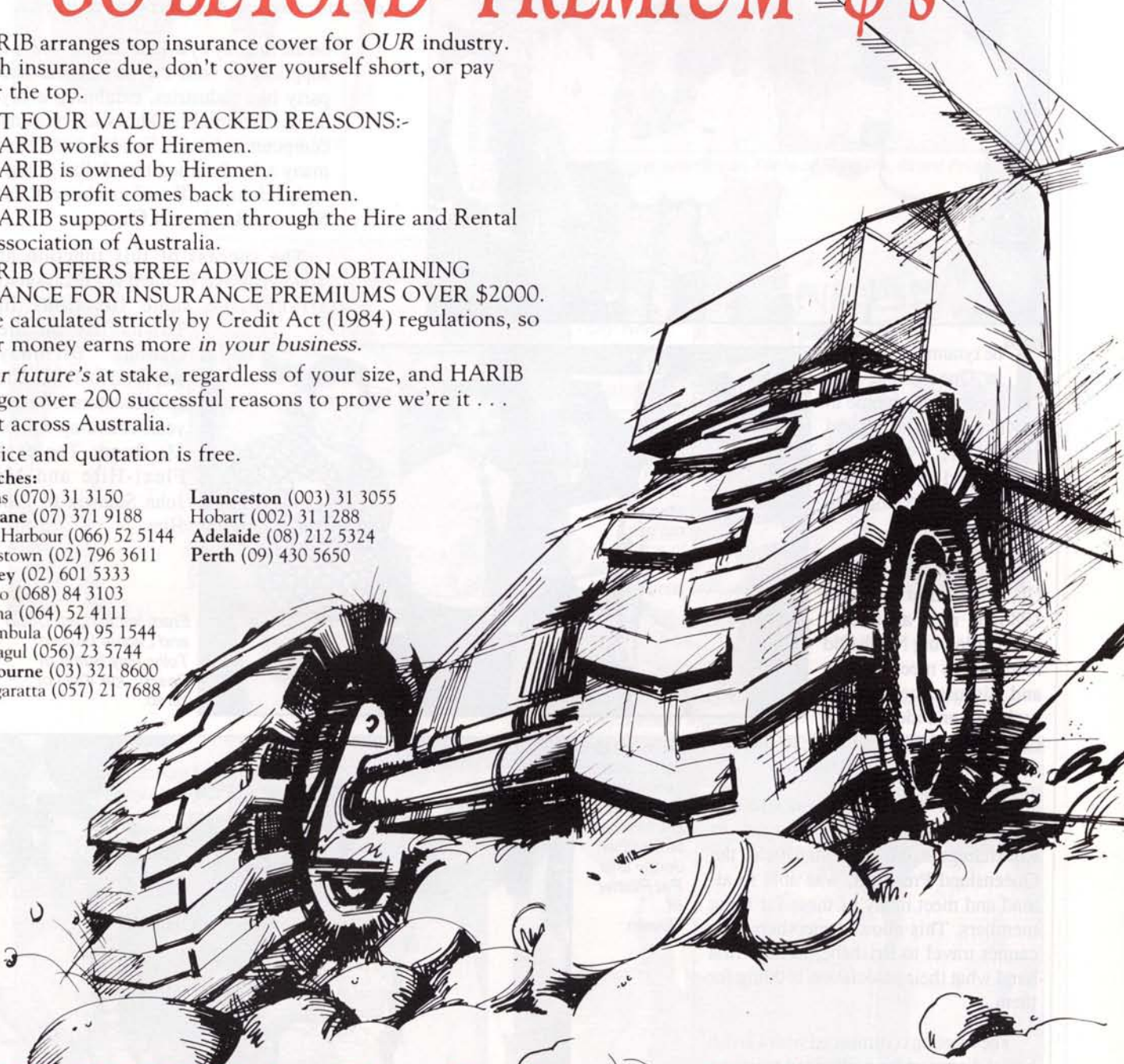

"HARIB": ENDORSED broker of Hire and Rental Association of Australia.

Designed and Produced by AD DAM (03) 555 4462

South Bank Motor Inn, Townsville

Saturday 9th - Sunday 10th June 1990



From left to right: Don and Margaret Neate of Paramount Hire; Stephen Ede of Tully; Narelle Jackson of Cairns; Tom and Anita Jacobsen of Jay Hire.

on the Sunday by a trade display with 21 suppliers to both the mechanical and party hire industries, exhibiting every thing from mini backhoes to tents and computer software. Sunday night saw many a hard earned hire dollar grudgingly left in the "Keno" machines at the Sheraton Breakwater Casino.

The success of this function at Townsville has resulted in a decision to arrange the same functions in

Townsville on the Queens Birthday weekend in 1991. The co-ordinators of next years round-up will be Mr Roger Toole of Flexi-Hire and Mr John Stanwix of Pro-Hire.

The tyranny of distance in Queensland was recently overcome in Townsville on the 9th and 10th June, when 18 Queensland members met at their fourth "Northern Roundup".



From left to right: David and Leonie Barra of Tully; Ray Butler of Bosch; Joe Vella of Hirab.

The Northern Round Up, first held in Cairns in 1986, is now an annual event, allowing North Qld members to meet socially and discuss their varied problems and ideas which can then be conveyed back to the Association executive in Brisbane.

This year's Round Up was attended by members from Port Douglas to Rockhampton. Mr Rod Mansfield, the Queensland President, was able to attend and meet many of these far flung members. This allowed members who cannot travel to Brisbane, to hear first hand what their association is doing for them.

The meeting commenced with a lavish buffet dinner under a silk lined marquee, attended by 86 people. This was followed

From left to right: John Lyons and Raymond Christensen of Cambar; Jenny and Pat Pilcher of Bowen.



South Bank Motor Inn, Townsville

Saturday 9th - Sunday 10th June 1990



Alex and Tammy Hura of Underwood Hire.



From left to right: Roger and Susan Toole of Flexihire; Grant Friis and Leo Quinn of Trilogy.



From left to right: Merv Newnham of Horizon; Tony White and Dan Neate of Paramount Hire.



(left) From left to right: Ken Large and Ian Milton of Cranford Products.

From left to right: Ray Maxwell of Jaden Engineering; Doug Grabs and Terry Mulley of Burdekin Hire.



From left to right: Peter Assenbruck of Mole; Modeste, Rita and Modeste (Jr) Barra of Ingham.



The Hon. John Brown

*Chairman of the Tourism Task Force, Former Minister for Sport,
Recreation & Tourism and Devoted Sports Enthusiast*

Joint keynote speaker Adelaide Convention 1990

Enigmatic and irreverent, John Brown's life is full of contradictions. A successful businessman and politician, the former Minister for Sport Recreation and Tourism is also a salesman, a promoter and a punter. This combination of skills enabled him to mastermind the hugely successful Paul Hogan campaign to sell Australia to the world.

The son of a bus driver, John Brown went into business for himself at the age of 21, having decided a career in Agricultural Science, which he studied at Sydney University, was not for him.

Now he is the owner of a multi-million dollar meat distribution company and an active participant within the meat industry having started the Pork & Bacon Marketing Council - which benefited his competitors more than himself - and served as both a trade unionist (Australian Meat Industry Employees' Union) and the Chairman of the Employers' Association.

John entered politics with the intention of applying business principles to running the country. Once elected, his combination of salesmanship, marketing skills, leadership and a shrewd business sense propelled John into the

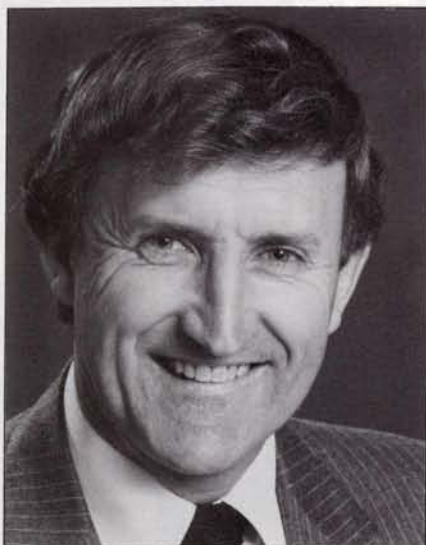

The Hon. John Brown

Ministry.

As Minister for Tourism John helped to turn a small industry into a major economic force when he masterminded an advertising campaign which changed the face of Australian tourism - the hugely successful Paul Hogan "Shrimp on the Barbie" campaign for the US market.

Along the way he collected brickbats as well as bouquets, adversaries as well as awards. One of the former described him as "nothing more than a salesman",

one of the latter was a special Gold Award for Marketing Excellence from the Marketing Institute of Australia.

His love of sport and his commitment to promoting it has also resulted in honours. He has received The Olympic Silver Order of Merit for his contribution to the Australian Olympic Movement and is an International Honoree of the US Academy of Sport in recognition of his contribution to international sport.

John continues to work for things he believes in. The John Brown Foundation established annual awards scholarships to young Australians in both sport and tourism. John is also Chairman of the Tourism Task Force, described by the Prime Minister as the most prestigious industry lobby group in Australia.

As befits a former minister for Sport and Recreation, John Brown has many and varied leisure interests. He loves horse racing, plays golf off a handicap of 10, won the Sydney Morning Herald Garden Competition 3 times, and enjoys the theatre, opera, ballet and cinema.



Cover story

Kennards Hire Service, Sydney, is the first Australian hire company to receive the new Kango model 1400 light demolition hammer. Andy Kennard (right), Managing Director of Kennard Hire Service and his Equipment Manager Mark Zimmer

(left) discuss the features of Kango's latest product with the marketing Manager of Kango Australia, Bill Lewis.

With its dramatic hitting power, totally new concept in design and a cost

saving reduction in servicing downtime, the 1400 has already gained overwhelming support from the construction and building industry in the United Kingdom, the USA and Europe.

Further details on page 32.

Occupational Health and Safety: Investment or Overhead?

by David J McIvor,
Director Occupational Safety & Health Associates (Aust) Pty Ltd

Stock market crashes, international currency fluctuations and a generally increasing concern about our country's economic viability are all pressures which are impacting on an organisation's desire and commitment to occupational health and safety. Never before has the question of whether OH&S is an overhead or an investment, been so important.

Is OHS an **investment** which can be made to the benefit of the organisation and the people who work for it - managers and workers; or an **overhead** cost - about which nothing much can be done but wouldn't it be nice not to have to worry about it. And is OHS an issue about which company directors should be concerned?

If OHS is an investment, we should be able to identify an appropriate return on that investment: at least that is what the accountants would have us believe. It has been the traditional propaganda of OHS professionals - consultants included - that there are dollars to be saved in OHS: but how much truth is there in this idea, or how relevant or appropriate is it to equate good OHS with dollars.

If we say good safety saves dollars, there is the implication that if safety improvements don't save money - or even are not likely to save dollars - then we should not bother: there is no economic justification for the improvement. To many people, the philosophical assumption that safety saves dollars is abhorrent, because of this implication that if the economic disadvantages of safety outweigh the economic advantages, then OHS must fall by the wayside: that there are dollars to be

saved becomes the criteria and the measure for concern.

This is the argument which is raised when we consider whether control of risks to health and safety is "practicable" - as per the OHS Act. Although practicable is defined as having regard to

the nature and severity of the risk
what we know about the hazard and how to control it
the availability and suitability of ways to control,

"practicable" essentially reduces to consideration of **cost**. In effect we have a see-saw: on one end we have risk, on the other end the dollars needed to control the risk. Where the see-saw balances we have what is practicable. A more emotive way of looking at the see-saw is to consider the health and safety of workers being traded off against the dollars needed to protect their health and safety.

... the way to greater success for Australia in the global market is to make better use of our resources ...

Since 1975 in Australia, this trade-off has seen the see-saw weighted to cover the risks to health and safety, but now one suspects that with the economic difficulties facing our country, perhaps the see-saw is tilting back again. The argument seems to be that there are dollars to be saved now by cutting back on OHS measures.

Yet Kodak is one successful company that recognises there is a significant return on investment for the OHS dollar - they estimate a 1.7:1 R.O.I. When Dulux thought this figure excessive and calculated the OHS R.O.I. for themselves, they came up with 10:1! Given that the costs of poor OHS to the country - as estimated by a Federal Senate Committee review - are \$12.5 billion (ie \$50-60 per family per week) then at a return on investment of 10:1, the potential costs to Australia through a national cutting back on OHS are hundreds of billions of dollars per year. Obviously we cannot afford this.

Some economists argue that we must restructure our economy to compete with the South Koreans, the Singaporeans and the Japanese. Yet workers in these countries are paid at the rate of cents per hour rather than the dollars we are used to in Australia. It is my belief that Australian society will **never** accept a drop in our living standards that such wage rates imply. No: the way to greater success for Australia in the global market is to make better use of our resources - in particular our human resources - we have to become cleverer about how we make use of our people.

Economists talk about value added products - instead of selling iron ore, make steel products and sell these. But the critical factor in such added value is the contribution of people: now is not the time to be cutting back on maintenance of our human resources. A company running a one million dollar vehicle fleet would not balk at spending tens of thousands of dollars per year to maintain that fleet; the same company

Continued Page 10

From Page 9

spending millions of dollars on people through salaries etc, frequently does not see the need to maintain and develop those people ie human resources management and development.

In many Australian states, new workers' compensation systems (e.g. WorkCare in Victoria) have led employers to believe that relatively low levy premiums have reduced the need to be concerned about occupational health and safety. Many employers have lost sight of the fact that the true costs of accidents and injuries are many times the costs which can be attributed to compensation, etc.

It has long been stated in the OHS profession that the uninsured/indirect costs of accidents are many times the insured/direct costs. Indeed, this factor has been used as "propaganda" for so long that it has achieved the status of dogma. Several decades ago, the "accident cost iceberg" was used to illustrate that the hidden costs of accidents are much greater than the direct costs, as represented through accident compensation (WorkCare) levies. The contemporary message is the same: the costs of injuries and illnesses to employees represent but a small proportion of the total costs of occupational accidents and exposures.

It is not just propaganda when a car manufacturing company adds over nine hundred dollars to the cost of a car to pay for the accidents and ill health that went into making it; or a semi-trailer manufacturer adding \$5,500 to each trailer for similar reasons - or perhaps a ball-bearing manufacturer selling ball-bearings in Asia, which has 0.01 per cent added to costs - and who consequently loses out to South East Asian competitors.

So far we have discussed the humanitarian/moral justifications for OHS - and the economic ones. Which of these are more persuasive is up to you. But there are more.

In Victoria and Australia, it is the industrial relations reality that employers must pay attention to OHS. Australian unions have listed OHS alongside national superannuation as the two major issues to be tackled by the trade union movement. OH&S is an important issue for trade unions and their

members. The benefits of planned preventive programs which are based on consultative processes with employees and their unions, are important justifications for employers to encourage such programs.

As stated by the U.K. Robens Committee in 1972, the "primary responsibility for doing something about occupational accidents and disease lies with those who create the risks (ie with those who control the processes of production) *and with those who work with them.*"

***How organisations
manage their human
resources will be a
critical factor in
determining whether
those organisations
survive the next 5-10
years in Australia.***

Then there is the legal justification - like it or not, the law (OHS Act) says employers - and workers - must pay more attention to OHS. There are many State and Federal Acts of Parliament and associated regulations and ordinances which place considerable responsibilities on employers. These legal requirements, both legislative and at common law, should be significant motivating factors to employers even though these requirements should be seen as minimum responsibilities only. Unfortunately, the law usually intervenes after injuries, illnesses and deaths occur and therefore is of limited value as a preventive factor.

In Victoria, the Occupational Health and Safety Act does move some of the way to allowing the law to adopt a preventive role. In addition to Codes of Practice describing preventive steps to avoid injuries and ill health at the workplace, the general duty on employers - to provide and maintain a working environment that is safe and without risks to health (as far as practicable) - places considerable onus on the employer to take preventive steps by:

providing safe and healthy workplaces

laying down safe and healthy work systems and procedures

providing for safe and healthy transport, storage and use of plant, equipment and substances

providing for employees, all of the information, instruction, training (in such languages as are appropriate) and supervision AS ARE NECESSARY to enable the employees to perform their work in a manner that is safe and without risks to health.

The key word is "practicable", the definition of which includes reference to the COST of complying with these requirements. As many employers have found - to their surprise - meeting the overheads of OHS in order to comply with statutory obligations, has enabled them to achieve tangible improvements in quality, productivity - and profit. OHS has indeed been found to be an excellent investment.

Some employers complain of the difficulty of complying with the OHS Act. No doubt with some reason - many employers are having great trouble meeting their legal responsibilities. Yet occupational health and safety is just one significant issue in the human resources spectrum which demands attention and action from manager and employee. Many organisations are concerned about their ability to comply with Occupational Health and Safety Acts, yet we must all recognise that the law is only prescribing a **minimum** level of activity and a **minimum** standard in the area of occupational health and safety.

Those organisations which use as their objectives, the achievement of minimum standards (ie as expressed in the OHS Act) will in the next 5-10 years surely fail. The organisation may fail to successfully manage OHS, or the organisation may fail totally and go out of business. The attitudes and strategies developed within an organisation, which allow it to aim for minimum standards in OHS, will be the same attitudes and strategies which allow the organisation to aim for minimum standards

Continued Page 11

From Page 10

in industrial relations, quality control, employee participation and equal opportunity programs: indeed, the whole span of human resources management. How organisations manage their human resources will be a critical factor in determining whether those organisations survive the next 5-10 years in Australia. Investment in human resources - and specifically in the health and safety of those human resources - is an investment in the future.

Whether dealing with occupational health and safety issues or other human resources related concerns, it is critical that organisations set their own standards and objectives to be achieved, which are appropriate for their own particular organisation. Successful organisations, those in search of excellence, will not and cannot afford to set standards and objectives which merely comply with statutory requirements, but do not allow managers and employees to fulfil their personal and organisational goals and objectives.

In addition to the minimum requirements of the OHS Act, we should also note the recent trend for employees to sue employers under Trade Practices Acts rather than under Common Law, to which access has been restricted in Victoria and other States.

Some of the best performing organisations in OHS in Australia, have consciously approached OHS as an investment, not an overhead. Successful companies such as Dulux and Kodak work on the principle that they cannot afford to operate without a commitment to health and safety. Their stated intention is to minimise costs to the organisation, in which case there is no room for recurrence of loss events. Costs of accidents are not buried in administrative areas, but are allocated back to the areas where they are generated. In OHS, they do the common things uncommonly well.

Each organisation has to consider the best OHS Prevention Management Program to meet its needs. (There is no such thing as an "off-the-shelf" OHS

program). Whether that program represents an overhead to the functioning of the organisation, or is an investment by the organisation in its human resources, will determine the extent of the investment and the potential return on that investment. As Mr John Halfpenny has said,

"It is a mistake to treat workplace health and safety as a separate issue from the broader questions of management practices and productivity.

It is our belief (ie the trade union movement) that a lack of imagination, excessive secrecy and a one-dimensional approach by management lies behind the decades of inaction on occupational health and safety."

We have as our focus people - whether they are managers, supervisors, or shop floor workers, is incidental. An investment in OHS is an investment in people - how can that be an overhead?

Boss sideloaders released

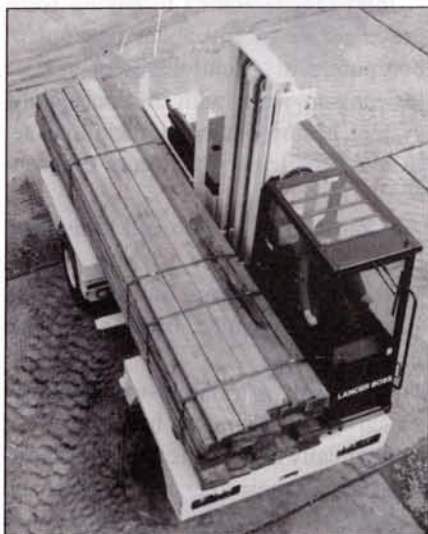

Boss sideloaders.

The Boss range of sidelifting trucks has been recently released to Australian market by Clark Equipment Australia.

Sideloaders provide an efficient method of handling long loads, in industries with either long or short travel

distances. Various platform widths and lifting capacities, make this product suitable for most long unit loads.

Boss sideloaders are the most popular in the world, with a significant number already operating in Australia.

Currently the Boss range covers 24 various models with capacities ranging from 2 tonnes to 45 tonnes. The most popular size is the mid-range capacities of 3 to 5 tonnes. Boss models in this size range have reduced work cycles times aided by features such as: powered fork lowering, platform/mast tilt, elimination of stabiliser jacks.

Boss side loaders are easy to drive. Automotive controls, light and tight steering, large brakes and functional full cabs with tinted glass, wipers and suspension seats assure maximum productivity over a full day.

Clark Equipment Australia

welcome enquiries from both existing and intending customers in respect of new products, services or service part matters. Contact:

Clark Equipment Australia Pty Ltd,
Product Manager: John Corry

Tel: (02) 477 8435

Fax: (02) 476 2241

or write to P.O. Box 50

Hornsby NSW 2077.



Boss sideloaders.

Quickhire Advanced Rental Management System

The Computer System to solve hire management problems for plant hire, handyman, party hire, electronic equipment and truck and car hire.

A NEW computer system is now available that is reported to take the mis-management, guess-work and the headache out of day-to-day running of the hire and rental industry.

Known as the "Quickhire Advanced Rental Management System" Version 5.0, it is supplied and supported by The Software Link Pty Ltd who, with over 70 sites, claim to be the leader when it comes to software management packages for the Australian hire and rental industry. This is reinforced by the list of clients who have used The Software Link technology to solve their hire management problems, including Wreckair, Atomic, Hire It, Moorland, etc.

The benefits the Quickhire system is said to offer include such things as front counter contract and inventory management including re-hire management, RDO's, stand downs, break downs, automatic month end roll-over invoicing, depreciation, schedule 7 taxation reporting, multi location and multi company with on-line system capabilities.

According to Chris Pannell, the managing director of The Software Link; "the Quickhire system has been developed from the ground up over 7 years and, unlike a lot of so called rental systems, is especially designed for rental management and is not just "stuck on" to an existing accounting package".

It is a fact that rental companies sell "time" rather than just sell a machine. The accountant and the business owner insist upon an accurate record of all hired equipment is kept. This is very important in an industry where "lost time" is lost dollars.

"Quickhire is designed to 'track

time', which is what the hire industry is all about," said Pannell, who has 30 years experience in the industry, and, as the Coates State Manager, whose profit figures in NSW were instrumental in the ANI takeover of Coates in 1972, ought to know what he is talking about.

"The System provides for total rental contract and stock control and multi location from the quotation stage through to reservations and bookings to on-hire contracts, automatic invoicing and charge calculations upon return or at the end of the month," he said.

"Quickhire is designed to 'track time', which is what the hire industry is all about,"

Quickhire is said to offer the user a wide range of functions specifically suited to the hire industry. As well as offering such things as stock control, asset management, revenue and expense reports and balance sheets in accordance to Australian Schedule 7 accounting standards, and a number of other features.

One of the many companies that has installed and now has its branches linked by the Quickhire system are Atomic Hire Centres, who have branches in Sydney, Melbourne and Brisbane.

The main function of Atomic's business is the hire of general purpose equipment to builders and handymen, in some branches they handle hundreds of transactions daily.

Atomic is reported to have a large number of clients which obviously have a diverse range of needs. Thus Atomic have a lot of machinery to keep track of along with a large number of contracts and invoices to get out.

John Morris, managing director of

Atomic Hire Centres Pty Ltd, believes that the Quickhire System has taken out all the guess work involved in the day-to-day running of his business.

"The Quickhire System is so easy to understand and operate that no new people have had to be employed," said Morris, "we just trained those who in the past had carried out the manual tasks that Quickhire has now replaced. All we've really done is replace pencils with keyboards.

"Quickhire is a tool that allows for complete control over profit and expenditure, stock control, credit control, debtors utilisation, as well as inter-branch and inter-state transfers. The computer will report on our revenue to date on existing hires even daily if we need it."

"In today's economic climate, you can't have this sort of information on just a month-to month basis, it must be day-to-day to ensure the success of your business," he said.

John Morris admits to having some pre-conceived myths about the worth of computers at Atomic, however after learning to work with and accept the system, he now believes Quickhire is set to take Atomic into the twenty-first century.

Atomic Hire introduced Quickhire to its Sydney office in May of last year, and have since had it installed into both their Brisbane and Melbourne offices.

The result is a nation-wide link between all of Atomic's branches. This dramatically improved communications between all their interstate offices, and has given Atomic both healthier management and profits.

A special version of the system is available for Car and Truck Hire.

Further information:
The Software Link Pty Ltd,
P.O. Box 1,
Berkely Vale, NSW, 2259
Tel: (043) 88 5133
Fax: (043) 88 5035

RE-ENGINE

YOUR FLEET WITH

Lister

**AIR-COOLED DIESELS
WATER-COOLED DIESELS
PETROL ENGINES**



- Lister-Petter has the lowest life-cost engines in their class.
- Deal direct with the manufacturer. Branches in every mainland state. Servicing dealers in all country centres.
- Unrivalled parts support throughout Australia.
- Wide range of models – 32 engine types under 130hp and 22 of them under 50hp to suit every application.
- Free technical advice.

Telephone for more information.



LISTER-PETTER AUSTRALIA

Head Office: 65 Marigold St., Revesby N.S.W. Tel.: (02) 771 4911
Qld.: 316 Evans Road, Salisbury North 4107. Tel.: (07) 277 6311
Vic.: 12/2 Sibthorpe Street, Braeside 3195. Tel.: (03) 587 2988
S.A.: 81 Grange Road, Welland 5007. Tel.: (08) 340 1844
W.A.: 155 Abernethy Rd, Belmont 6104. Tel.: (09) 479 1460

LP121

HIRE and RENTAL - JULY 1990 - 13

BREAKING NEW GROUND IN THE 90's

THE P-130 WD PORTABLE COMPRESSOR

FROM INGERSOLL - RAND

- POWER FOR TWO 25KG PAVING BREAKERS
- POWERED BY THE DEUTZ F3L1011 DIESEL ENGINE



Melbourne (03) 794 1611
Adelaide (08) 352 6122
Kalgoorlie (090) 93 1647

Hobart (002) 72 6621
Darwin (089) 32 2950
Townsville (007) 25 1660

Sydney (02) 648 5055
Perth (09) 277 2211
Brisbane (07) 277 3511

INGERSOLL-RAND
CONSTRUCTION EQUIPMENT

Hyatt Regency Adelaide - Convention Accommodation

ADELAIDE
90

Hyatt Regency Adelaide, the proud recipient of the 1989 State Bank Tourism Award for best International hotel, is ideally located in the heart of the city.

The hotel is comfortably adjacent to the Adelaide Casino, the Adelaide Festival Centre, the Adelaide Convention Centre and Exhibition Hall, thereby enabling guests to enjoy 5-star accommodation plus the best of the cultural and entertainment aspects of this beautiful city, close at hand.

Regency Club - A hotel within a hotel occupies the top atrium, where 4 floors of exclusive accommodation are located

under a glorious glass domed skylight.

In the privacy of the dramatic Regency Club Lounge on the 21st floor each guest is accorded a personal welcome and can expect the concierge to pay special attention to personal preferences and needs. This often begins with guest room registration that conveniently bypasses the Front Desk.

The Regency Club concierge is thoroughly familiar with the local destination, giving travel directions, sharing shopping tips, making dining reservations or booking organised tours and theatre attractions. Appointments can be confirmed and transport arranged.

Guests can enjoy complimentary continental breakfast, beverages during the day and hors d'oeuvres and aperitifs in the evening.

As guests of Regency Club, further benefits are available including a welcome amenity in the room and a personal

butler service.

Regency Club guests are also entitled to complimentary access to Hyatt Regency Adelaide's fitness centre "Nautilus at the Hyatt" which offers sauna, spa, steam room, heated swimming pool and a work out room boasting an extensive range of time efficient patented Nautilus equipment. Priority access is also given to Waves, Hyatt Regency Adelaide's exclusive nightclub featuring the most advanced video, sound and lighting technology and to the neighbouring Adelaide Casino, regarded as Australia's finest.

Regency Club's 4 floors of accommodation include 54 Regency Kings, 7 Regency Twins with the 24th floor devoted exclusively to suite accommodation.

Regency Club is ideally suited to cater for the needs of business people, providing an elegant forum for informal after-hours relaxation.

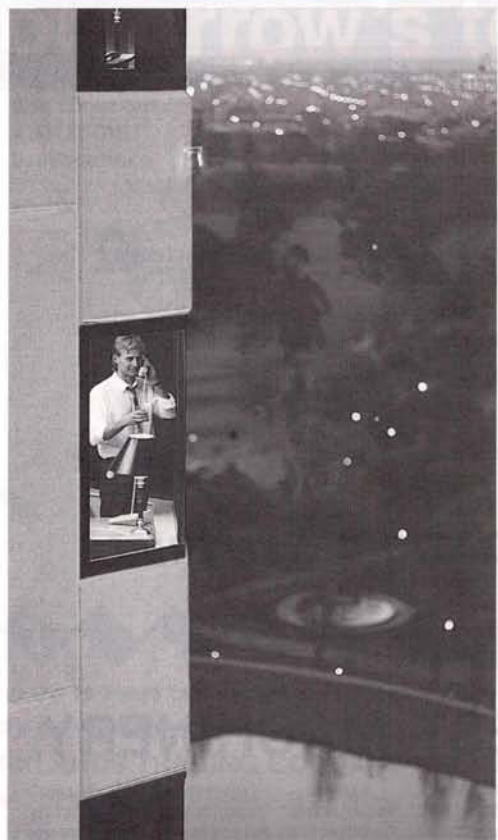

You are invited to experience the best of the best.

The standards of excellence at Hyatt Regency Adelaide are a matter of record. But high atop this magnificent hotel are four floors which are considered to be the best of the best.

They are called Regency Club. These floors are quite separate and self-contained from the rest of the hotel. In the privacy of the Regency Club lounge, sit beneath the spectacular glass dome and enjoy complimentary breakfast and evening cocktails with hors d'oeuvres.

The concierge is always on hand to arrange anything from a flight around the world to a flutter in the normally restricted International Room at the Casino next door.

Add to this, complimentary use of the fitness centre, 24 hour laundry and dry cleaning and a fully equipped business centre and we are sure you'll agree our Regency Club is the best of the best. For reservations and

further information call (08) 231 1234.

HYATT REGENCY  ADELAIDE

Hyatt welcomes you in Sydney, Melbourne, Canberra, Adelaide, Perth, Sanctuary Cove and Coolum. For reservations at over 150 Hyatt hotels and resorts worldwide, please call - In Australia 008 222 188 - In Sydney (02) 327 2679.

NEW

AIRLETE

PORTABLE AIR COMPRESSORS

- ADVANCED TECHNOLOGY
- DEPENDABLE OPERATION
- FROM 100 to 370 C.F.M.
- CONSTANT EFFICIENCY
- GUARANTEED RELIABILITY
- SERVICE COMMITMENT

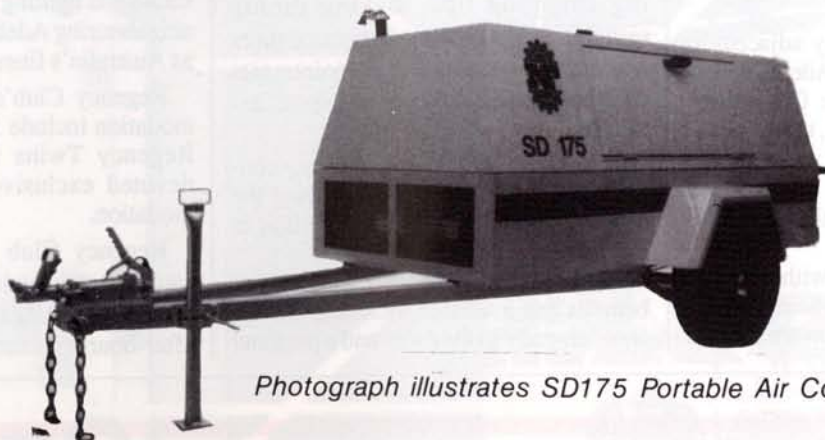

Photograph illustrates SD175 Portable Air Compressor

STANDARD FEATURES

- Gardner Denver rotary screw compressor with modulating inlet valve.
- Thriftmeter—stepless control system.
- Engine jacket water and compressor oil cooler.
- Donaldson Cylopac two stage single element air cleaner.
- Control Panel with auto-shutdown.
- 10 micron full flow compressor oil filter.
- Minimum pressure protection.
- Two wheel single axle trailer with mechanical over-ride brakes.
- Full sheet metal acoustic canopy with access doors and removable top section for servicing.
- Centre lifting bail.

DON'T TAKE ANY CHANCES . . . !
CONTACT TODAY FOR AN OBLIGATION FREE TRIAL

Your Air of Confidence



NOBLETT & FORREST MACHINERY

ADELAIDE
Ph (08) 260 2788
Fax (08) 349 4142

SYDNEY
Ph (02) 726 7499
Fax (02) 727 2059

MELBOURNE
Ph (03) 314 5133
Fax (03) 314 0431

PERTH
Ph (09) 378 1999
Fax (09) 279 7815

BRISBANE
Ph (07) 877 6060
Fax (07) 877 6092

DARWIN
Ph (089) 84 3155
Fax (089) 84 4302

LAUNCESTON
Ph (003) 26 3033
Fax (003) 26 5983

AUCKLAND
Ph (09) 274 5212
Fax (09) 274 8909

What is Equipment Finance

- By Bill Carney
Business Development Manager
Commonwealth Development Bank

The Commonwealth Development Bank (CDB) provides equipment finance by way of hire purchase or consumer credit (both instalment credit arrangements) for the acquisition of new or second-hand machinery, equipment and vehicles used by primary producers and business undertakings.

Most standard types of goods are financed including - tractors, earthmoving equipment, harvesters, ploughs and other farm machinery; industrial machinery including lathes, grinders, forklifts etc; commercial equipment including cash registers, computers, refrigeration equipment, x-ray and dental equipment as well as trucks, buses, vans and other vehicles, and cars for business purposes and primary producers. This list is by no means exhaustive.

The customer deals with the supplier

in the normal way by paying a deposit by cash or trade-in and deals direct with the Bank regarding the financial arrangements.

All types of farming and grazing enterprises as well as all business undertakings can apply for equipment finance, including, for example, businesses engaged in engineering, transport, road construction, food processing, printing, retail trade, tourism, building, doctors and other professions, service industries and sports centres.

Applications are lodged at any CDB State or Regional Office or with any branch of the Commonwealth Bank. Customers of any bank may obtain finance from the CDB without disturbing existing banking arrangements.

Instalments are normally paid monthly but special arrangements may be made to coincide with receipt of seasonal income. Deposits and terms are flexible and balloon payment at the end of the term can be considered if the customer so wishes.

Interest rates are kept as low as prac-

ticable. The rate is fixed for the term of the contract. There are no establishment; commitment, pre-payment of service fees and rebates of terms charges are allowed on those early termination occasions. A security deposit is not required nor is security over real estate or other assets sought or taken.

Equipment finance preserves the customer's working capital. However, payment of a deposit naturally reduces the interest charges and instalments. Term charges, normal depreciation and any investment allowance are all tax deductible.

Payments are debited automatically to the customer's existing cheque account. The balance sheet of the business will include equity in the equipment as an asset.

CDB's equipment finance arrangements provide an economical, quick and easy means of financing equipment purchases. To obtain a quote or more information, CDB can be contacted - toll free - on 008 011164.

Tomorrow's tools for today's jobs

Ask about our
AUTOSTART™
Brushcutter



12 Model
Brushcutters



NEW 2.5 hp Models

ENGINE DRILLS



NEW 26 cc
Model Drills



CHAINSAWS



8 Professional
Models

1 & 2 man
Augers



2 & 5
YEAR HOMEOWNERS
WARRANTY ON ALL PRODUCTS.
2 & 5
YEAR WARRANTY
ON THE ELECTRONIC
IGNITION

Ask about our **WINTER SPECIALS**
on Drills, Augers & Chainsaws.
Plus, our **FREE Safety Kit.**

**Proven rental unit chosen for
Government contracts**

PARKLANDS TRADING COMPANY PTY. LIMITED

NSW: 71 Chapel Street, Lakemba 2195. Phone: (02) 758 2111 Fax: (02) 759 7844

VIC: 1/15 Parkhurst Drive, Knoxfield 3180. Phone: (03) 801 7717 Fax: (03) 801 9253

WA: Unit 3/200 Balcatta Road, Balcatta 6021. Phone: (09) 344 4748 Fax: (09) 349 0339

QLD: Enquiries (07) 807 1333 Orders (008) 224 270 Fax: (07) 807 4232

Parklands

21
YEARS
NATIONAL
DISTRIBUTION

Tanaka

PART108h

Fleurieu at Hyatt



Hyatt Regency Adelaide's premier restaurant Fleurieu draws its name from one of the State's most popular regions - the Fleurieu Peninsula.

Fleurieu offers a truly memorable dining experience in light, airy surroundings. The renowned degustation menu, created by Chef Urs Inauen, is a five-course set menu, devised each day from the pick of South Australia's freshest produce. Alternatively an a la carte menu which changes bi-weekly, is available.

Whatever the choice, an award winning South Australian wine from Fleurieu's exclusive wine cellar will perfectly complement this culinary delight. Fleurieu is open for lunch Monday - Friday, and dinner Monday - Saturday.

For an atmosphere distinctly Japanese, Hyatt's Shiki Restaurant offers both Tempura and Teppanyaki Cuisine. The Teppanyaki tables ensure lively conversation and a front row view of their masterful preparation of traditional Japanese Cuisine. Shiki welcomes you for dinner Tuesday to Sunday.

Riverside Restaurant provides Alfresco dining from early breakfast, lunch, dinner and supper. A sumptuous buffet or à la carte menu awaits the guest who enjoys dining in a more casual environment. Riverside is open every day of the week.

Convention Accommodation

Hyatt Regency Adelaide
(adjacent to the Adelaide Convention Centre),
North Terrace, Adelaide.
Telephone: (08) 231 1234.

Single, Double or Twin room \$165
Triple \$195

Executive Suite/Hospitality Suite \$275
comprises King sized bedroom,
en-suite bathroom and lounge.
An inter-connecting Double or
Twin room can be reserved at the
additional charge of \$165, should a
corporate group wish to avail
themselves of the Hospitality facility.

A tough new breed of construction booms



When the going gets tough, the Simon-Abbey Constructor really gets going.

This heavy-duty, self-propelled articulated boom has features such as 4-wheel drive and 180° hydraulic platform rotator as standard... because it's designed for the construction marketplace. Add "up and over" access, working heights to 14.33m, full pressure hydraulic controls, zero tailswing design, a 10kph travel speed, and 15°/27% gradeability and it's easy to see why the Constructor is the ideal boom for the construction site - under roof or outdoors.

Simon-Abbey is the one company that has the proven equipment to cover all your high reach access applications.

SIMON-ABBEE PTY. LTD.

98 Fairbank Road, Clayton 3168.

VIC: (03)551 8866 Fax: (03)551 5723

NSW: (02)648 4199 Fax: (02)647 1194

WA: (09)350 6488 Fax: (09)451 6907

QLD: (07)277 3588 Fax: (07)277 8717



SIMON



MAKING

TRACS

THE COMPLETE HIRE SYSTEM



TRILOGY

BUSINESS
SYSTEMS

NSW BRUCE DAVIES (02) 692 8688 QLD LEO QUINN (07) 371 6311 VIC DAVID BROWN (03) 690 4000
SA PAUL KRISTORIS (08) 234 2000 ACT KEITH RITCHIE (062) 39 1650

Dr Neville Norman

Economic Adviser and Commentator "Entertaining Economics"

Joint keynote speaker Adelaide Convention 1990

One of Australia's leading economists, Dr Neville Norman has an impressive range of experience at all levels of business, industry and government. His depth of economic understanding, combined with a talent for communication, makes him a rare creature - an academic who not only understands the real world, but can explain the relevance of the latest developments equally well to the man in the street or the MD of a specialized business.

Never dry or dull, Neville presents his facts and figures on the economy and future trends in a style which is entertaining as well as highly informative and relevant.

Positions currently held:

- Senior Economic Adviser to the Committee for Economic Development of Australia
- Economic Counsellor for the Australian Institute of Management
- Director of the Hannan Group Financial Services
- Member of the Ratings Committee of Australian Ratings limited, Standard & Poors Corp.

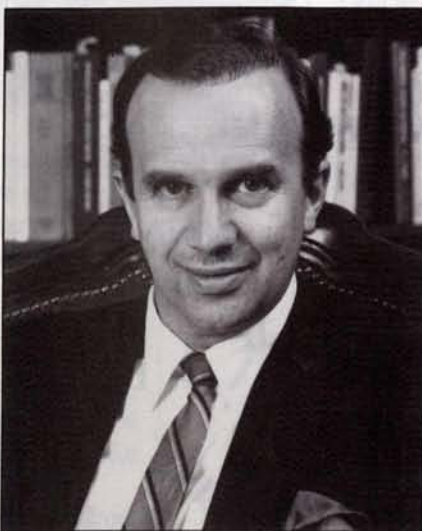

Dr Neville Norman.

- Member of the Trade Practices Committee of the Law Council of Australia
- Member of the Economics Committee
- Consultant to the Legal Committee of the Business Council of Australia
- Investment Advisor to the Transport Accident Commission of Victoria
- Economic Consultant to several companies and financial institutions

Neville Norman has first-class honours degrees in Economics from the

University of Melbourne and a Doctor of Philosophy degree from Cambridge England. Neville is Reader in Economics at the University of Melbourne. His research and teaching has centred on aspects of industry and international economics and industry regulatory policy.

Because Neville makes economics exciting he is in constant demand by the media and for expert economic analysis. He provides regular economic commentary and analysis for both the ABC and commercial television and radio including The 7.30 Report, ABC radio's morning show, AM, PM, and News Commentary. He is also a regular contributor to the Melbourne Herald Business Essentials and other financial publications.

Between all these commitments, Neville has managed to write several books and articles on Micro-Economic Theory; Personal Tax Escalation; Industry Regulation and The Economics of Immigration and Economic Policy.

Neville also speaks several European languages and is a master builder - and a former professional musician!



The brickies' best mate!

It comes with either a 5hp petrol or a 11/2hp drip proof, single phase, flameproof electric motor. Both machines are completely portable and the mechanism can be used either on the supplied stand or on your own work bench.

The saw comes in two sizes - one for the 350mm, and one for the 500mm blade. It

can be used for wet or dry cutting, and accessories include a flexible water pump for use when there is no easy access to water, or when conditions prohibit the use of running water. It can be operated by engaging either the hand lever or the foot pedal. It's ideal for single cuts, but high volume cutting is made much easier by attaching the angle jig - thereby enabling you to

make as many identical cuts as you like from just one adjustment.

The Bianco Saw cuts your work in half and is a must for all those who work with masonry. Available in all colours for fleet management.

Contact: Bianco Builders Hardware
178 Gorge Rd, Newtown, S.A. 5074
Tel. (08) 336 6666,
Fax. (08) 336 6429

You'll burn out before they do.



- **SDS+ Drive**
- **Variable Speed**
- **Lightweight & Compact**
- **Auto-Stop Carbon Brush**
- **Torque Overload Safety Clutch**
- **Efficient Electro-Pneumatic Mechanism**

CONSTRUCTION STRENGTH POWER TOOLS THAT KEEP ON ... KEEPING ON!

For more details on our hire strength tools visit the following specialist Hitachi Exhibitors:

Flextool (Aust) Pty Ltd
Tel: Head Office (03) 419 6300

Rental Industry Equipment Supplies
Tel: (03) 850 2316 or Toll Free: (008) 33 8114.

Also view the comprehensive range of quality Hitachi Power Tools at the Hitachi Exhibition Stand.

The management and staff of Hitachi Sales Australia Pty Ltd wish you a pleasant and profitable convention.
We look forward to meeting you in Adelaide.



QUALITY POWER TOOLS
Tel: Head Office (03) 555 8722

Kubota promotes smart operators

Kubota, Australia's leading tractor sales organisation is set to launch an innovative programme for users of its products.

The Construction Equipment Division, headed by Rudi Heitbaum (General Marketing Manager), has devised what is called the "Kubota Smart Operators Club".

The main theme behind the "Club" will be to promote the effective use of Kubota Mini Excavators and Wheel Loaders.

To outline just what the club will provide to existing owners Mr Heitbaum commented that, "Kubota will provide a number of real service benefits, for example seminars on small business management."

Kubota and its dealers are offering owners and operators of its equipment the opportunity to attend a series of regular seminars on how to maximise the return on an investment in a Kubota



Mini Excavator.

Guest speakers will outline case studies which will enable participants to compare and decide on the most successful and profitable operating procedures for their business.

Financial advice and bookkeeping

The seminars will cover everything from taxation to financing and advice on these subjects will be offered by experienced experts.

As an owner operator many do their own books and in this area Kubota will provide sound practical guidance. Accountancy experts will

explain and outline methods of bookkeeping to enable small operators to manage their business. For example to organise cash flow, evaluating the current position at any item and maximising business profits.

Newsletter

A regular newsletter will keep Kubota owners up to date. It will include a host of valuable information on say new attachments.

Further, it will give ideas how to put Kubota's Mini Excavators to work more profitably.

Through the newsletter, Kubota will provide details on new models and when they will be available and trends in overseas markets. The newsletter will also provide information and facts which will further assist operators to maximise return on their investment in a Kubota Mini Excavator.

Continued page 23

The dinosaurs are dead.

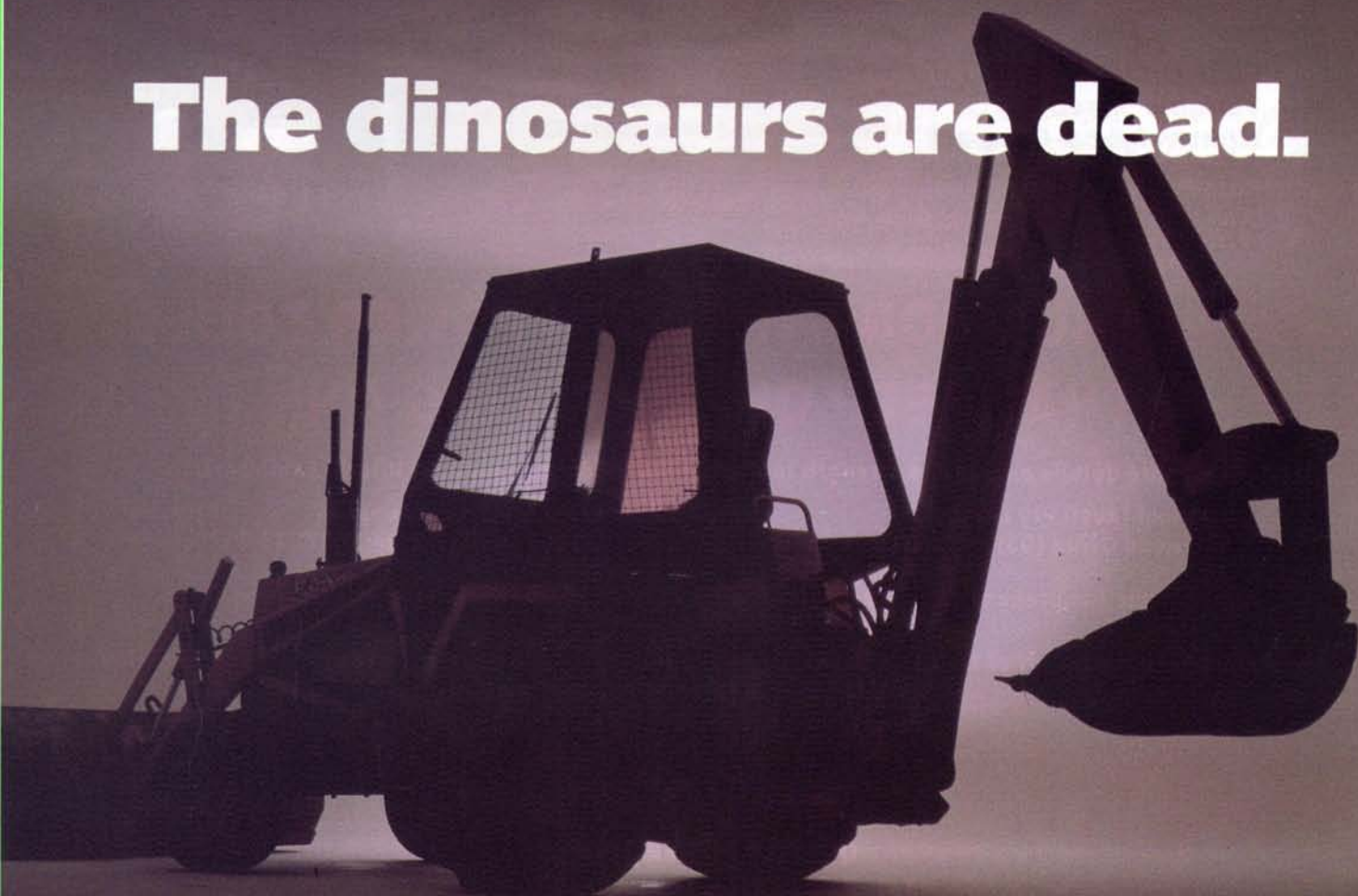

From page 22

Club members will also enjoy periodical special prices on selected service items.

Promotional material

Promotional items will be readily available through all Kubota dealers. These include everything from jackets and caps to stubbie holders.

Operators can use them to reward their customers for choosing to use their business.

Advertising

Kubota dealers will provide "Club" members with advertising material to promote their business and in particular that they are using a Mini Excavator.

Why is Kubota doing all this?

Kubota is keen to put as much back into the industry that supports it as a company as possible.

The Smart Operators Club is just one more way that Kubota is "Putting Technology to Work".

Tracs for better rentals

Better Rentals was the first TRACS Rental site in Victoria for Trilogy. The agreement was signed on the final night of the Hire and Rental convention held in Melbourne in mid September, 1989.

Better Rentals is a growing general rental company with two branches serving the outer south eastern suburbs of Cranbourne and Pakenham. From its inception three and a half years ago, Better Rentals has grown from a staff of one, to employing nine people in two branches.

With such a wide range of stock now available for hire and a significant increase in business, Better Rentals sought a computerised Hire and Rental Management System.

Since going live on the front counter in March this year, Better Rentals have found the TRACS system to be an invaluable tool,

especially in respect to credit and equipment control.

Quoting General Manager, Steve Ashenden. "With bad debts at an alarmingly high figure, we know exactly where we stand with our so called good clients before they rent more equipment from us. Along with automatic invoicing at the end of the month, the TRACS system has enabled us to use our staff more effectively in providing a better service to our valued customers."

On questioning his decision, Bob Field the Managing Director said that, "After careful consideration of all alternative packages available, the Trilogy package was by far the best."

ADELAIDE
90

Cost comparisons tell the story.



Dollar for dollar, feature for feature, Kubota Mini Excavators have ended the reign of prehistoric backhoe loaders.

For around \$64,000 plus sales tax, you own a Kubota KH151 which will soon show you a return of around \$55.00 per hire hour (\$2,200 per 40 hour week). On the other hand, a backhoe loader costs around \$72,000 plus sales tax and the operator can expect an average return of around \$45.00 per hire hour (\$1,800 per 40 hour week).

That kind of cost efficiency comes only from Kubota's legendary technological prowess.

Look through your pocket. It's a convincing view.

Call your Kubota dealer now.

NSW: Gough and Gilmour Pty Ltd: (02) 519 4144

VIC: William Adams Pty Ltd: (03) 566 0666

TAS: William Adams Pty Ltd: (002) 490 566

SA: Kubpower: (08) 261 8811

QLD: Willtrac: (07) 375 5988

WA: Lifrite Pty Ltd: (09) 455 2077

NZ: Gough, Gough & Hamer Ltd: (03) 495 659

KUBOTA

CONSTRUCTION EQUIPMENT

Putting technology to work.



The MIGOMAG 240.

MIGOMAG Cuts Hardsurfacing Costs

The MIGOMAG model 240 Heavy Duty single phase MIG welder has impressed a Shire Council with its versatile features.

The Cockburn Shire Council purchased a MIGOMAG 240 to hardface the compactor wheels on its loader at the waste disposal yard and found significant cost savings.

MIGOMAG's MIG welders have proven extremely popular with the rural sector because, as machines that connect to a 240 Volt single phase outlet, they do not require the installation of expensive heavy duty wiring.

This feature makes the MIGOMAG single phase MIG welding machines attractive for site work or jobs in remote locations.

Cockburn workshop foreman, John Twiss, says the purchase of the MIGOMAG 240 MIG welder has enabled the Shire to carry out its own hardsurfacing on the compactor at a price far more attractive than previously, when work had been contracted out to private companies.

Mr Twiss says welding can be carried out in the yard during periods when the compactor is not operating or at weekends, thereby minimising downtime. Cleaning down, disassembly, reassembly and transports costs have been eliminated as well.

Esperence and Bayswater Shire Councils also have purchased MIGOMAG 240 MIG welders. Spokespersons for the Shire Councils commented that, "the MIGOMAG 240 was chosen because it could be taken out of the workshop and used for repairs and maintenance in the field".

SPECIAL PRICES
On Ex-Stock Models
8kVA
Lister Powered

HYLITE

MOBILE LIGHTING TOWERS

- * Simple and precise control of mast operation with powered hydraulics, extendable to 9 metres.
- * Lights adjustable through 360°, at the press of a button. Supports 4 or 6 lights with total power up to 9000 Watts in Tungsten Halogen, Mercury Vapour, Metal Halide or High Pressure Sodium.
- * Screw jack stabilisers and jockey wheel for fast, safe and easy trailer positioning. Draw bar is detachable, for storage or use in confined spaces.
- * Two auxiliary outlets for powering on-site equipment. Lockable, removable, hinged doors, ample weather protected storage for lights and tools, plus a 60 litre fuel capacity.
- * Mast and trailer from heavy gauge steel, fully galvanised for lasting corrosion protection.
- * Torsion bar suspension, brakes and 13 inch wheels provide trouble-free towing on highways and in remote locations.
- * Models from 5 to 20kVA, with 1 phase or 1-3 phase output, powered by super reliable Lister air-cooled, or Kubota water-cooled diesels, with push button start and anti-vibration mounts for smooth, quiet operation.
- * Versatility, dependability and excellent operator appeal. Ideal for Hire fleets, Mining, Road, Rail or Port work, Construction, Utilities or Emergency.



Don't fumble in the dark!..
Talk to us today...

INCORPORATED IN NSW
ADVANCED
POWER PRODUCTS
PTY. LIMITED

Today's Power Systems with Tomorrow in Mind

Head Office & Manufacturing - 27 Shepherd Street, Liverpool NSW 2170
 Sydney ☎ (02) 600 6555 Fax (02) 821 1936
 Melbourne ☎ (03) 428 1429 Perth ☎ (09) 344 3376
 Brisbane ☎ (07) 844 4511 Adelaide ☎ (08) 349 6333

Hire Industry mourns Fred Wallis

The passing away of Fred Wallis, at the age of 83 on Sunday July 15, after a long battle with illness has left many in Australia's Hire Industry saddened by the loss.

Although he retired from the business some 20 odd years ago, Fred made a great contribution to the fledgling industry.

As an inaugural member of the Hire Association of new South Wales, Fred played an active role in

formulating the guidelines and industries regulations under which we all operate today.

Fred Wallis established his own hire company, St George Plant Hire back in the very early sixties, and since his retirement this business, now St George Rentals, has continued to prosper in the hands of his son Rob.

To those who knew him personally, Fred was a tireless hardworking

pillar of the industry who carved a niche for himself and his company in a new industry.

To those who knew him only by reputation, he was an example to be followed.

We extend our deepest sympathies to Fred's wife Jean, sons Ron and Rob and families and express our pride in having been honoured by his involvement in our industry and our lives.

CLARK

"TRUE BLUE" FORKLIFTS!

LEADER

"TRUE BLUE" STACKERS!



Clark Equipment Australia Limited. 30 Salisbury Road, P.O. Box 50, Hornsby N.S.W. Ph: (008) 02 8537, Fax: (02) 476 2241
CONTACT YOUR NEAREST DEALER TODAY...

SYDNEY (02) 648 3777
 NEWCASTLE (049) 69 3999
 WOLLONGONG (042) 72 1811

MELBOURNE (03) 555 4499
 BRISBANE (07) 277 3233
 TOWNSVILLE (077) 79 5377

LAUNCESTON (003) 26 4211
 HOBART (002) 72 3822
 ADELAIDE (08) 243 0788

PERTH (09) 451 7966
 DARWIN (089) 81 8000
 AUCKLAND N.Z. 274 4972

Adaware

Makita BREAKERS & ROTARY HAMMERS

ALL DESIGNED AND ENGINEERED FOR LOW COST MAINTENANCE AND SERVICING



DEMOLITION HAMMER

Model HM1200K

The lightest, easiest handling and smallest demolition hammer in its class. Features anti vibration handles and forward flowing cooling system for operator safety and comfort. No more sand and dust in the face. Front grip swings 360° for easy handling. Comes with side grip. **BONUS bull point**, hex wrenches and steel carry case.

■ Powerful 940W motor ■ Blows per minute 2000 ■ Weighs only 9.1 kg.

DEMOLITION HAMMER

Model HM1300

Best in its class for speed, impact and low weight. Delivers tough scaling, digging and tamping. Just the hammer for convenient concrete and rock breaking without the hassles of compressors and hoses. Comes complete with one **BONUS bull point**, 2 hex wrenches and steel carry case.

■ Powerful 1240W motor ■ 1200 blows per minute ■ Weighs only 16 kg.

POWER SCRAPER

Model HK1810

Now you can clean out old mortars, remove wall and floor tiles, concrete slurry or weld splatter in no time at all. Features variable speed to match your material. Lightweight and fatigue free design weighing only 3.2 kg. Great for renovating bathrooms and pools etc. Comes complete with scaling chisel, bull point, hex wrench and steel carry case.

■ Powerful 505W motor ■ 0-3200 blows per minute ■ Weighs only 3.2 kg.



ROTARY HAMMER

Model HR1820 (18mm)

This light weight, heavy duty hammer features variable speed. Makes light work of overhead drilling jobs. Just the tool for setting anchors and all kinds of plugs. Accepts Hilti (TE12) and Bosch (SDS) tungsten carbide bits. Perfect for drilling into tile, brick, block or other easily breakable materials. Comes complete with T.C.T. Bit - 14.5 mm, Blowout bulb, dust collector, Bit grease, Hex wrench, depth gauge and steel carrying case.

■ Powerful 505W motor
■ 0-3500 Blows per min ■ Bit diameter 6.5 mm to 18 mm
■ Weighs only 3.1 kg ■ No load speed 1000 RPM.

ROTARY HAMMER

Model HR2510 (25mm)

This new mid-range heavy duty hammer features variable speed and takes a 25 mm bit, yet weighs only 4.2 kg. Change from percussion and rotation, to rotation with just the flick of a switch. With optional drill adaptor and chuck, makes light work of drilling with wood and metal. Accepts TE12 and SDS type T.C.T. bits. Comes complete with T.C.T. bit 14.5 mm, blow out bulb, dust collector, bit grease, Hex wrench, depth gauge and steel carrying case.

■ Powerful 620W motor
■ 0-3000 Blows per min ■ Bit diameter 6.5 mm to 25.5 mm
■ Weighs only 4.2 kg ■ No load speed 800 RPM.

ROTARY HAMMER

Model HR3850K (38mm)

Because of its heavy duty features, this is the professionals favourite. Out-powers the rest of the 900W field with a gutsy 940W motor. Features grease packed lube system giving up to 150 hours of service free operation. Accepts hex shank and kango type bits. Automatic safety clutch for operator safety. Comes complete with depth rod, hex wrench, blow-out bulb and steel carry case. **BONUS Adaptor, Sleeve and Drill Bit included.**

■ Powerful 940W motor ■ No load speed 240 RPM ■ Blows per minute 2,900 ■ Maximum bit diameter 38 mm ■ Minimum bit diameter 10 mm ■ Maximum core bit diameter 118 mm
■ Minimum core bit diameter 25 mm ■ Weighs only 7.5 kg.

ROTARY HAMMER

Model HR5000K (50mm)

Super power ... compact size. Heavy weight T.C.T. bit drilling up to 50mm. Just the tool for heavy side and overhead work. This top of the range hammer gives fatigue free use and weighs only 9.7kg and accepts other hex shank and kango type tooling. Comes complete with hex wrenches, blow-out bulb and steel carry case. **BONUS Adaptor, Sleeve and Drill Bit included.**

■ Powerful 1200W motor ■ No load speed 260 RPM ■ Blows per minute 2,100 ■ Capacities: Tungsten carbide bit 50mm, Core bit concrete 150mm, Hume pipe 255mm.

Makita

More Power Tool For Your Money

“You can bet your life on the reliability of Kawasaki Generators – I sure do”

Lieutenant Thompson
Narre Warren North Fire Brigade

“When we’re at motor vehicle accidents, bushfires and structure fires, we need all the power we can get. That’s why we use Kawasaki Generators – you can trust them to go on churning out the power anywhere, and never fail us.”



The rugged steel frame surrounding this generator protects it from accidental damage as well as making it easier to carry. That’s the design sense that goes into making all Kawasaki generators reliable power, anywhere, anytime.

That’s what Lieutenant Rhett Thompson of the Country Fire Authority of Victoria, had to say about their squad’s Kawasaki GA3200A generator. It features a powerful 7.5hp engine with low oil alert, AC/DC outlets and built-in circuit breakers. With 10 models in the range (from 550 to a mighty 4,500 watts max at 60 Hz), there’s a Kawasaki Generator to suite your size and power needs exactly.

Kawasaki

The Power behind the pros



When it comes to construction work, small thinking can make a big difference to your efficiency.

To start with there's the new generation IHI 'G' series Mini Excavator, winner of the 1988 Nikkei Shinbun 'Excellent Product' Award in Japan. It's small enough to get you into, and out of, some pretty tight spots, yet tough enough to handle some pretty heavy work.

Add to that a comprehensive range of US manufactured STANLEY mounted and hand held hydraulic breakers, tampers, drills, saws, pumps and other tools and you've got a complete construction system that's about as small as the cast of Ben Hur.

Call us for some small talk today – it will pay dividends on your next job.

MOLE
GROUP OF COMPANIES
THE *W*HOLE SOLUTION

SYDNEY: (02) 688 8011 • MELBOURNE: (03) 305 4191
BRISBANE: (07) 277 5744 • NTH QUEENSLAND: (077) 79 8688
PERTH: (09) 350 5410 • ADELAIDE: (08) 276 8166
HOBART: (002) 34 6258 • KALGOORLIE: (090) 21 3000
DARWIN: UNIVERSAL DIESELS – (089) 81 3852

LET'S
MAKE
SMALL
TALK

Airline's new use for containers

A fleet of hired storage containers has helped Australia's national carrier, QANTAS, carry out a major aircraft refurbishing program.

The job, which was catered for by Container Rentals, a division of Prestige Portables, demonstrated once again the versatility of these simple but effective "strong boxes." Container Rentals provided QANTAS with 21 containers over a period of six months beginning in October last year.

QANTAS wanted to upgrade the chairs and other furnishings in the business and first-class sections of 16 jets.

The company elected to send the new furnishings from Sydney to Melbourne where a firm had been engaged to carry out the work.

After looking at various options for transporting and storing the bulky materials, QANTAS chose containers because they could be easily handled and stored securely outdoors. Six containers were able to accommodate the replacement chairs and other furnishings for each of the large aircraft. They were trucked to Melbourne and stored outdoors until their contents were needed. Being secure and weather-proof, the storage situation presented no danger. The containers were then filled with the old chairs and furnishings, and trucked back to Sydney.

QANTAS' supply projects controller, Geoffrey Pollard, said Container Rentals had provided first-class service.

"We were not sure at the outset how many containers we would need, so we started with a few and built up," Mr Pollard said.

"I would give them 48 hours notice, and they always made the deadline, and bent over backwards to give good service."

Container Rentals, which has branches in Sydney, Newcastle and Brisbane, says containers provide a perfect answer to short or long-term storage needs over a wide range of applications.

Each unit provides 26 cubic metres of safe, lockable, weather-proof storage, enough to hold 20 tonnes, and deep enough for storage of six-metre long material through the provision of a "plumber's boot" or racks.

Thirty or more units provide storage capacity equal to that of a medium-sized warehouse.

Being portable, they can be moved around easily, manoeuvred into corners, or stacked on top of each other to save space. Access is another plus - they are big enough to get a forklift in and out.

The versatility of container storage is demonstrated by other jobs catered for by Container Rentals.

Motor cycle company, Honda, hired 21 containers to store spare parts at its Rydalmere distribution centre.

The Cruising Yacht Club at Rushcutters Bay in Sydney hires containers to store the belongings of yachtsmen who sail in the annual Sydney to Hobart Race.

Stationers, Esselte Dymo, rented more than 30 containers when they stepped up production in anticipation of moving to a larger plant - and the move was delayed.

Seiko watches, Speedo swimwear and Grace Bros are among other major companies which have made use of this simple but effective form of storage.

The managing director of Prestige Portables, Gordon Esden, said his company had pioneered the hiring of containers for storage in the early 1980s.

"Building construction sites needed a better security storage system," he said.

"We began buying containers which were redundant to the needs of the shipping industry, removing the rust, and restoring them."

"The usage gradually spread into many diverse areas, including factories and warehouses and onto the retail front, such as in service stations, liquor outlets and hardware shops."

Container Rentals, 15 Rowood Road, Prospect. 2149.
Ph: (02) 688 2688, or, toll free (008) 26 7979.

DON'T LEAVE THE GROUND WITHOUT ONE.

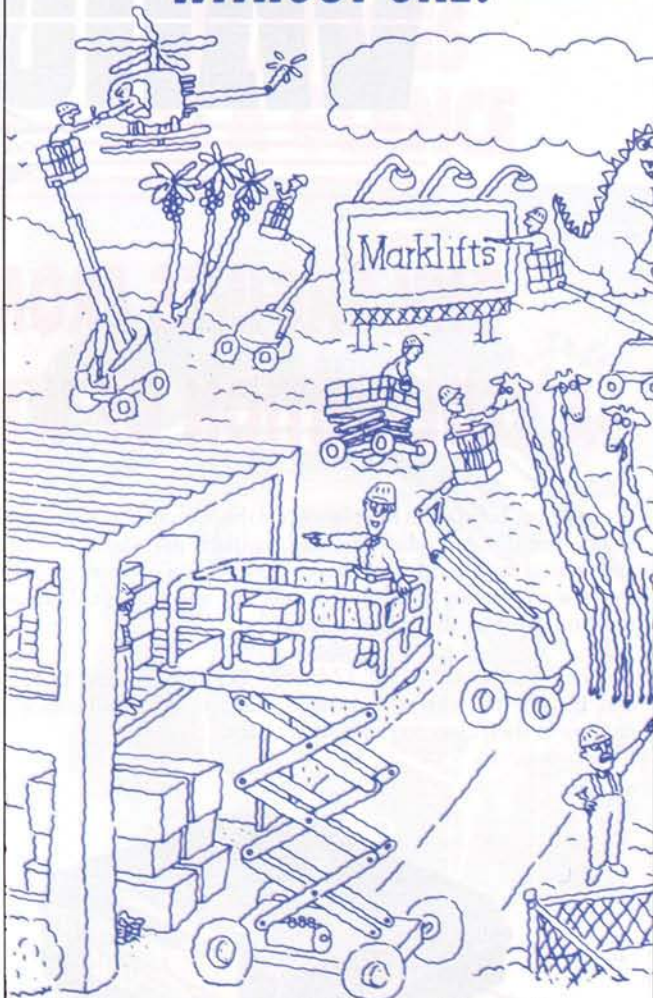

Whether you're 10 ft. up or 100, you'll be glad you're in one of our Marklifts.

Before these rugged booms, knucklebooms and scissor lifts leave the factory, they must undergo over 300 tests and inspections. With slope warning devices, automatic power shut off systems, travelling or extendable decks on scissors, zero tail swing, internal retraction systems, and 360° turret rotation on booms, leaving the ground has never been safer or easier.

As the sole authorised Marklift distributor in Australia we can show you how dozens of hire fleets have benefited from our products and our product support.

We look forward to seeing you in Adelaide.

M.I. (Australia) Pty. Limited

Lot 11 Plasser Crescent

ST. MARYS N.S.W. 2760

Phone: (02) 833 1909 Fax: (02) 833 1904

The Marklifts.

A Product of Mark Industries. U.S.A.

VANGUARD

BRIGGS & STRATTON

OHV ENGINES FROM BRIGGS & STRATTON -A REDEFINITION OF WHAT AN ENGINE SHOULD BE

We at Briggs & Stratton have launched the Vanguard range of OHV engines onto the Australasian market. Available in a range of horizontal and vertical shaft designs, including a series of V-Twin configurations, the new engines are quite unique in design and concept. They are a redefinition of what an engine should be.

The new Vanguard 5.0, 9.0, 12.5 and 14.0HP singles and 12.5, 14.0 and 16.0HP V-Twins will out-start, out-run and out-distance any engines in their class on the market today.

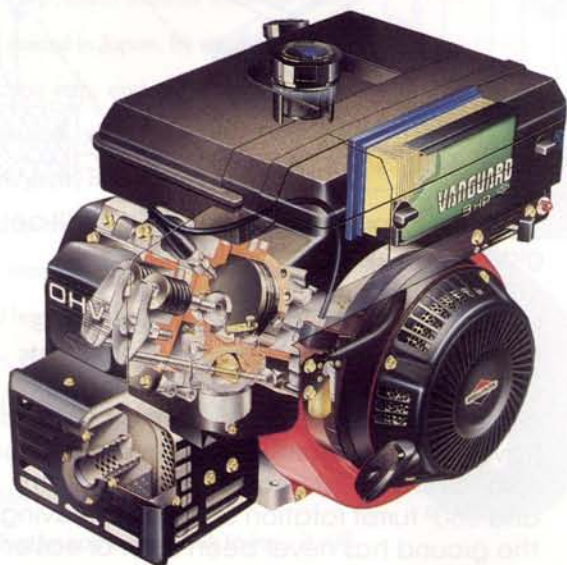

The OHV V-Twin engines with 90 degree configuration provide smooth running with minimal vibration. The overhead valve design ensures cool running with long valve life and clean combustion and minimal carbon accumulation.

Incorporating a pressure lubrication system with spin-on oil filter (not applicable to 9HP model) which not only keeps the oil clean but extends the time between oil changes, the new Vanguards feature ease of service.

The Vanguard range has been exhaustively tested in the field and on the workbench. The range is backed by a two year engine warranty and a five year warranty on the Magnetron[®] electronic ignition system.

Vanguard engines can be supplied with integral fuel tanks or fitted with fuel lift pumps. A cast iron cylinder sleeve ensures excellent resistance to wear while at the same time improving oil control.

A dual element air cleaner fitted with pleated paper automotive type cartridges with foam pre cleaners ensure superior protection and greatly extended engine life.

All horizontal shaft Vanguard models are fitted with replaceable ball bearings on the PTO side and replaceable sleeve bearings on the magneto side.

The Vanguard engines have exceptionally quiet running characteristics thanks to a most effective sound treatment package which incorporates a laminated polycore blower housing, phase-modulated flywheel fins, an acoustically contoured crankcase, elliptical and tapered piston skirt and a low tone muffler.

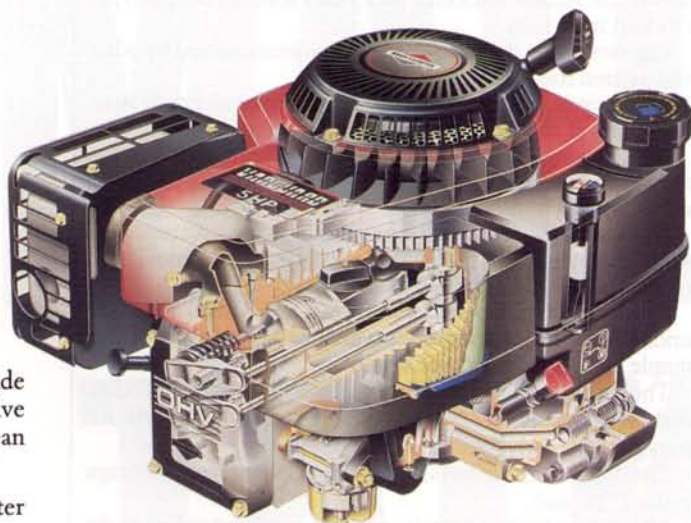

OHV DESIGN

Overhead valve design gives cool running with long valve life and clean combustion with minimal carbon accumulation.

SOME VANGUARD FEATURES AT A GLANCE

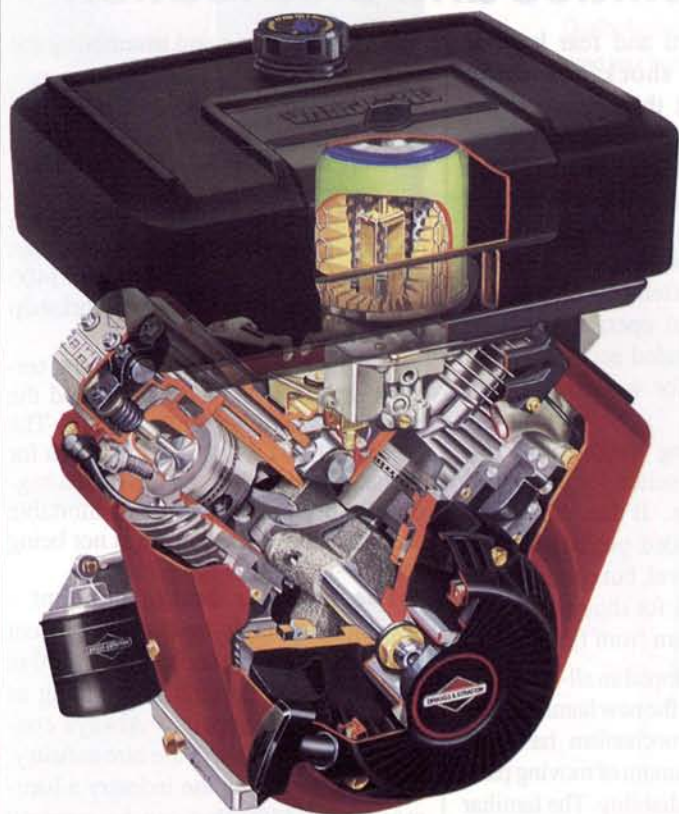

OHV V-TWIN ENGINE

With 90 degree configuration, provides smooth running with minimal vibration in a convenient compact package.

FUEL PUMP

Engines can be supplied with fuel lift pump or with integral fuel tanks.



**MAGNETRON®
ELECTRONIC IGNITION**
Dependable spark for consistent sure starts. Will never need maintenance or adjustment.

CAST IRON CYLINDER SLEEVE

Ensures excellent resistance to wear with improved oil control.



VANGUARD

BRIGGS & STRATTON

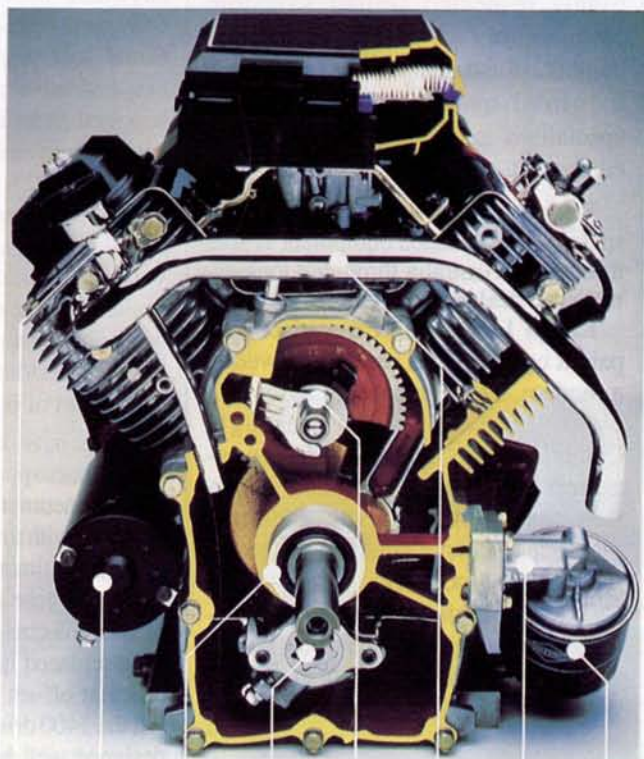

⑧ ① ② ③ ⑦ ⑥ ⑤ ④

1. STARTING

Engines are available with electric start, manual rewind start or a combination of both.

2. BEARINGS

All horizontal shaft models have replaceable ball bearings on the PTO side and replaceable sleeve bearings on the magneto side.

3. FULL PRESSURE LUBRICATION SYSTEM

Oil pump provides pressure fed controlled flow of oil to bearings for wear resistance. (Not applicable to 9.0HP horizontal shaft model.)

4. FULL FLOW SPIN ON OIL FILTER

Keeps oil clean and extends time between oil changes. Easy to service. Remote oil filter adaptors are available for confined installations. (Not applicable to 9.0HP horizontal shaft model.)

5. LOW OIL WARNING

A sensor is available with pressure lubricated models. The 9.0HP horizontal shaft model can be fitted with Oil Guard®.

6. EXHAUST

Various manifold/muffler combinations are available.

7. GOVERNOR

Mechanical Governor provides rapid, precise control of engine speed.

8. EXTENDED DIP STICK & OIL FILL

Convenient checking of oil level and refilling of oil is facilitated by extended dip stick and oil fill tube.

Kango invests in new facilities and distribution

Kango Australia Pty Ltd with the headquarters of their South Pacific operation in Chipping Norton (south-west metropolitan Sydney), NSW, are a subsidiary company of Kango Ltd, the long established and highly respected United Kingdom manufacturer of electro-pneumatic demolition and rotary drilling hammers, industrial quality power tools and specialised automotive engine repair equipment.

Kango power tools, accessories, spares and associated equipment is sold throughout Australia through a long established dealer network.

Kango Ltd, the UK manufacturing parent company has recently moved to a modern, well equipped and more efficient site at Peterborough, Cambridgeshire. Many new design engineers are already making their important contributions to the updating, modification and evaluation of the entire electrical tool range.

The first evidence of this new commitment to new designs and product development is evident with the advent of the new model 1400 demolition hammer.

This brand new high performance hammer from Kango has been designed for heavy demolition and breaking without losing the versatility that has become the main feature of all Kango machines.

Ease of use and operator comfort were the initial parameters established by Kango's Australian team when the concept of the 1400 was being

developed. Forward and rear handles are mounted in shock absorbing material to protect the operator from both high and low frequency vibration. The front handle can be rotated through 360 degrees and the grip can be locked anywhere between fully forward and fully back to suit the operator. An additional soft grip extension handle for two-handed vertical operation will be supplied as an included accessory. It is easily removable for working in confined spaces.

With an operating weight of 14kgs, the 1400 is ideally suited for prolonged vertical operation. It has not been designed for extended periods of wall work above knee level, but certainly can be used horizontally for short periods up to a height of 600mm from floor level.

Kango have developed an all-new 1400 watt motor to power the new hammer. The electro-pneumatic mechanism has been designed with a minimum of moving parts to ensure ultimate reliability. The familiar crank disc gear and con rod configuration of most electro-pneumatic hammers has been replaced in the 1400 with the more efficient off-set transducer drive system. All the 1400 drive components have been designed well beyond the normal limits found in most hammers of this specification. The philosophy behind this overall "beefing up" is Kango's appreciation of the rugged treatment that equipment is subjected to in the hire industry.

When a scheduled service is required, Kango's design engineers have also made major advances in this field as well. No special service tools are essen-

tial for dismantling and assembling the 1400.

A selection of inexpensive, but effective Model 1400 service tools have been developed by Kango for workshops that will be servicing large numbers of hammers. These tools have been designed to reduce the time factor in servicing, but efficient and accurate work on the 1400 can be achieved with standard workshop tools.

All electrical connections are terminated on spade terminals behind the bottom cover of the motor module. The switch is fitted with a "lock-on" pin for prolonged operation and the switch trigger has been extended for comfortable use when the "lock on" pin is not being used.

The modular design concept - developed strongly by Kango in recent years - has been extended in the 1400 in order to speed up regular servicing as well as general repairs. Always conscious of down time in the hire industry, Kango are offering the industry a hammer in the 1400 that can be serviced regularly, so extending earning capacity and reducing maintenance costs.

A special tool "catcher" mechanism has been incorporated in the transmitter housing to prevent the continuation of the hammer action when the tool is removed from the work surface. A quick change latch system ensures that tools can be changed quickly and easily.

All Kango 900 series, 950 series and 1100 series tools and accessories can be used with the 1400. This will be a major benefit to all Kango hire company clients with large stockholding of Kango tooling.

GKN light access polecat

GKN Light Access has expanded its range of rental equipment with the addition of the Polecat, a highly mobile one-man electric work platform. Its 3 metre platform height provides an effective reach of 4.8 metres, allowing it to tackle any task where overhead reach is a problem.

There's a multitude of applications in the factory environment. Working on sprinkler or lighting systems, installing insulation, removing asbestos, stocktaking or in cleaning and maintenance

projects the Polecat offers significant productivity advantages.

The Polecat is the smallest of GKN Light Access's self-powered work platforms. It can pass through standard doorways and is light enough to travel in elevators, so it can be moved easily inside buildings to reach different floors or confined locations.

Electrical operation makes the Polecat extremely quiet and its light weight and soft rubber tyres mean it won't damage carpet or other sensitive floor surfaces.

All controls can be operated from the extended position, so the Polecat virtually makes the user five metres tall.

The Polecat is available from GKN Light Access branches around Australia and can be rented for as little as a single day. Full instructions on operation and safety are given, and the machine is delivered to the workplace.

For further information contact:

Robert Damiani - Branch Manager
51 Hill Road, Lidcombe NSW 2141
Tel: (02) 748 3434

Quality Australian made products
making your business look better.

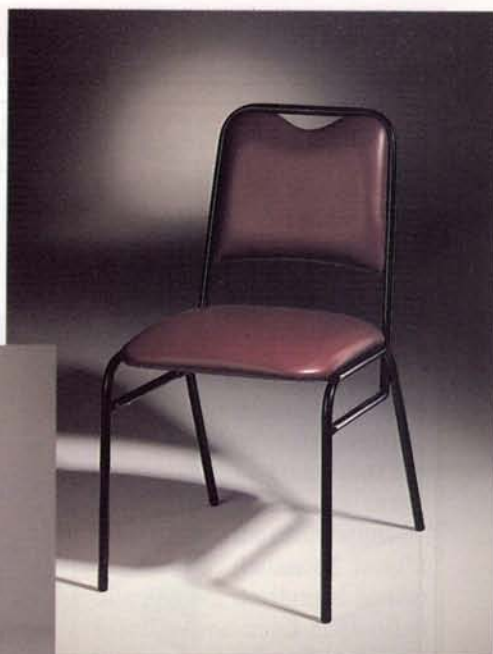

Designed for the Hire & Rental Industry, Namco Furniture offers stacking and non-stacking chairs for indoor and outdoor use in a variety of colours and finishes. Co-ordinated with a wide range of folding and non-folding tables, Namco can cater for all your furniture needs.

Manufactured by

NAMCO FURNITURE
A Division of Email Furniture Limited

TOLL FREE
Tel: (008) 112 474

BRISBANE
45 South Pine Road, Strathpine
PO Box 71, Strathpine
Queensland 4500
Tel: (07) 205 2222
Telex: AA41372
Fax: (07) 205 1296

GOLD COAST
Unit 7, Upton Square,
25 Upton Street, Bundall,
Queensland 4217
Tel: (075) 92 3739

TOWNSVILLE
Hyde Park Centre,
Woolcock Street,
Townsville, Queensland 4810
Tel: (077) 21 1636
Fax: (077) 21 1765

SYDNEY
OFFICE:
3 Box Road, Caringbah
PO Box 270, Caringbah,
New South Wales 2229
Tel: (02) 540 2244
Fax: (02) 525 1980

SHOWROOM:
741 Botany Road,
Rosebery, N.S.W. 2081
Tel: (02) 318 2744

CANBERRA
5 Lyell Street,
Fyshwick,
A.C.T. 2609
Tel: (06) 280 6643
Fax: (06) 280 7436

MELBOURNE
152 Burwood Road, Hawthorn,
Victoria 3122
Tel: (03) 819 4200
Fax: (03) 819 6597

Namco reserves the right to make technical improvements without prior notification.

namco
FURNITURE

NF 956/6/90

HIRE and RENTAL - JULY 1990 - 33

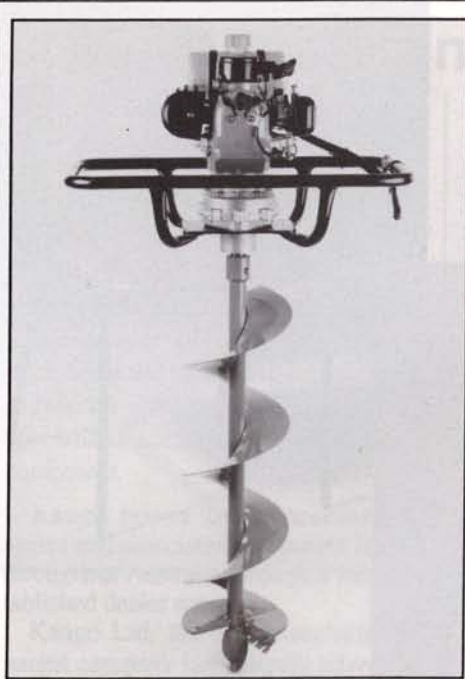

The Tanaka JEA-50 auger from Parklands Trading Co. Pty. Ltd.

New Tanaka earth auger released by Parklands

Parklands Trading Co. have just released the Tanaka JEA-50 earth auger. Improving on standards set by the first Tanaka auger released in 1965, the new machine features a much more powerful two stroke engine - with a 35% increase in capacity.

Ideal for fencing contractors, farmers and government authorities, the JEA-50 features a 33:1 reduction gearbox for improved productivity. Shaft speed is 180 rpm. The shaft is controlled by a low engagement centrifugal clutch. This allows the operator to dig comfortably at lower rpm. With lower revolutions the operator can expect a longer productive life.

The JEA-50 also features a large rectangular handle for safe, easy operation. Standard handles can be used by one or two people - for the 8" (200 mm) auger. A set of two person extension handles are available as an option, for use with larger augers of up to 12" (300 mm)

The grease packed gearbox is designed for ease of maintenance. The isolated clutch housing prevents any obstructions from damaging the gear box. According to Mr. Ron Zacka, Parklands' Sales Director, "Designed for efficient and reliable operation, the JEA-50 earth auger is made in the Tanaka tradition of using only the best materials". Providing the user many years of service, our new machine is the best value for money auger available in Australia."

For further information, please contact:
 Mr. Ron Zacka
 Parklands Trading Co Pty. Ltd.
 71 Chapel Street
 Lakemba, N.S.W. 2195
 Phone: (02) 758 2111, Fax: (02) 759 7844

A lift at the right price

Whatever your application... if you need to get above the crowd, Instant Scaffolds has a self-propelled Scissor or Vertical Personnel lift to suit your budget and your application. There's a comprehensive range from which to select featuring low cost, high quality, proven reliability and professional support -

all from...

INSTANT SCAFFOLDS.

Take your pick from **INSTANT ZIP-UP**

Outstanding features:

Vertical Lifts

- * The choice for wall & corner applications.
- * Work in complete safety at heights of up to 13.3 m.
- * One man operation including loading and unloading of a vehicle.
- * Power outlet is conveniently located on platform.
- * Approved by the Dept of Industrial Relations & Employment.

Scissor Lifts

- * The tightest turning circle in its class!
 - * Forward and reverse controls.
 - * Compact design lets you drive through standard doorways and yet you can work safely to heights of 9.7m.
- Both models are:**
- * Competitively priced.
 - * Quality backed 12 month warranty . 24 hour servicing available.

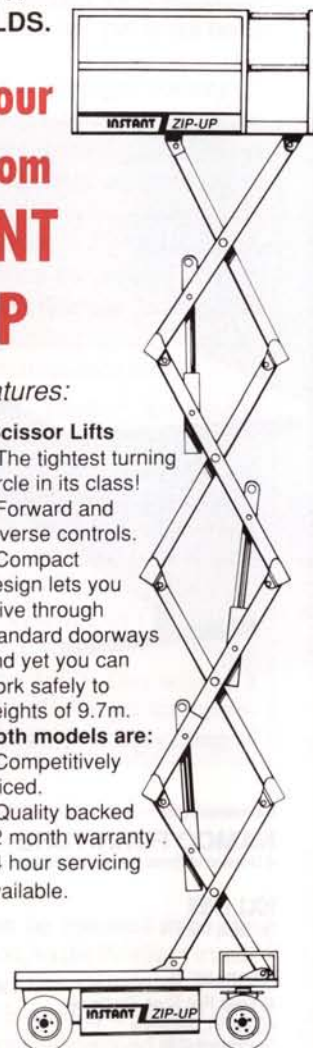
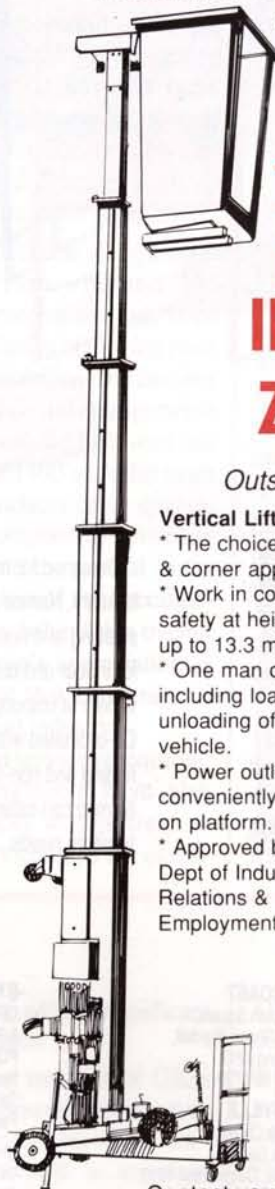

Contact your local office for all the details.

INSTANT SCAFFOLDS

An all Australian company

Artarmon Ph: (02) 439 6200

Bankstown	Ph: (02) 708 6422	Hobart	Ph: (022) 343 747
Girraween	Ph: (02) 636 6600	Adelaide	Ph: (08) 234 1200
Newcastle	Ph: (049) 69 4133	Perth	Ph: (09) 481 2060
Wollongong	Ph: (042) 263 429	Brisbane	Ph: (07) 846 2999
Clayton	Ph: (03) 543 5566	Gold Coast	Ph: (075) 346 066
Coburg	Ph: (03) 350 4199	Cairns	Ph: (070) 331 400

Partner power saws back with a vengeance!

Contrary to popular competitor belief (and hopes) PARTNER POWER SAWS in Australia are here to stay.

PARTNER INDUSTRIAL PRODUCTS of Sweden and DEMBICON AUSTRALIA have re-negotiated their agreement, with DEMBICON now taking complete control of the entire PARTNER power saw product range, including all accessories and spare parts, being imported into Australia.

Effective immediately, all PARTNER power saws, accessories and spare parts for current models are readily available anywhere in Australia. This is coupled with an improved local service support for prompt repairs and product maintenance. At last we can now meet your needs more efficiently and quickly.

But the best news is yet to come, the most beneficial gain to Australian customers will be a more competitive price structure for power saws and an expanded product range to suit all hand-held tool sawing needs.

Being the inventors of power saws the PARTNER range is by far the most technologically advanced and comprehensive on the world market today.

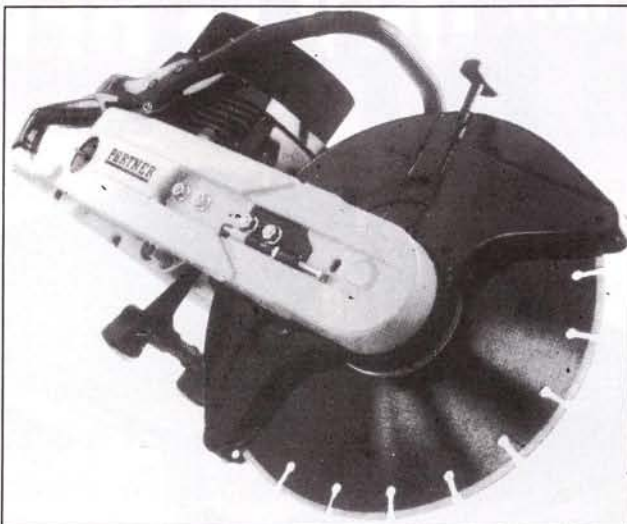

Partner Power saw K700.

Developing the right product for the right market is what PARTNER does best.

DEMBICON AUSTRALIA proudly unveils the latest design in hand-held sawing technology with the new K700.

This compact 14" blade capacity saw is the ideal 'partner' for tradesmen, pavers, contractors, councils and in particular hire companies requiring a lightweight (21.8 lbs/9.9 kg) but powerful machine capable of giving a deeper cutting depth, up to 5 inches /130 mm, all in the same model.

This remarkable machine is already

highly popular with hire companies and contractors throughout Europe and the USA.

Ideal for cutting steel, asphalt, stone and concrete the K700 has a unique power/weight ratio undoubtedly placing it in a class of its own. The research tests completed by PARTNER in Sweden prove this fact, see the chart below.

Featuring balanced weight distribution, devibrated handle system, one-hand controlled blade guard, reversible cutting arm, a 5 stage air filter system and more the K700 will cut your costs - everything you would expect from the world's most

advanced range of power SAWS. Many of these listed features are also standard with the existing PARTNER range.

All PARTNER power saws feature ergonomic design making it easier when sawing vertically for long periods of time. We have not adopted chain saw technology design for power cutting application. Instead the PARTNER range is purposely designed for its application.

In addition, PARTNER is the only brand to offer power saws powered by petrol, hydraulics, pneumatics or electricity. We also have the widest range of saws - 7 in total, including the world's only standard 16" blade guard facility unit which can be fitted to a SUPER CARRIER for continuous flat horizontal cutting.

Naturally, DEMBICON diamond blades are recommended as the logical 'partner' to this exciting range of hand-held power saws.

For more specific information on the K700 or the entire PARTNER range of saws please contact DEMBICON direct on 008 888 343 and ask for Philip Rowden.

PARTNER - the brand by which all other power saws are measured.

Power / Weight Ratio Partner Industrial Products

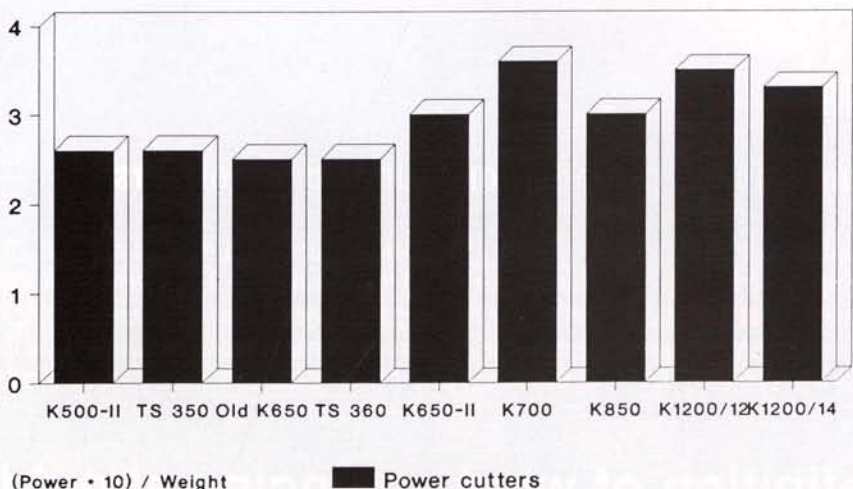

VANGUARD

9 H.P. OHV IS HERE!

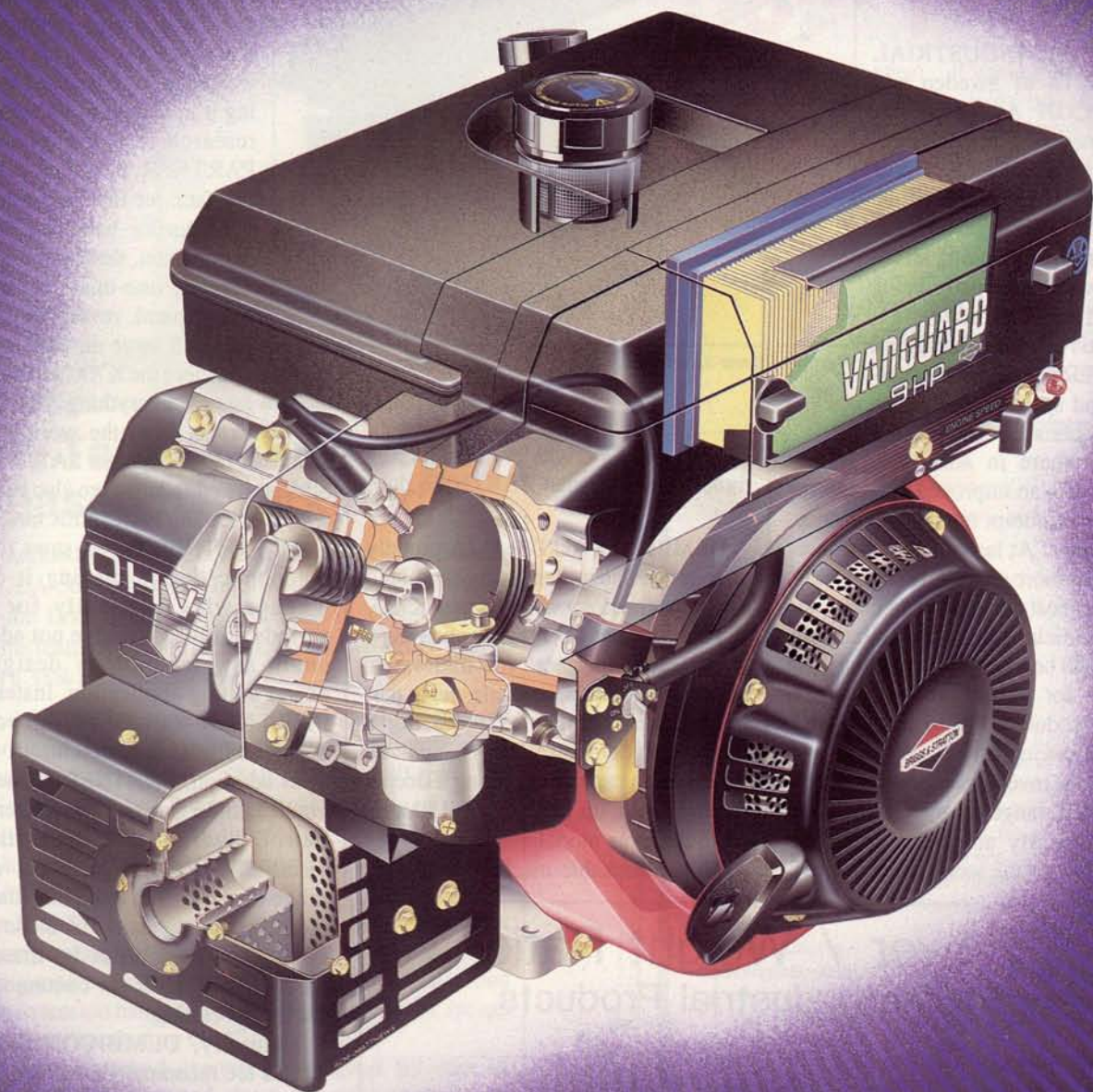

The first in a new generation of powerful long running performers.

■ Overhead valve design delivers cleaner combustion, with minimal carbon deposits and fewer tune-ups. ■ Designed as a true 2000 hour engine. ■ 16.5 cubic inch displacement (270 cc) highest in its class. ■ More torque - 12.9 ft. lb. peaking at 2,800 rpm. ■ Rotating counterbalance shaft virtually eliminates engine vibration. ■ Laminated steel blower housing and large capacity muffler; reducing noise emission to an absolute minimum. ■ Oversized, front mounted, dual element Air Cleaner - no tools needed for servicing. ■ Oil Guard optional. ■ Magneton electronic ignition. ■ Cast iron cylinder sleeve. ■ Supported by the finest parts and service network in the world.

VANGUARD
EQUIPMENT & SUPPLY

- a redefinition of what an engine should be.

YOU CAN FEEL THE EARTH MOVE

The CASE VIBROMAX 1102 not only compacts the hard core foundation but also sets up a two stage vibration process that enables the earth to settle into a far more compact and stable situation.

2 STAGE VIBRATION	STAGE 1	STAGE 2
CENTRIFUGAL FORCE	172kN	105kN
FREQUENCY	28Hz	36Hz
NORMAL APTITUDE	1.6mm	0.6mm

(Figures quoted are for smooth drum configuration.)

This combination of vibration and compaction beds down a far superior foundation for roads that will last longer under heavy traffic conditions.

The Case Vibromax is an 11 tonne self-propelled roller with full hydrostatic propulsion and vibration drive, has hydrostatically operated articulated steering and smooth or pad-foot interchangeable drums.

Call Head Office or your local dealer NOW on the numbers listed below for more information on the complete range of CASE

**VIBROMAX
ROLLERS.**



case VIBROMAX

CASE VIBROMAX AUSTRALIA PTY LTD

CASE VIBROMAX 1102 • SMOOTHING OUT THE MILES

Kurrajong Avenue, St Marys, N.S.W. 2760 TEL: (02) 673 7777 FAX: (02) 833 1128

QUEENSLAND (07) 375 4181. VICTORIA (03) 359 3911. SOUTH AUSTRALIA (08) 459 800.

TASMANIA (002) 72 5666. NEWCASTLE (049) 54 7066. WESTERN AUSTRALIA (09) 277 4777.

The Silver Partnership CASE 0679

HIRE and RENTAL - JULY 1990 - 37

New South Wales Report

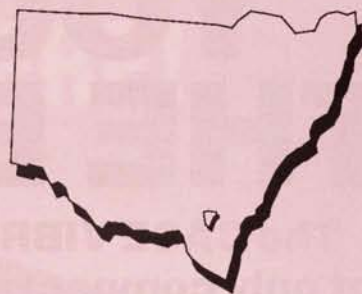

Committee Meeting - Forster - 16/17th July '90

An "away" Committee Meeting will be held at the Island Palms Motor Inn, 115 The Lakesway, Forster on Monday, 16th July. Accommodation will be available for those who require it. This is a great opportunity for Country Members to meet up with the City members and attend an Association Committee Meeting.

The second Party Hire Meeting will also be held on this date in Forster. Our President, Bruce Fraser will be on hand to Chair the Meeting. Make the most of this opportunity and attend.

Requirements of act in regard to hiring of explosive power tools

We have been advised by WorkCover Authority that it is an offence under the Construction Safety Act to hire any explosive power tools (e.g. Ramset Gun) to any person who is not the holder of an appropriate certificate of competency, as an Explosive Powered Tool Operator.

Any person not holding a certificate who plans to use an explosive powered tool can obtain a certificate by satisfactorily passing a one day course available from the manufacturers, Ramset Fasteners (Aust) Pty Ltd. Ph: 748 4488, or Hilti (Aust) Pty. Ltd. Ph: 648 4466.

If you are in the position to hire any such explosive power tools, please make sure the person hiring them has such a certificate., otherwise you can also be held guilty of an offence under the Act.

Workshop - "Ramset" - 22/08/90

As a result of our inquiry to the NSW WorkCover Authority regarding Hire Companies obligations when hiring out Ramset Guns, we have decided to hold a

Workshop covering the use and maintenance of explosive tools. Ramset Fasteners have kindly agreed to host this night. For further details phone Chris Stewart on 634 2964.

Training Seminar - 6/7th August '90

The fourth in our series of training Workshops will be conducted by Ron Mobbs, B. Comm.

The topic of this Workshop is "Problem Solving & Decision Making". Problem solving involves identifying that a problem exists. Decision making involves selecting one solution from a number of chosen alternatives. Structured activities, case discussion and self-testing instruments are used to achieve an interactive approach to this issue.

Mark these dates in your diary now!!

Instruction Sheets

The NSW Branch has produced a set of Instruction Sheets together with an A4 Binder at a cost of \$120 per set. Orders are being taken now, so if you wish to order one please phone Chris Stewart on 634 2964.

These Instruction Sheets will be printed on white glossy paper suitable for Companies to phototcopy. Additional sheets will be added to the set periodically.

D.I.R. electrical requirements for construction sites

There appears to be largely varying procedures being accepted by the Unions on sites in relation to the above Requirements, which is in contradiction to the agreement we had with the D.I.R.

Because of this, the Association has sought an urgent Meeting with the D.I.R.

to discuss the problems being encountered by our members on sites, and to seek their endorsement of the Agreement made in July, 1988. This agreement says categorically that there is no need for a licenced electrician, but instead a responsible person employed by the Hire Company; when using a proprietary testing device. As to the tagging of equipment and the colour-coding which the unions are trying to enforce, the DIR have no stipulation, at present, for this. The Association is at present seeking discussion with TAFE to conduct a short course on Electrical Appliance Testing, similar to what has been conducted in Victoria. This short course has been accepted in Victoria by the D.I.R. and therefore the Unions have been forced to accept it.

Colour-coded tags

The Association is at the present time negotiating with the manufacturer of these colour-coded tags in an endeavour to buy in bulk at a cheaper rate and then supply members. You will be kept informed.

Association library

Don't forget that we have Paul Dunn's Video entitled "PHONE RIGHT" available for hire to members at a cost of \$50. If you wish to use this as an instructional video for your employees, give me a ring!

We also have John Lees (who was a speaker at our Principal's Seminar in February) audio cassette tapes entitled "Sold on Selling", which are available at a cost of \$20.

Labels for machinery

We have new supplies of these very popular "stickers" available shortly, If you would like to order some please complete the order form attached to this Newsletter.

DOSKO

The Fast Easy To Use, Portable One Man Stump Grinders

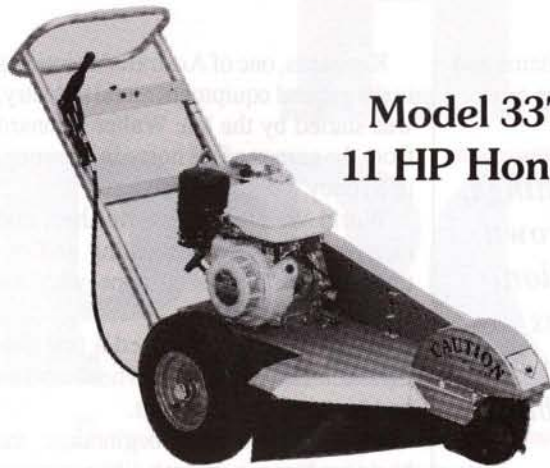

Model 337
11 HP Honda



Model 782
20 HP Onan
(Self Propelled)

PATENTED

- 2 1/2 Year Frame and Handle Bar Warranty
- Specially Designed Cutter Wheel uses only 8 teeth. Cuts faster and with less physical effort than machines with 12 or 18 teeth. Cuts tooth and labor cost in half.
- Front Mounted Cutter Wheel for Operator Safety.
- Optional Engines 10 to 12 HP Recoil Start - Kohler, Wisconsin, Honda or Briggs & Stratton
- Optional Engines 18 to 20 HP Electric Start - Kohler & Onan

TREE Root Cutters



Dosko
Model RC14SP
(Self Propelled)

PATENT PENDING

*Disc Trenchers So Powerful
Their Sold As Root Cutters!*

Three Models
Available

POWER PRUNER

THE LIGHTWEIGHT GASOLINE-POWERED
PRUNING TOOL

SAFE ♦ SAFE ♦ SAFE

Cut hard-to-reach places from the ground.
Patented features eliminate kick-back danger.
Operator can stay clear of falling branches and debris.

**TELESCOPING SPLINED ALUMINIUM
DRIVE SHAFT**

Cutting height approximately 6 metres and below.

USED FOR:

Parks • Golf Courses • Campus • Cemeteries
Orchards • Rental Outlets • Personal Use

**PORTABLE — PRODUCTIVE
LOW-MAINTENANCE**

Easy To Maintain • Cleans Up Fast
Sealed Bearings • No Lubrication Necessary

LOW PRICE

A fraction of the cost of cumbersome
hydraulic or air-driven systems.



Australian Distributor . . .

C.R.C. Australia Pty. Ltd.

185 Allambie Road, Allambie Heights, N.S.W. 2100

Tel: (02) 452 3298 Fax: (02) 451 6044

College of Hire Education

Kennards Hire has broken new ground in the general equipment rental industry by setting up a special staff training centre.

The centre is appropriately named: Kennards College of Hire Education.

Managing director, Andrew Kennard, said the training centre, at Guildford in Sydney, served a dual purpose.

"New staff are trained in all aspects of the industry, from dealing with customers to the intricacies of the various types of equipment," Mr Kennard said.

"Existing staff undergo regular courses to update their knowledge on new equipment and other developments."

Mr Kennard said "on the job" training was no longer sufficient in itself.

"The industry has to keep pace with the 1990's and prepare for the 21st Century," he said.

"The range of equipment now carried by rental companies such as Kennards is

enormous, and there are new items and new models being added all the time.

*From modest beginnings,
the business has grown
into a huge operation,
with 14 branches
throughout Sydney,
Newcastle and Brisbane.*

"We want all of our people, new and old, to be on top of things so that they can provide customers with the best possible advice and service."

Mr Kennard said customer relations was a vital part of any business.

"Courtesy has always been a cornerstone of the Kennards' company and we have that drummed into staff.

"People are not going to come back if they are treated shabbily."

Kennards, one of Australia's pioneers in the general equipment rental industry, was started by the late Walter Kennard from the garage of his home in Mosman, in Sydney's northern suburbs.

World War II had just finished, and many people were renovating and extending their homes to cope with the "baby boom."

Walter Kennard obtained a few old-style cement mixers and wheelbarrows and began hiring them out.

From those modest beginnings, the business has grown into a huge operation, with 14 branches throughout Sydney, Newcastle and Brisbane.

Kennards also has interests in several other specialist hire companies, including Conveyor & Hoist Rentals, Australian Hi-Reach Rental, Prestige Portables, Easi-Stor and Hi-Climber Rentals.

The Kennards company has remained a family business, and is operated by Walter's sons, Neville and Andrew.

"MEET JUNIOR"

He's a little bent but he can go straight if you want him to

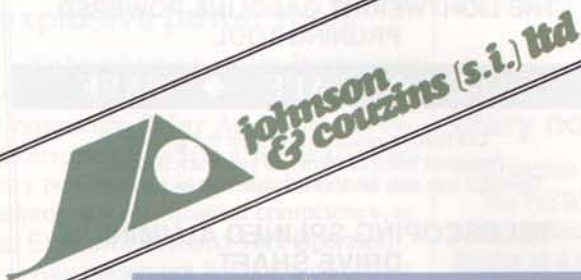

protected by Patent application No. 222-502

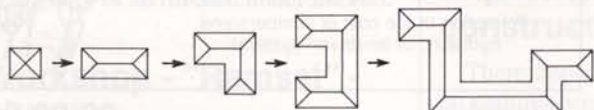

AND YOU SHOULD SEE WHAT HE CAN DO WHEN HE GROWS — ALL USING THE SAME STRONG SIMPLE FOOL-PROOF PARTS

**SUPER FRAME SERIES
MODULAR MARQUEE
SYSTEM**

Designed & Manufactured for the Australasian Rental Industry

HIRE PROFITS

There are only two colours in business, red & black, and no mini excavator can deliver rapid profits like Komatsu.

*From the smallest to the largest in the Komatsu range you can expect the same quality, reliability and ease of operation that have put many an operator out of the red and into the black. No matter how you stack it up, **Komatsu gets results** — Even your accountant would agree.*



KOMATSU

ANI KOMATSU

NSW (02) 726 8111 QLD (07) 379 6711

VIC (03) 359 3255 SA (08) 262 4116

TAS (002) 48 5414

MC KOMATSU

WA (09) 351 0555 NT (089) 84 3633

Hire Profits

A bigger "top-gun" knuckle boom from JLG



JLG's latest elevating work platform.

JLG Industries (Australia) Pty. Ltd. has introduced the largest yet, model in the company's top selling "Top-Gun" series of knuckle boom elevating work platforms.

Designated the JLG 60HA, the first machines have been delivered from the Port Macquarie (NSW) factory to Whelan Hi-Lift Rentals and Wreckair Hire in Victoria.

This new 60HA is typical of the JLG marque with heavy-duty design evident on both the upper and lower works. The

machine now comes with the well-known JLG oscillating axle and features the new Deutz 1011 diesel engine which appears to run significantly quieter than the earlier models.

The 60HA, to all intents and purposes, looks like a larger version of the now well-known 45HA series, featuring an all steel 3-stage telescoping lower boom and all steel 2-stage telescoping upper boom. The knuckle

design is simple and functional, and as with the 45HA, when the lower tower section is fully extended and the upper boom at maximum out-reach, of some 10 metres, the 60HA is remarkably smooth to operate under mobile conditions.

The machine is equipped with proportional control as standard, a usefully sized 1.5 metre long all steel work platform with 180 degree hydraulic rotation, a nicely laid out control panel and all the normal features one associates with JLG products here in Australia.

The 60HA is delivered as standard with foam filled tyres, 360 degree swing, hydraulic platform, diesel power, oscillating axles for enhanced tractive capability in difficult ground conditions, protective bellows on exposed cylinders, travel warning alarm system and amber rotating beacon. The whole package is delivered in customer livery and with JLG's now famous superior finish and attention to detail.

The 60HA is the third articulated boom to be introduced in Australia, complimenting the 45HA series and the 33HA series. The 60HA is available in reasonable supply in both 2WD and 4WD versions and like all JLG products is supported with the JLG 5+1 warranty: 5 years on all fabricated major components (which says a lot for JLG's confidence in their workmanship) and 12 months on the balance of components.

Further information is available from:
 JLG Industries (Australia) Pty. Ltd.,
 P.O. Box 972,
 Port Macquarie NSW 2444
 Telephone: (065) 81 1111
 Fax: (065) 81 0122

YANMAR

CARRIERS



Distributed by

TUTTS

LOADERS



EXCAVATORS



BRISBANE
 (07) 277 5422

SYDNEY
 (02) 684 4400

MELBOURNE
 (03) 314 0011

HOBART
 (002) 78 1211

ADELAIDE
 (08) 262 2121

PERTH
 (09) 279 4511

Queensland Report

State Secretary's Report - June 1990



Workplace Health & Safety Act

The Policy and Procedure Manual from the National Safety Council has been issued to all members.

Some tags and electrical record cards have been printed and have been made available to members at cost price.

Licence for hire fees and inspections of trailers

Further advice has been received from the Transport Minister regarding this licence to Hire. The Minister is of the opinion that if regular inspections are not carried out on trailers over 1.02 tonnes, then the industry will be open to backyard operators providing faulty equipment to the public. He feels that it is imperative that braking systems and couplings be maintained in first class order to prevent accidents and this can only be policed by imposing a licence to hire on trailers.

Trade Evenings

Cranford Products (distributors of Oleo Mac chainsaws etc.) will sponsor a trade evening for members in June.

Sebel Products will also host a trade evening for members in July.

Occupational Superannuation

The Association has been approached by H.A.R.I.B. who propose to establish an occupational superannuation scheme for members. Members have been surveyed to ascertain their needs in this area. Many members have not as yet complied with this latest Government legislation and unfortunately failure to comply will draw heavy penalties.

Industry News

Tom Jacobsen (Jayhire, Mackay) has advised that he has sold his business to Mr John Laub. Tom will continue with his party hire business, Fiesta Rentals.

Traineeship Scheme

The traineeship scheme commenced on 21st May with a full quota of students. Feedback to date has been very positive. Several members are involved in lecturing the students and also providing equipment for hands on demonstrations.

Training Guarantee Scheme

The Association will look at further training programmes for members and their staff which will satisfy the new legislation which requires employers with payrolls in excess of \$200,000 to spend at least 1% of their payroll on training.

Northern Roundup

The Northern Roundup was held on 9-11th June in Townsville. 20 hire companies from the north attended and 22 exhibitors presented a trade show for members. Thanks to Don Neate (Paramount Hire) for finding time to organise another enjoyable weekend for members.



KANGO 1400 BREAKER

MID YEAR RELEASE IN AUSTRALIA



THE NEW 1400 IS VERSATILE

Breaking up concrete or cutting away concrete and masonry, digging heavy clay, driving earthing electrodes, vibrating, tamping, compacting, floor cleaning, etc.

- A new tough 1400 watt motor drives the electropneumatic mechanism which has been designed with a minimum of moving parts to ensure ultimate reliability.
- Soft grip extension handle or two hand vertical operation (removable for working in confined spaces).
- Quick change latch mechanism. All Kango 900, 950 & 1100 series tools and accessories can be used with the 1400.
- Modular design for easy, uncomplicated servicing to keep down time to a minimum.

- Multi-position soft grip front handle. Can be rotated through 360° and grip can be locked in position fully forward, or back, to suit the operator.
- Hammer action automatically cuts out when tool is removed from the work surface.
- Soft grip handle mounted in shock absorbing material to protect the operator from high and low frequency vibration.
- 'Lock-on' Switch with comfortable long trigger.

KANGO AUSTRALIA PTY. LTD.

(Incorporated in N.S.W.)

61-63 GOVERNOR MACQUARIE DRIVE,
CHIPPING NORTON, N.S.W. 2170 AUSTRALIA

A member of the Dobson Park Industries Group

PHONE: (02) 727 0177 • FAX: (02) 727 0697

JADEN



Australian Design Award



Winner of Australian Design Award

AWARD WINNING FEATURES:

- Improved Arm functions & Bucket Roll Back
- Choice of engines
- Increased Traction
- Greasable Linkages

- Enclosed Chain Drive
- Heavy duty construction
- Many attachments

BRIEF SPECIFICATIONS

1850 long, 985 wide, 1250 high
weight: 500kg.

CHOICE OF ENGINES



41-43 ALEX FISHER DRIVE,
BURLEIGH HEADS,
QUEENSLAND, AUSTRALIA. 4220



P.O. BOX 54,
BURLEIGH HEADS. QLD. 4220
PHONE: (075) 93 4567
FAX: (075) 93 4398

THE PROMISE OF POWER

From Aggreko Generator Rentals

Aggreko's fundamental attitude to its

"Promise of Power" has led to the largest

generator rental fleet in the world with



hundreds of generators on location daily

providing the best guarantee

of all: that Aggreko will

always back it's promise

with more experience

than anyone else.

For mine or quarry,

oil rig or construction

site, Aggreko

have the power,



15 to 1825kVA in single units or in multiples

to suit your application • Cable

• Silenced Sets • Transformers

• Load Banks Resistive and Reactive



For obligation free technical advice on

the rental of your next generator contact

Aggreko Generator Rentals.

Melbourne Telephone (03) 587 5011

Facsimile (03) 587 5054

Sydney Telephone (02) 604 5166

Facsimile (02) 725 2964

Newcastle Telephone (049) 616 414

Facsimile (049) 623 030

Perth Telephone (09) 356 1511

Facsimile (09) 356 1390

Kalgoorlie Telephone (090) 912 059

Facsimile (090) 912 408

Adelaide Telephone (08) 277 0022

Facsimile (08) 277 0889

Brisbane Telephone (07) 277 0500

Facsimile (07) 274 2879

Darwin Telephone (089) 322 950

Facsimile (089) 324 134

Alice springs Telephone (089) 525 155

Facsimile (089) 534 477

Launceston Telephone (003) 318 222

Facsimile (003) 340 239

Hobart Telephone (002) 310 322

Facsimile (002) 349 725

Toll Free 008 335 268

24 hours 7 days

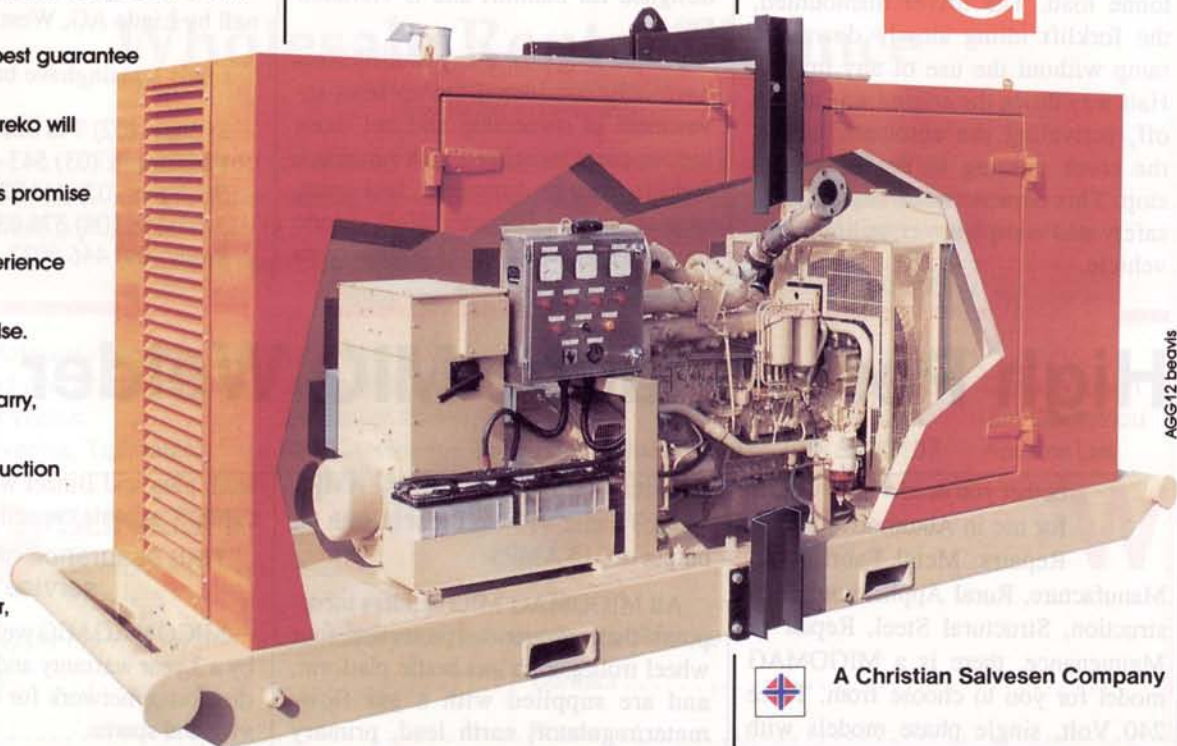

AGG12 beavis



A Christian Salvesen Company

Lansing explodes the myth behind the iceberg

At the recently held launch of the new 'H' series Linde forklifts, everything went off with a bang. Pyrotechnics were used to explode the tip of the iceberg which was the theme throughout. As the demonstration explained the tip of the iceberg represented up front investment of owning a forklift, whilst the 80 per cent below the line represented the hidden costs not often considered by the buyer at time of purchase. Confetti fell as a round of applause signaled the finale of a truly remarkable demonstration.

Many outstanding features of this new age in forklifts were demonstrated in a unique and impressive display.

During the show the unit was driven up a 1:2.7 ramp carrying a two tonne load. The driver dismounted, the forklift idling slowly down the ramp without the use of any brakes. Half way down the engine was turned off, activating the automatic brake, the truck coming to an immediate stop. This demonstrated unparalleled safety and complete versatility of the vehicle.



The new 'H' series Linde forklift being launched.

Another very effective demonstration of the capability of this stylish forklift was the see-saw. The vehicle was skillfully balanced in a backward and forward motion, the driver using only the foot control pedals, with no hands required to operate gear controls, showing complete driver control and ease of operation.

The drivers cabin is ergonomically designed for comfort and is vibration free.

For too long now many forklift users have only considered the up front investment of ownership and not those hidden costs associated with running a forklift, such as downtime, fuel costs, maintenance costs etc. Well, Linde have now exposed those hidden costs

and demonstrated how they can be reduced dramatically over the life of the truck, with their new hydrostatic drive forklift. Linde forklifts are powered by diesel or L.P. Gas and save up to 40 per cent on fuel costs, increase productivity by up to 30 per cent and reduce maintenance costs by up to 50 per cent - as they have no gear-box, no brake wear, no differential and no accelerator.

An optional five year maintenance package is available at minimal cost and can be varied to suit individual company and budget requirements.

The Linde 'H' series forklifts are the first of their kind in Australia, manufactured and distributed throughout Europe by Linde AG, West Germany but now readily available in Australia through Linde Lansing Pty Ltd since the recent acquisition of Lansing Bagnall by Linde AG, West Germany.

Linde Lansing have branches in:

Sydney: (02) 748 0211
Melbourne: (03) 543 4455
Brisbane: (07) 844 9281
Adelaide: (08) 376 0344
Perth: (09) 446 6022

High Performance MIG Welder

Whether you need a MIG welder for use in Automotive Smash Repairs, Metal Fabrication, Manufacture, Rural Application, Construction, Structural Steel, Repair or Maintenance, there is a MIGOMAG model for you to choose from. Three 240 Volt, single phase models with

capacities of 140, 220 and 240 AMPS and a 3 phase 415 Volt model with an output of 315 AMPS.

All MIGOMAG MIG welders incorporate thermal overload protection, four wheel trolley with gas bottle platform, and are supplied with a gas flow-meter/regulator, earth lead, primary

lead, plug and Binzel welding gun and cable of suitable capacity.

"Your assurance of quality and service"

MIGOMAG MIG welders are backed by a 3 year warranty and Australia wide distributor network for equipment, service and spares.

At last . . . specialised finance for dealers within the hire industry

Why haven't operators of General Handyman Equipment Hire and Party Hire businesses had access to the same specialised finance plan as dealers in allied Rental Businesses have had for close to 20 Years now?

That's right. Suncorp Finance Limited through its Wholesale Rental Finance Division offer a tailored finance plan to cover the acquisition of new equipment by dealers who operate within the Rental Industry.

"Although the Bailment Finance concept originated back in the days of black and white TV's, we now offer the possibility of being able to finance any product, brand, model etc.- as long as it is an item which will be rented or hired out." states Andrew Lee, Manager of Suncorp's W.R.F. Division in Melbourne.

Suncorp is of the opinion that many Independent Rental Business operators have difficulty in obtaining suitable

finance from traditional financiers because the equipment is to be used for rental purposes.

Items can be financed individually or in any quantity at any time. Therefore there is no need to hold stocks of expensive unproductive equipment.

Their Bailment Plan which has far more flexibility than that of a normal lease, has been perfected and fine tuned over many years and is the only finance plan W.R.F. offer - therefore they really know the rental business backwards!

Listed here are some of the benefits of the plan which will indicate to operators just how convenient Suncorp's Wholesale Rental Finance plan really is.

Items of stock are financed at wholesale prices. There is no need for a deposit up front and there is no residual payment at the end.

The period over which the items are financed is flexible. Depending on the equipment, the Dealer can nominate periods of between 12 months and 60

months.

After the last pre-selected monthly instalment has been paid, unencumbered title to the unit passes to the Dealer.

Individual items can be paid out at any time, which ideally suits the customer who may want to purchase an item that they are renting.

To help minimise setting up costs, Suncorp provide Sub-Hirers Agreements and other stationery required free of charge.

From time to time selected forms of advertising can even be subsidised.

Suncorp Finance Limited was formed in Queensland on March 1st 1986 with the amalgamation of three very large institutions - S.G.I.O. (Qld) Insurance, S.G.I.O. (Qld) Building Society and Permanent Finance Corporation Ltd.

Their Wholesale Rental Finance Division currently operates in all of the eastern states of Australia, Further information can be obtained from the State Managers.

Need Finance to Expand Your Rental Fleet?

Then talk to:

Wholesale Rental Finance

A Division of Suncorp Finance Limited
(Incorporated in Queensland)

They offer you specialised rental finance for your requirements including:

- Finance on ANY BRAND or PRODUCT of your choice • Minimum capital outlay • Lower Wholesale Price • Choice of 'Rent-Buy' periods — from 12 up to 60 months • Pay-out Unit at any time • No commitment to ordering quantities •

In the metropolitan area or in the country — big or small they welcome your enquiry



For more detailed information call them now...

Queensland and Northern Rivers: 30 Herschell Street, Brisbane.

New South Wales: 24 Market Street, Sydney.

Victoria, Riverina, Tasmania: 323 Camberwell Road, Camberwell.

Tel: (07) 236 2333

Tel: (02) 29 8241

Tel: (03) 882 2107

Chris Wikman

Jim Demetriou

Andrew Lee

To:



SUNCORP

FINANCE LIMITED (INC IN QUEENSLAND)
WHOLESALE RENTAL FINANCE DIVISION

Please supply me with further details about your Bailment Rental Finance

Company Contact

Address Phone

Down. For the count.

Downtime. Like death and taxes, it's one of the few things in life you can count on. And if you don't keep on top of it, you can find yourself out of the game. Permanently. But BP's range of Bartran hydraulic oils cuts downtime in half by lasting up to

twice as long. Fill out this coupon or ring our product advisory service on call free 008 033 558 and we'll let you know how Bartran hydraulic oils can help you stay up. And running.



ON THE MOVE

Bartran hydraulic oil cuts downtime in half.

Send to: BP Oil, Industrial Lubricants Division, GPO Box 5222BB, Melbourne, Vic., 3001. Please send me a Bartran technical information pack.

Name _____

Mr/Mrs

Initials

Surname

Address _____

Postcode _____ Telephone _____

Title _____ Company _____

Our field of business is: _____

Approx. litreage of hydraulic oil used per annum. _____

What brand of hydraulic oil do you normally use? _____

Hire gear a winner in Nyngan



A Kennards' pressure washer being used to clean up after the Nyngan floods.

A range of equipment from Kennards Hire passed a gruelling test in the clean-up after the devastating floods at Nyngan in NSW.

Kennards waived the hire fees for a group of Lions Club volunteers from Sydney, who went to Nyngan to help in the rehabilitation of the town.

The group took with them a tipper, trailer, two pressure washers, two carpet shampoo machines, two industrial vacuums, a floor polisher and a 7KVA generator. ClarkLift South Coast provided a bobcat. Their assignments included cleaning out farm haystacks and silos, cleaning up the Nyngan Public School and transporting furniture, personal effects and wall linings from flood-damaged homes.

The pressure washers and other cleaning equipment were invaluable for cleaning up the school.

The leader of the group, John Donald, said he had decided there was no point going to Nyngan without good equipment.

"I approached Kennards Hire and their response was very positive," Mr Donald said.

"After discussions with the Army co-ordinator, it was decided what equipment would be of most use.

"We were probably the best equipped of all the privateers at Nyngan."

Mr Donald said the experience showed the importance of team-effort and was a valuable guide to how volunteers should organise for any future effort.

"The most important thing to come out of this experience was seeing what can be achieved through people and businesses working together in a team effort."

Andrew Kennard, managing director of Kennards Hire, said Kennards was delighted to help the flood relief effort.

"We are a family company, and we believe in this type of community involvement," Mr Kennard said.

 **KÄRCHER**

Kärcher's new compact cleaners **AVAILABLE NOW!** Keeping Australia clean



HDS555C

- Hot, cold & steam.
- 1500 psi.
- Water cooled motor.
- Detergent tanks.
- Low fuel warning light.
- Weight 88kg.

HDS790C

- Hot, cold & steam.
- 2200 psi. (3PH)
- Water cooled motor.
- Detergent tank.
- Low fuel warning light.
- Weight 88kg.

**Heave-ho
...and off
they go!**

Kärcher's new compact cleaners are designed to fit quite comfortably into the back of your customers station-wagon.

Packed with 'customer' features, the HDS 555c and the HDS 790c offer **outstanding hire & rental value.** Combined with an ideal compact size and Kärcher's comprehensive range of accessories both machines are guaranteed to keep your valued customers coming back for more of the same!

For further information contact:

 **KÄRCHER** PTY. LTD.

HEAD OFFICE
Kärcher Pty Ltd
Quality Cleaning Systems
(Inc. in NSW)
2/158-168 Browns Road
NOBLE PARK 3174
Tel: (03) 795 4422
Fax: (03) 701 0010/701 0001

BRANCHES
NSW (02) 624 8511
Adelaide (08) 31 2792
Brisbane (07) 875 1525
Tasmania (003) 340 744

NEW ZEALAND
12A Ron Driver Place
East Tamaki, Auckland
PO. Box 58547
East Tamaki, Auckland.
Tel: (09) 274 4603
Fax: (09) 274 5609

PROFESSIONAL QUALITY FROM THE WORLD'S LARGEST PRODUCER OF HIGH PRESSURE CLEANERS

Reliability is the key to forklift use at Woolworths' Brisbane operations

The giant food retailing chain, Woolworths, has selected Clarklift South Queensland as supplier of a fleet of ten electrically operated forklift trucks at the Acacia Ridge and Rocklea distribution centres.

Value, price advantages, and proven performance over a long period influenced distribution maintenance manager Mr Bob Hingston in his decision to recommend the long term rental of three TM 16s and the purchase of seven EM 20s from Clarklift.

One EM 20 currently in use at Acacia Ridge is five years old, and according to Mr Hingston the excellent record of this unit ensured the purchase of the six other trucks in 1988/1989. In the tightly-timed, fully computerized distribution facility at Acacia Ridge, efficiency and reliability are critically important. Mr. Hingston explained that the warehouse operates a 24-hour service to the Woolworth stores throughout the state. Orders placed through the on-line computer system are processed and despatched overnight, meeting a tight timetable to ensure supply.

"This warehouse handles inwards between 6,000 to 10,000 pallets per week of around 5,000 product lines and can store 21,500 pallets", Mr Hingston explained. "Floor staff of about 170 provide our output to 170 odd stores of between 4,000 to 6,000 pallets per week over three shifts per day.

"The output of the warehouse is computer-organised and provides a 24-hour service to the stores to maintain stock at the highest possible level," he said.

In order to achieve these delivery schedules, operators of the Clark lifttrucks at the Woolworth plant may travel up to 40km per shift. The trucks are in constant use, and batteries are replaced in each on the average every five hours, Mr Hingston said.

Referring to the fresh produce operation at Rocklea, Mr Hingston selected the Clark TM 16s because, in his own words, "They were the right units for the job." He stated that these three-wheeled, battery powered lifttrucks are fast to operate, easy to manoeuvre, and compact, so they are ideal for work in the narrow aisles of cold rooms.

The Clark EM 20 four-wheeled forklift truck is pneumatic tyred, compact, and easily manoeuvrable. According to Clarklift Product Manager, Michael vanden Broek, the hydrostatic steering of the EM 20 offers the advantages of economy and low maintenance, making the units ideal for use in tight warehouse scheduling. The German-designed, Australian manufactured forklift truck has extremely light power steering, driven by a very low current permanent magnet motor for minimal power consumption, operating on a delay-timed mechanism which switches the motor off when steering is not required.

Both the Clark TM 16 and the Clark EM 20 generate minimal noise, and are electrically operated, therefore ideal for use in food storage areas. With lifting capacities of 1.6 tonnes and 2 tonnes respectively, these forklift trucks offer driver comfort, and have a reach capacity of up to 3.7 metres depending on load. The Clark TM 16 and EM 20 perform consistently and economically over long periods, offering economies of up to one third of overall unit purchase and running costs.

Further details may be obtained from:

Mr Michael vanden Broek
Clarklift Queensland
215 Evans Road
Salisbury 4017
Ph: 07 277 3233 Fax: 07 875 1160

DUNLITE
PORTABLE POWER

**reliability...
it's a goldmine!**

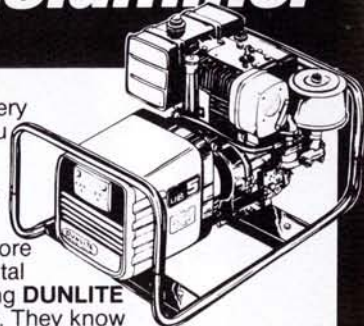

To your customers every piece of equipment you hire out has **your** name on it. If it doesn't do the job ... if it's unreliable, then so are you. That's why more and more hire and rental companies are stocking **DUNLITE** power generating sets. They know that DUNLITE'S proved performance and reliability will result in customer satisfaction and return business. They know, too, that DUNLITE'S ruggedness means reduced maintenance — less replacements. That adds up to more income, less expense, more profit. So include DUNLITE generating sets in your inventory. Their portable power packs range from 400 watt units to 7.5 kVA. Or if you wish to carry a 1250 kVA unit they can now supply that too!

DUNLITE gen. sets
... they're a
licence to print
money.

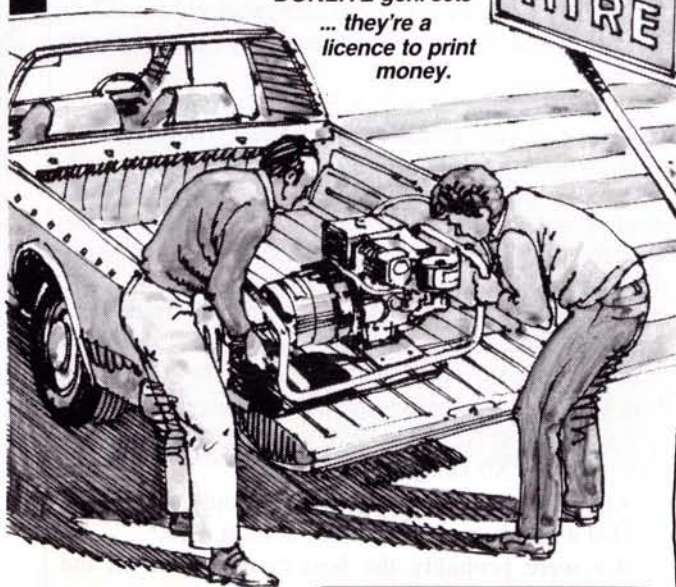

**Need power?
DEMAND...**

DUNLITE
PORTABLE POWER

DUNLITE, 11 Manton Street, HINDMARSH S.A. 5007, Phone (08) 346 3832
Please send me further information on your generator range

NAME _____

ADDRESS _____

POST CODE _____

SYDNEY 018 256 975, MELBOURNE (03) 699 1655
BRISBANE 018 735 505, PERTH 018 910 644

Westwood Engineering hosts first Annual Dealer Conference

Westwood Engineering played host to their top 35 dealers in Perth last week, for their First Annual Dealer Conference.

The venue was the exclusive Burswood Hotel Casino complex where the dealers heard about ... and used a variety of New Products.

Among the items released was an exciting new Fluid Drive (Hydrostatic) ride-on which is expected to sell at up to \$500.00 less than the competition at only \$3,300.00 plus freight.

It features instant forward/reverse selection and is available with Briggs & Stratton or Honda engines. The choice of cutters is 30" or 36".

Westwood also introduced a self powered 'Back Hoe' and a 'Muck Truck'.

The Muscleman Hoe is ideal for small builders and should be a winner in the



One of the new products from Westwood at test.

The Westwood Muck Truck is unique, it will get in and out of confined spaces where few other ride-on dumpers can go, shifting muck - 400 kgs of it - through a 1170mm gap and there's more! Powered by twin hydrostatic motors, it's self loading, will skid steer in its own length and is self trailering - so it's on site fast.

The Westwood Skip Truck is a Muck Truck with optional 7 cubic foot discharge hopper ... giving you a skip or trailer filling capability plus all the versatility of a Muck Truck. It remains stable however hard you shake it, even with a full load at full

stretch. So no more chaos with barrows, or risking life and limb on slippery planks.

Trade enquiries to: Fred Tyrrell
Westwood Engineering Aust. Pty Ltd
4/5 Samantha Court Scoresby VIC 3180
Ph: (03) 763-8200
Fax: (03) 764-1224

hire industry as its self trailering feature will save time and money getting it to and from site. It has a mighty 1.9 tonne tear out force, digs down 2.2m - yet it weighs only 365 kgs and reduces down to just under 1m wide. Which means you can have the digging power of a big machine just about anywhere you need it.

HIRE KIT



PROVEN RELIABILITY

Specifically designed for the hire market, this well proven Electric Eel Kit allows for instant parts check on return and includes, as standard, sufficient

tools and cables for most drain cleaning jobs.

Highly cost effective Electric Eel is the machine preferred by both plumbers and handymen.



AVAILABLE FROM:

QLD: Gregory Machinery, 1 Vulture Street, WEST END, QLD 4101 — Telephone: (07) 884 4433
NSW: SECA Aust, 11 Carrington Road, MARRICKVILLE, NSW 2204 — Telephone: (02) 559 5622
VIC: OBE Trading, 65 Taunton Drive, CHELTENHAM, VIC 3192 — Telephone: (03) 584 7211
SA: METCO, 237 Richmond Road, RICHMOND, SA 5033 — Telephone: (08) 234 0566
WA: Flextool (Aust) Pty Ltd, 3/47 Tate Street, BENTLEY, WA 6102 — Telephone: (09) 451 2077
NZ: Moulpak Products, 17 Parity Place, GLENFIELD — Telephone: (09) 480 8096



Andrews Gasmaster - energy sense into action

Industrial heating invariably means keeping people warm to maintain productivity. With the onset of cold weather, the conventional solution is to fire-up a main boiler plant to heat the entire premises, with all of the associated operating and maintenance costs and ever increasing fuel bills.

Instant flexible heat

Consider the energy efficient alternative - **ANDREWS GASTMASTER PORTABLE AIR HEATERS.**

You can achieve on-the-spot heat instantly, without waste. No expensive warming up period, simply wheel into position and switch on, to provide safe controllable heat, when and where you want it. Used singly or in multiples, highly manoeuvrable and robust Andrew Gasmaster portable heaters burn LP Gas, and deliver heat

ranging from 30,000 to 260,000 Btus per hour.

100% Efficient

Compared with the 75% efficiency, at best, of central boiler plant, Andrews Gasmaster direct fired heaters are 100% efficient, based on Nett Calorific Value. The Capital cost of an Andrew Gasmaster portable heater is at least 50% LESS than a fixed warm air system of equivalent Btu output.

Reliability

In addition to twelve months warranty, product design features facilitate economical preventative maintenance and simple servicing.

Well-proven heat

The Andrews Gasmaster range has proved highly reliable in service over

many diverse industrial and commercial applications and withstood the extreme conditions experienced by the **BRITISH TRANSGLOBE EXPEDITION.**

So before you switch on your heating system this winter.....stop... consider the economic alternative.

ANDREWS GASTMASTER PORTABLE AIR HEATERS, they turn ENERGY SENSE INTO ACTION.

LP gas models

G125 Input 30,000 to 125,000 Btu/H

Heated Air 400 CFM

Consumption 0.6 to 2.6 Kg/hr

G260 Input 65,000 to 260,000 Btu/H

Heated Air 1200 CFM

Consumption 1.36 to 5.5 Kg/hr

BRICK CLEANING MACHINES

Ideal for Rental

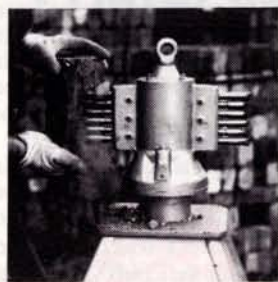

NOW!

Two men can clean up to 2000 bricks per day.

Simply Amazing

Call Rick Venn

AUSTRALIAN BRICK CLEANING CO.

"Bundaleer", Reynolds Rd., Eltham Vic. 3095

Phone: (03) 439 9293 - (03) 437 1484

Fax: (03) 417 5873 - (03) 439 5785

Economic INSTANT HEAT

LP GAS PORTABLE AIR HEATERS

- 2 Models - 30,000 BTU's to 260,000 BTU's • Instant flexible industrial heating • Safe and Controllable • 100% efficient performance (based on Nett Calorific Value) • Lightweight
- Compact design • Simplicity of operation • G.A.N.Z. approved
- Reliable in service
- Thermo Automatic models available

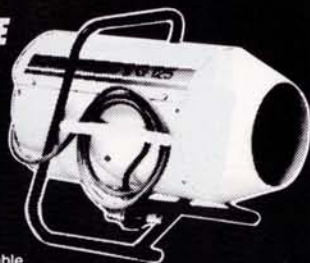

ANDREWS & Gasmaster
"PORTABLE LP GAS HEATERS"
"QUICK TO HEAT" - "HARD TO BEAT!"

AVAILABLE FROM:

Auckland Office:
Private Bag 8, Panmure
Auckland, New Zealand.
28 Lunn Ave
Ph (09) 570 1159
Fax (09) 570 2511
Telex 60883 WESCORP



Manufacturers of traffic control equipment

- ★ **BARRIER BOARDS — PVC and Timber**
- ★ **BARRIER LEGS**
- ★ **FLASHING LAMPS — Steel and Plastic**
- ★ **TRAFFIC CONES**
- ★ **SIGNS — Roadwork and Safety**
- ★ **PLASTIC SAFETY FENCING and STAR POSTS**
- ★ **SAFETY VESTS, HATS & FLAGS**
- ★ **WARNING TAPE**

Servicing the Hire Industry

ROAD SIGNS

12 ADDISON ROAD, MARRICKVILLE
PH: (02) 51 4547, (02) 516 1467
FAX: (02) 519 9936

Victorian Report



Aluminium Mobile Scaffolding

Several items of interest relating to mobile scaffolding have been reiterated by the Department of Labour and members should be aware of these points:

- it is the supplier's responsibility to supply assembly instructions with the scaffolding. If you are not supplying an assembly drawing to every customer you are leaving yourself open to prosecution;
- it is the supplier's responsibility to provide the correct ladder for the height of the scaffold being used;
- if an aluminium tower is to be used as an external scaffold, adjustable plates are required. Stabilisers can be used to take the weight off the castors and give stability to the tower;
- it is illegal to mix aluminium scaffold-

ing components from two different companies to make one tower, even if they fit. If there is an accident and someone is injured the hirer would be completely responsible.

Electrical Testing Program

Victorian hire companies are required to test all electrical appliances prior to every hire, a standard "service completed" type ticket is all that is needed to identify the service is complete, including the electrical test. The ticket must show the date, the person's name and his certificate number. No recording of the test is needed.

However the requirement for construction and demolition sites is different. Testing is needed on products at six monthly intervals, again no recording needed. It is recommended however

that companies test, tag and record on a six monthly basis, as well as the daily requirement, or as the tag deteriorates go through the procedure again. It should be noted however that the test period for E.L.C.B.'s is every three months.

Skid Steer Loaders Machinery Safety

A special meeting has been arranged for late June which will be addressed by Dr. John Higgins, Manager, Equipment Safety Branch, Department of Labour. He will speak about the changing patterns of the legislation which will come into effect in July 1991; the relative responsibilities of the various parties; accident reporting; and the action necessary to facilitate these aspects. All members have been invited to this meeting.

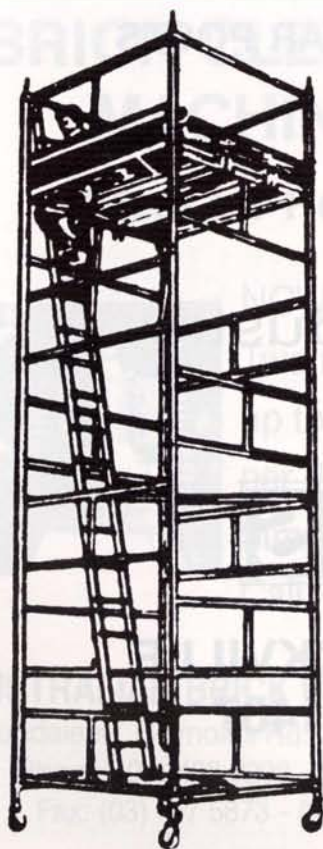

NO-BOLT SCAFFOLDS

ALUMINIUM TOWERS

Designed for the Hire & Rental Industry

NO-BOLT Aluminium Mobile Scaffolding has been designed with quality in mind. Using aluminium with a wall thickness of 4.7mm it is lightweight, yet strong enough to withstand the abuse handed out to hire equipment. A simple design for easy handling, stacking and erecting. Fully D.L.I. approved and guaranteed.

NO-BOLT SCAFFOLDING PTY. LTD.

22 Dingley Ave., Dandenong 3175
Telephone (03) 793 2355

CALL NOW TOLL FREE
008 33 1478

Expansion completed by Form-it

Form-it has led the field in numerous aspects of fibreglass manufacturing during their 25 years in the Industry. With expertise in design and fabrication, they have introduced many new products to the market place over the years, each receiving acclaim from the appropriate sectors.

The manufacturers of fibreglass portable on-site toilets and showers, Form-it has supplied NSW and QLD for many years. Now with expansion programs completed and additional capital injected into research and marketing areas, the Company is in a position to forge toward a larger market share and actually reduce prices at a time when competitors are opting for the reverse.

Form-it's portable toilets and showers have proven to be extremely durable but lightweight, easily transported and hygienic. These units are completely fibreglass one-piece moulded, thus reducing the maintenance factor while making cleaning a quicker, easier task.

A new addition to the range of toilet models is a 'double version'. This is two separate toilets mounted on one heavy duty galvanised trailer. The advantages are obvious. Transportation time and costs are reduced and, as is often required, male and female facilities are provided with the minimum of fuss.

Another new model is the 'bore-hole toilet'. All the comfort features of earlier models are included, but this one has been specifically designed to suit the outlying areas where sewer connections or regular emptying of effluent tanks is either impossible or impractical.

To please the 'die hards' and the 'not as yet converted', Form-it has now designed and fabricated a steel body toilet, the proof that the Company is both versatile and responsive to market requirements. These units still incorporate the features of all previous models.

Consistent with the earlier model portable toilets, self closing hinges are fitted, skylights and fly screened vents are fitted for ventilation and insect/weather proofing. Exterior gelcoat finish alleviates re-painting of fibreglass models and also acts as a weather protectant while the interior flow coat finish aids hygiene and makes cleaning quicker and easier. Very simple operating instructions are affixed in all units. Outer colours may be altered to suit desired colour schemes.

As manufacturers of the Top Hat Yacht, Form-it Fibreglass is equipped for the precision and strict quality control warranted in the fibreglass boat building Industry. This same approach and production methods are adopted in the fabrication of all products manufactured by the Company.

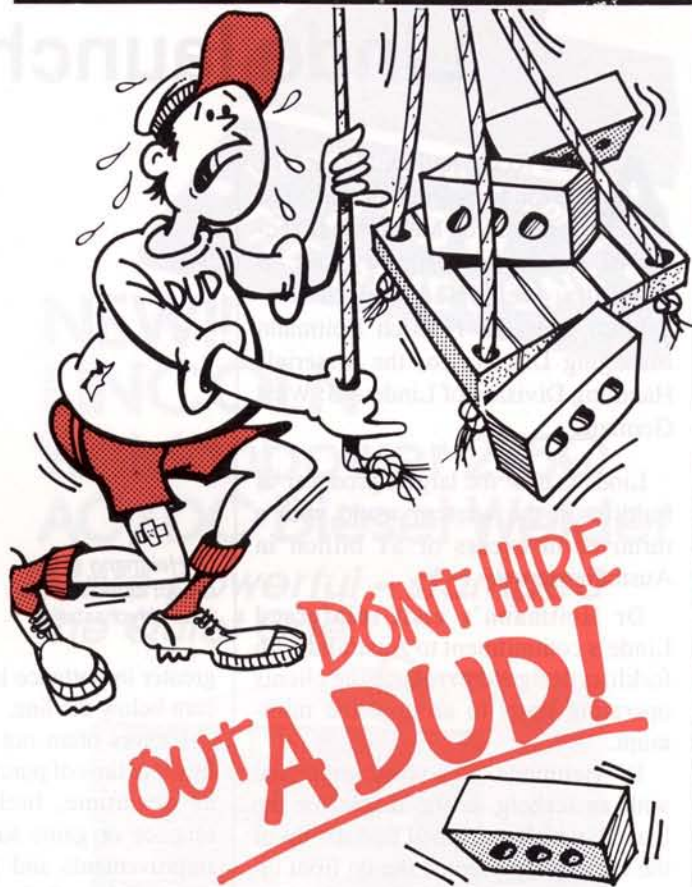

Breakdowns Cost Money!

Unreliable equipment can quickly lose you your business. The Electric Builder's Hoists from Transmission Technology are designed to operate effectively and economically in any situation that requires lifting loads to above ground working areas. Builders, painters, signmakers, bricklayers and roof tilers will appreciate the features that make these hoists simple and safe to operate;

- 240 Volt Double Barrow
- Automatic Level Stop
- Overload Protection
- Removable Sides
- Fully Galvanised
- Relocated and rigged again within hours

INQUIRE ABOUT FRANCHISING



Available in a range of lifting capacities and heights, these hoists are the right choice for hirers supplying to industry.

Don't look like a dud. Call Transmission Technology and let them show you how easy it is to supply quality Electric Hoists without worries.

TransmissionTechnologyPtyLtd

Unit 1 59 Prince William Drive, Seven Hills, NSW 2147, Australia
Phone: (02) 674 1611 Fax: (02) 674 5123

Linde launch voted No.1

At the recent national launch of the Linde hydrostatic forklifts, Des McEvoy Managing Director of Linde Lansing Pty Ltd in Australia, welcomed their distinguished guest Dr Henrich Heitmann Managing Director for the Materials Handling Division of Linde AG: West Germany.

Linde is now the largest producer of forklifts in the western world with a turnover in excess of \$1 billion in Australian terms.

Dr Heitmann's visit reinforced Linde's commitment to Australia with forklifts designed to reduce the clients operating costs to an absolute minimum.

Dr Heitmann was most impressed with an iceberg as the theme for the launch, which explained that the tip of the iceberg represented the up front investment in a forklift but of much

Dr Heitmann at the recent launch of the Linde Hydrostatic



greater importance is the hidden 80 per cent below the line.

Factors often not considered by the buyer at time of purchase, are costs such as downtime, fuel costs and maintenance or gains such as productivity improvements and product care. This dramatic launch showed how total costs

could be reduced to a minimum with the new Linde hydrostatic forklifts.

Stewart Pursehouse, Linde Product Manager said at the launch, "These totally new hydrostatic forklifts now provide Australia with the productivity gains and reduced costs this country so badly needs."

A REAL GUTSY PUMP!



**THE HIRERS
CHOICE
A PROVEN
WINNER FOR
YOUR FLEET**

**CALL AT
OUR
STAND AND
ASK ABOUT
OUR
CONVENTION
SPECIALS**

Pumps upto 20mm (3/4") Solids

• WATER • MUD • OIL • SLUDGE • SILT

... IN FACT JUST ABOUT ANYTHING THAT WILL FIND ITS WAY THROUGH THE INLET STRAINER.

THE GENUINE FLEXTOOL

Flextool (Aust.) Pty. Ltd.
191 Wellington Street,
Collingwood Vic. 3066
Telephone (03) 419 6300

Sydney
29 Crescent Street,
Rozelle, N.S.W. 2039
Telephone: (02) 818 5722

Brisbane
17 Ross Street,
Newstead Qld. 4006
Telephone: (07) 252 2306

Adelaide
Unit 25/937 Marion Road
Mitchell Park, S.A. 5043
Telephone: (08) 298 1388

Perth
3/47 Tate Street,
Bentley W.A. 6102
Telephone: (09) 451 2077

Australian engineer to head International Crane Code Committee



Lawrence Perrin

The International Organisation for Standardisation based in Geneva, Switzerland has announced the appointment of Lawrence Perrin B.E. (Mech.E.), as chairman of the international crane code committee.

Mr. Perrin is the Director of Engineering for Armstrong Holland Pty. Ltd. He has been associated with crane code standards since the early

1960's. Mr. Perrin was one of the first dozen or so mechanical engineers to graduate from Sydney University following the separation of the mechanical and electrical degree courses. Since graduation, he has spent his whole career with Armstrong Holland.

Further information:

Armstrong Holland Pty. Ltd.,
Cnr. Rawson & Highgate Streets,
AUBURN N.S.W. 2144
Telephone: (02) 748-4445
Facsimile: (02) 748-3971.

Go karts - go anywhere!

Off Road Go-Karting is the latest trend in motorised recreation. To meet the needs of the young and not so young, Westwood Engineering have de-veloped a gutsy little runabout which is expected to sell at about \$1,500.00. Westwood say it will go "just about anywhere".

It has big wheels with chunky tyres, a strong chassis and an integral roll cage to protect the driver from low branches as he hurtles across the countryside with his bottom only centimetres off the ground.

The Westwood Go-Kart is designed for 12 year olds upwards and the brake and accelerator pedals are adjustable. Power is provided by a 5HP 4 stroke engine.

Westwood believe that Go-Karting is a great profit opportunity for their garden/agricultural machinery dealer customers.

Trade or Retails enquiries to:

Fred Tyrrell,
Westwood Engineering Australia Pty Ltd
4/5 Samantha Court, Scoresby VIC 3180
Ph: (03) 763-8200; Fax: (03) 764-1224



NEW!!
LINCOLN
Weldanpower 275Q
AC/DC Diesel Welder
More powerful - stamped
the Quiet One.



WELDANPOWER 275Q

40-300 amps AC
40-270 amps DC

cv - 200 amps (DC) @ 25V @ 100% duty cycle

THE MULTI-PROCESS MACHINE

DC FOR STICK ELECTRODE WELDING

Runs electrodes for stainless, alloy and high tensile welding and for hardsurfacing. DC TIG welding may be done with Hi-Freq.

AC FOR STICK ELECTRODE WELDING

Powers Hi-Freq. for AC TIG welding.

POWERS LN22 & LN25 WIRE FEEDERS FOR CONTINUOUS WIRE WELDING, MIG OR GASLESS

240 VOLT AC, 50 Hz POWER

Long-term primary, and temporary standby, or emergency power, using engine manufacturer's recommended running-in and maintenance schedule.

LINCOLN
ELECTRIC

THE LINCOLN ELECTRIC COMPANY
(AUSTRALIA) PTY LTD (Inc. in N.S.W.)
35 Bryant Street, Padstow, Sydney NSW 2211
Telephone (02) 772 7222. Branches in every State.
Dealers all over Australia.

LE 202 H2CV

INTRODUCING THE NEW WESTWOOD MUCK SHIFTERS

If access is tight, and your only option is a pick, shovel and barrow, or you're using big machines – at big prices – for jobs which just don't need all that power, the Westwood Muck Shifters are what you've been looking for. They'll save you effort, save you time and save – or even make – you money.

LOADS MORE

Digging Muscle

The Westwood Muscleman will dig deep – 7 feet deep. It's tough – you can really drive it hard. Yet it will go through a standard doorway. It's also self-trailerling, so it's on site fast, way ahead of big machines. More than that, it's so stable and simple to operate that a complete novice can be operating it with total confidence within an hour.



LOADS MORE

Carrying Muscle

The 46 inch wide Westwood Muck Truk is a highly-maneuvrable ride-on dumper. It will carry 400Kg with ease... and it's self-loading and self-trailerling – the ideal companion to the Muscleman. So now there is an alternative to the barrow for shifting muck when access is a problem, or where big machines cause obstructions, such as in town centres or on road-side sites.



LOADS MORE

Filling Muscle

There's more to the Muck Shifters than just digging and carrying. If you need to load... almost anything... into a skip, the Westwood Skip Truk will do the job. A high-lift variant of the Muck Truk, it will load 7 cu. ft. in just five seconds – with the same versatility and ease of access.



FOR FURTHER INFORMATION CONTACT:

WESTWOOD ENGINEERING PTY LTD

EASTERN STATES:-

FACTORY 4-5, SAMANTHA COURT, SCORESBY 3180. TEL: (03) 764-1193. FAX (03) 764-1224

WESTERN AUSTRALIA:-

126-132 SHEFFIELD ROAD, WELSHPOOL 6106. TEL. (09) 451-3622 FAX. (09) 351-8290

South Australia Report

Legislation - The Flavour of the Month in S.A.



1. Consumer Safety

Following on approach by representatives from the Department of Labour and the Department of Consumer Affairs, the S.A. Region is to develop a Code of Safety Practice. The South Australian code will be based upon the Draft Policy and Procedure Manual as developed by the Queensland Region. Our thanks to the Queensland Region for providing a copy of their draft and for the work and effort they put into the document.

2. Manual Handling

A South Australian State Version of the "National Standard for Manual Handling and National Code of Practice for Manual Handling" will become law in

October 1990. Firms will be obliged to put in place a Code of Practice for Manual Handling at Enterprise Level.

A document is being developed for members consideration and guidance in this area. A Special Workshop on Occupational Health and Safety is, as a result, planned to be conducted for members on the 9th of August 1990.

3. Red Alert System

A "Red Alert" System has been put in place, an early warning system to advise members of cases of theft from other members premises.

4. Convention Update:

1990 Adelaide Hire Expo

A briefing meeting was held on the

25th of May 1990 to answer any questions sponsors and/or exhibitors may have had at that point in time. The level of Sponsorship received to date has been most pleasing as have been bookings for Exhibition space. All speaker arrangements have been finalised and Social Activities organised. It is now a situation of "All Systems Go!"

Registration forms for delegates have been printed and posted to those persons who have registered for Conventions previously. Registration forms are readily available from:

Elliservice Convention Management
PO Box 753, Norwood SA 5067
Tel: (08) 332 4068, Fax: (08) 364 1968
S.A. looks forward to welcoming you all there!

WHAT'S NEW IN THE HIRE & RENTAL INDUSTRY?

E-Z Dumper

IT'S PORTABLE

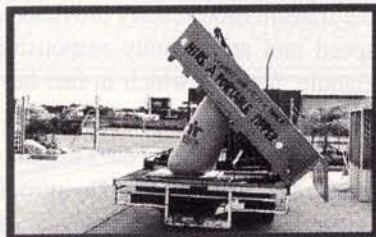

THE NEW PORTABLE UTE TIPPING BODY

- Fits all style side ute – Ideal for hire – no fitting requirements – Lifts one tonne – Operates in seconds – Mobile models available – Exhaust gas or compressed air operated – we will design to your needs.

For more information phone Alan Keith (07) 268 7799

Troltip Australia, 237 Fison Avenue, Eagle Farm Qld. 4007. A unit of the Nathan Group

Mustang broadens range

Following the success of the Mustang range of Skid Steer Loaders and New Generation Trenching equipment, Austoft Industries Ltd are introducing into Australia a range of compaction equipment which will also carry the now famous Mustang badge.

These Vibratory Road Rollers are manufactured in the UK by Benford Limited one of the Austoft sister companies.

Benford have been manufacturing and supplying rollers and other construction equipment to their own domestic market plus substantial quantities for export to various overseas markets for more than 20 years.

Since the introduction of road rollers in the mid 1970's, Benford have built up a reputation, second to none, for reliability of product and a first class after sales service.

Austoft/Mustang intend to carry on this well established tradition.

The long term goal of the Austoft team is to obtain a market share which will enable all of this equipment to be manufactured in Australia

The Mustang Vibratory Roller range includes Single and Double Drum rollers in walk behind, Mobile-Breaker-Rollers derivatives and Tandem Rollers, both articulating and rigid chassis models, covering the most widely used roll widths in the small-to-medium duty compaction (450-700 and 700-1300kg/m) categories.

The Mustang rollers use the hydrostatically controlled, hydraulic drive system.

This type of system requires fewer component parts and the transmission readily provides infinitely variable travel speed and an instantly responsive form of Dead Man's Handle, features which in fact have made the rollers very popular.

The introduction of the Mustang Road Rollers is only the beginning, Austoft intend to introduce other equipment into Australia over the next few years which will enhance their current market share of construction equipment.

The long term goal of the Austoft team is to obtain a market share which will enable all of this equipment to be manufactured in Australia.

The Bianco Diamond B Saw cuts work in half!

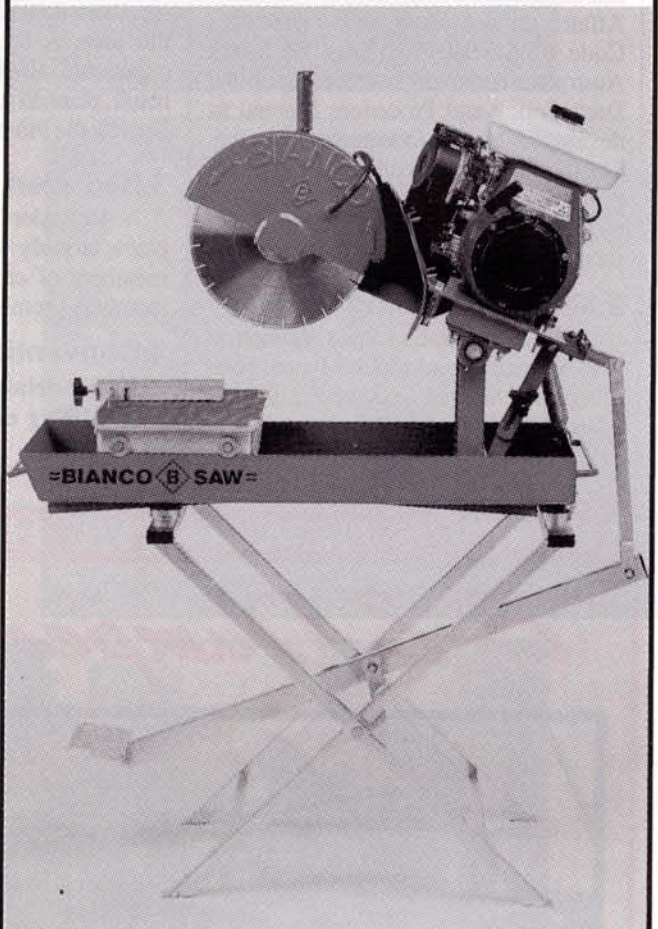

The Diamond B masonry cutting saw is sold and serviced by Bianco Builders Hardware
178 Gorge Road, Newton, South Australia 5074
Telephone (08) 336 6666 Fax (08) 336 6429



AT *oldfields* YOU CAN HIRE OR BUY THE LATEST IN MOBILE ALUMINIUM TOWERS

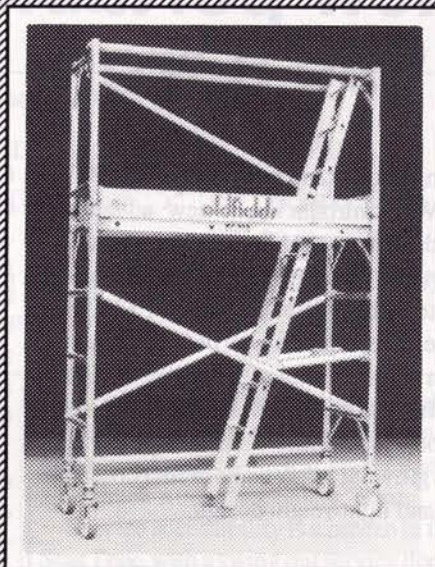
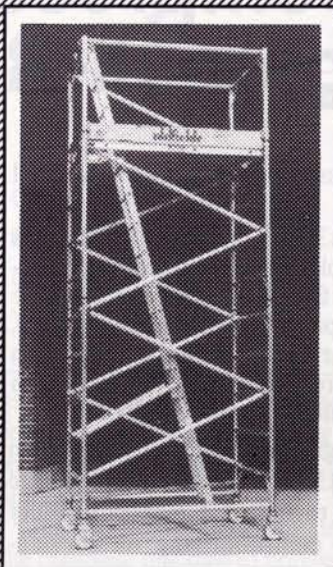
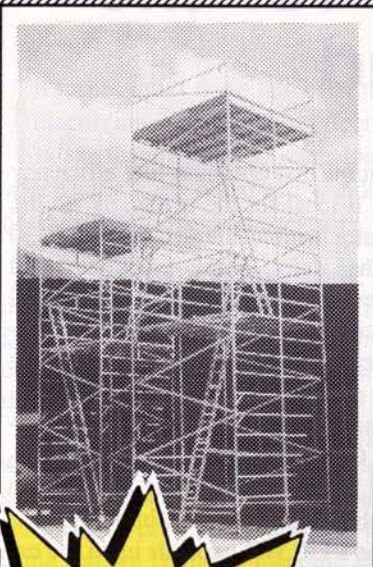

Available now

AND THE LATEST IN AIRLESS PAINT SPRAYERS!

The Oldfields Super Series

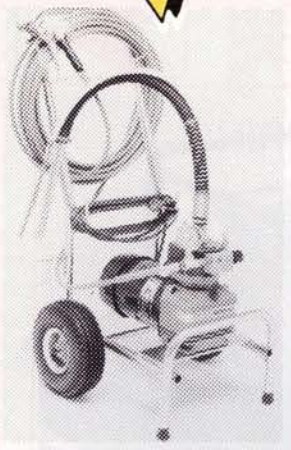

SUPER 60

Electric Powered

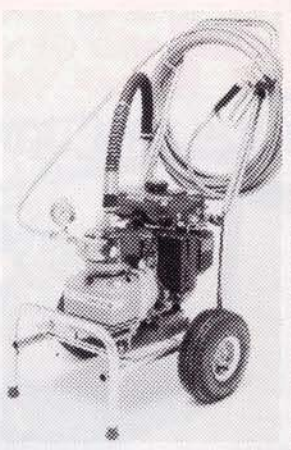

SUPER 60 GE

Petrol Powered



SUPER 70

Electric Powered

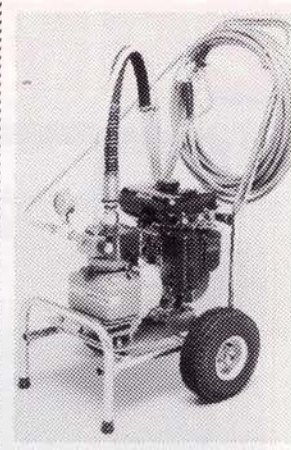

SUPER 70 GE

Petrol Powered

**oldfields
HIRE**

Plus a full range of aluminium step and extension ladders.

SYDNEY (02) 648 4133
 MELBOURNE (03) 326 6411
 BRISBANE (07) 273 1755
 PERTH (09) 244 2245
 AUCKLAND (09) 645 313

OLDFIELDS PTY. LTD. Hire Division
 Unit 12-1 Benelong Rd., Homebush, N.S.W. 2194
 Ph: (02) 648 4133 Fax: (02) 648 3073

New portable compressor for the 1990's from Ingersoll-Rand

Ingersoll-Rand has launched the P130 WD, introducing a new advanced design to the Company's range of Portable Compressors, the most complete in the market place. The P130 WD meets the requirements of the Construction Industry moving into the 1990's - including enhanced security features, good accessibility for maintenance and the growing importance of fuel efficiency and lightweight design.

The P130 WD is powered by the latest Series Deutz F3L1011 providing 41 hp. This high technology engine powers the compressor to produce 127 cfm (60L/s) at 100 psig (7 bar). Not only does this rating give it the power to run two (2) 25 kg Paving Breakers, but the same Breakers can be stored in two (2) internal tool boxes within the

Compressor's strong lockable steel canopy.

The P130 WD comes equipped with a full complement of standard features including a fold-away lifting bail, lockable control panel for enhanced security, a wrap-around moulded bumper with integral recessed lights for protection and moulded wheel fenders.

The lightweight and compact design of the P130 WD gives it the advantage of easy towing and manoeuvrability without compromising on serviceability. Designed with the Serviceman in mind, all areas are easily reached. The direct drive air end includes a standard Warranty protection of two (2) years or 4,000 hours.

The requirements met by the design of the P130 WD incorporate features for the owner, Operator and Serviceman. Very high reliability, minimum

downtime and optimum fuel efficiency make it ideal for the owner. With the Operator in mind, the design of the P130 WD has quiet, simple quick start and convenient controls. Finally, extended life components and ease of accessibility are noteworthy from a service point of view.

Since building the world's first Portable Compressor in 1902, Ingersoll-Rand has been pioneering advances in Portable Compressor Technology.

The P130 WD expands upon the experience and brings to the industry a new line quality products in step for the 1990's.

Contact:

Ingersoll-Rand (Australia) Ltd.,
 (03) 794 1611 (02) 648 5055
 (07) 277 3511 (077) 251 660
 (08) 352 6122 (09) 277 2211
 (090) 93 1647

"AETCO POWER KING WELDERS AND GENSETS"



WELDER

Combine the mighty power of KOHLER with EUROGEN alternator/welder. This 4 in 1 utility work tool provides a 270 amp. welder at 60% duty cycle, 8 kva, 3 phase, AC 415 volt supply. 3 kva, one phase AC supply, battery charging 12/24 volt, 25 amps., 20 h.p. KOHLER engine which is aircooled, has a 23 litre fuel tank, low oil engine protection, electric start, encased in a heavy duty powder coated roll frame. A real must for any busy maintenance man or factory workshop.

Contact AETCO now and we can help solve your generator and welder problems.
Power King Generators 2-15 kva — Petrol or Diesel also available



AUSTRALIAN ENGINE & TRANSMISSION COMPANY

N.S.W.	VIC.	QLD.	S.A.	W.A.
Tel: (02) 684 4666	Tel: (03) 398 5211	Tel: (07) 277 2333	Tel: (08) 349 7442	Tel: (09) 279 4511
Fax: (02) 684 4470	Fax: (03) 398 6196	Fax: (07) 875 1457	Fax: (08) 349 7886	Fax: (09) 279 1602

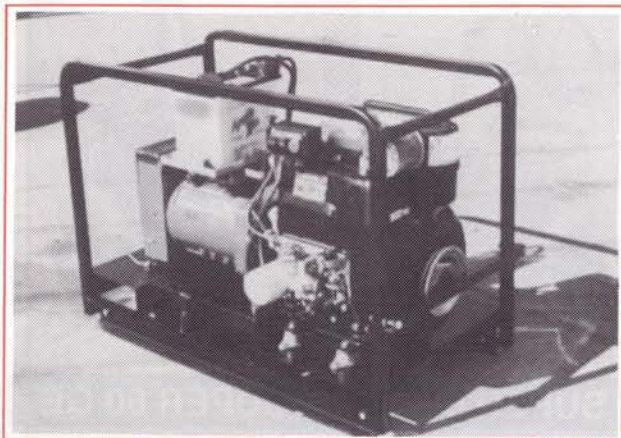

DIESEL GENSET

The matched quality of twin cylinder diesels with the reliability of EUROGEN alternators.

- ★ No extras or options required, these units are ready to run.
- ★ Electric start units also have rope start in the event of a flat battery.
- ★ Units proven throughout the world. Over 10 million engines sold since 1919.
- ★ Heavy duty roll frame for protection and mobility.
- ★ Twin cylinders with cartridge oil filter.
- ★ Electric start units include battery. ★ Oil bath air cleaner.
- ★ Forced lubrication. ★ Cast iron cylinder.

Skid steer safety solution

In recent times there has been much discussion and debate concerning safety features of skid steer loaders which may have prevented accidental deaths of inexperienced operators.

Scat Trak skid steer loaders, distributed by Intrac (Sales) Pty. Ltd of Dandenong, Victoria, feature a number of safety devices for operator protection.

All Scat Trak machines are equipped with a passive operator restraint bar as well as a seat belt. The "seat bar" is designed to prevent an operator from being thrown from the machine in the event of a rollover should he be foolhardy enough to operate the loader without first fastening the seat belt. A certified R.O.P.S. canopy is fitted to all Scat Traks sold in Australia.

Raising the seat bar activates a mechanical linkage which locks out the loader hydraulic controls to prevent ac-

Brief operating specs are as follows:-

	1000HD	1300HD
Operating Load	454kg (1000lb)	590kg (1300lb)
Engine (Kubota)	23.4kw (31.4 HP)	29.8kw (40HP)
Operating weight	2200kg (4330lb)	2427kg (5350lb)
Width	1448mm (57")	1448mm (57")

cidental loader arm movement and restricts machine movement by extending travel locking pins into the rear sprockets.

These features effectively neutralise the complete machine to prevent crushing injuries which most commonly occur when entering or exiting similar machines not equipped with adequate safety devices.

Scat Trak skid steer loaders are currently available in two sizes, the 1000HD and 1300HD with a larger machine due for release late this year.

A full range of attachments is also available for use and can be swapped over quickly and easily with Scat Trak's standard "Quick Attach" mounting frame.

Service accessibility is a breeze in the Scat Trak, with a swing out service door, hinged seat and removable guard giving unrestricted access in seconds, without using tools.

Scat Tracks are currently represented in all states except Tasmania.

For further information contact -
Intrac (sales) Pty. Ltd.

Ph (03) 791 3300, Fax (03) 791 8398

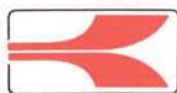

KOSHIN PUMPS

HIRE INDUSTRY PUMPS FROM THE PUMP SPECIALISTS



- Lightweight Contractors' Pumps 25mm - 100mm (1" - 4") Petrol and Diesel Engines
- Heavy Duty Trash Range 50mm - 100mm (2" - 4") Petrol and Diesel Engines
- Submersibles from 400w to 1000w, DC and AC
- Drum Pumps — Oil Change Pumps — Garden Sprayers
- Sprinkler Pumps — PTO Pumps — Gear Pumps — Marine Pumps

TELEPHONE AUSTRALIA-WIDE FOR FULL BROCHURE

HANSON SYKES PUMPS PTY LIMITED



9 OAKDALE ROAD, GATESHEAD, NSW 2290
 (P.O. Box 264, BELMONT, NSW 2280)
 Head Office: Phone (049) 42 1350 Fax (049) 42 1303
 Factory: Phone (049) 43 6044 Fax (049) 43 6957

	Phone	Fax	Phone	Fax
Adelaide:	(03) 262 4279	(03) 349 4357	Newcastle:	(049) 43 3177 (049) 43 4571
Brisbane:	(07) 208 4555	(07) 208 9564	Perth:	(09) 459 2488 (09) 459 6115
Cairns:	(070) 511 596	(070) 511 579	Pt. Kembla:	(042) 95 1308 (042) 97 1520
Gold Coast:	(075) 93 4344	(075) 93 4135	R'hampton:	(079) 27 5933 (079) 22 2603
Melbourne:	(03) 547 3033	(03) 547 5689	Sydney:	(02) 666 6955 (02) 666 9112

Specialist service for the hire, rental & plumbing industry

In recognition of the special service needs of the Hire, Rental & Plumbing Industry, Flexible Pipe Cleaning Tools have extensively reorganised their Sales & Service Operations to meet these special requirements.

Accordingly, Flexible, who specialise solely in sewer & drain cleaning equipment (all brands and related products), are now able to offer a more intensified level of personalised service to their individual customers, with a view to achieving better returns for their clients.

Representatives now offer expert advice on how to extend equipment life, provide on the spot inspections of plant, cables & tools, and give instructions on operational, safety and preventative maintenance matters.

This service is entirely free.

Quick equipment repairs and after sales service is offered by Flexible,



A flexible pipe cleaning.

using only genuine replacement parts. Repairs are given special priorities and take precedence over normal work, in recognition of the need to have the equipment returned without delay.

Loss of rental income and customer dissatisfaction due to faulty equipment is substantial in some cases, and Flexible are looking to reduce this for their clients.

Brands such as Electric EEL, Rothenberger, Ridgid, Marco, General Wire, Burton, Flexible etc are serviced and repaired and equipment pick-up & delivery service can also be arranged at a nominal fee for those who do not have existing facilities.

Mobile phones have been installed to facilitate quick communications.

Flexible Representatives can now be contacted on the following mobile phones for instant response:

- VIC: Jim Farrugia
Mobile (018) 36 1524
- NSW: Tom Laidlaw
(018) 28 5034
(018) 28 5035
- QLD: Larry Harvey
(018) 74 2377

NEW OPTION
POLYETHYLENE
NON-RUST
BOWL

EASYMIX



Handyman
2.2 CU FT.

Compactor



Power Trowelling Machine



Tip up
3 CU FT.



3.5 CU FT.
2.2 CU FT.

Head office: 49 Felspar Street, Welshpool, WA. (09) 350 6255. Fax: 451 2312

VIC: (03) 338 5940

NSW: (02) 749 1222

NT: (089) 843 011

ACT: (062) 97 4924

QLD: (07) 848 8199

SA: (08) 261 3175



**It's
Party Time**

**Let's
Party**

Party Hire Index	Page
Bay Textiles	71
Bev Martin Textiles Pty Ltd	74
Hoecker Structures Pty Ltd	72
Hospitality Textiles	74
Johnson & Johnson Pty Ltd	69
Namco Furniture (colour advertisement)	33
Namco Furniture (story)	72
Quinn's Canvas Pty Ltd	73
Rooftop Balloons Pty Ltd	73
Sico South Pacific Ltd	70
S.I.G. Balloon Services	66
Trade Structures Pty Ltd	67
Vivacity Pty Ltd	69
Westminster China	74
Woodson Australia Pty Ltd	68

What's a party without balloons

Balloons are an area where enormous potential exists in the Party Hire business. If you are not in the business of selling balloons and hiring helium cylinders to your customers, consider these facts:

The total USA market for balloons is estimated at \$800 - \$1000 million per annum at retail and is still growing at 20% p.a.

The Australian balloon market is estimated at between \$15 - \$18 million.

The Australian balloon market has doubled in the past three (3) years but has the potential to double again before it catches up with the USA market.



Party Supplier is the fastest growing segment for Balloon Gas Sales in Victoria.

If somebody is going to the trouble of hiring party supplies, they are potential customers for helium filled balloons. After all, what's a party without balloons to create that special festive atmosphere?

The typical party that requires balloons hosts between 50-300 people, is an "important" such as 18th, 21st, 40th (garage backyard, etc.) or a hired hall where balloons are required to dress up the venue.

What do you need to be in the business? It is neither complicated or expensive, all that is required is:

Cylinders of Balloon Gas
Regulator

Balloons, Clips and
Ribbons

The total cost of stock would not exceed \$500.00.

A little product knowledge is also useful.

Balloon Gas is impure helium. Helium is a 'lighter than air' gas which is inert which means it is non-toxic and non-flammable.

It takes about one man/hour to inflate 100 balloons and these balloons will stay inflated 12 hours provided good quality balloons are used.

Good quality balloons are balloons that are at least 28cm in diameter, have no holes in them and provide a strong uniform colour.

Commonly, the balloons from supermarkets, etc. are 23cm or 25cm in diameter and are not really suitable. It is false economy to scrimp on balloons; the

difference between a good quality balloon and a poor quality balloon is no more than 5 cents. When 80 cents worth of helium is being used in each balloon, a good quality balloon provides value for money.

CIG produces Balloon Gas in three cylinder sizes:

D=100 28cm balloons

E=300 28cm balloons

G=600 28cm balloons

It is extremely important that the balloons are not overinflated as the stated number of balloons will not be realised



from a cylinder. This is best demonstrated by considering the formula for a volume of a sphere which states if you double the diameter the volume increases by 8 times.

If you are interested in entering the profitable and growing market, contact the following:

- **NSW - GLD**
Gary Liversedge, (02) 606 9377
 - **VIC - CIG Balloon Services**
George Eliou, (03) 487 8444
 - **QLD - CIG**
John King, (07) 275 0111
 - **SA - CIG**
Nick Dobson, (08) 354 9111
 - **WA - CIG**
Nigel Coote, (09) 381 0444
- or
- **CIG Balloon Services**
Allan Benson, (02) 796 2466.

RODER COVERS INDUSTRY

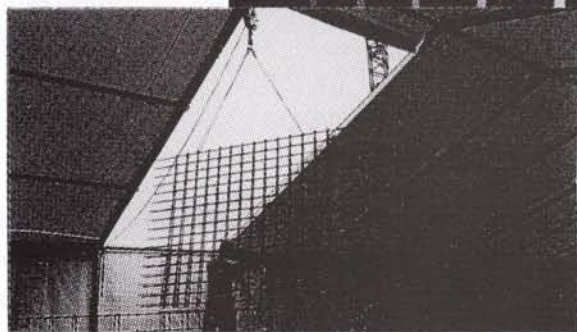
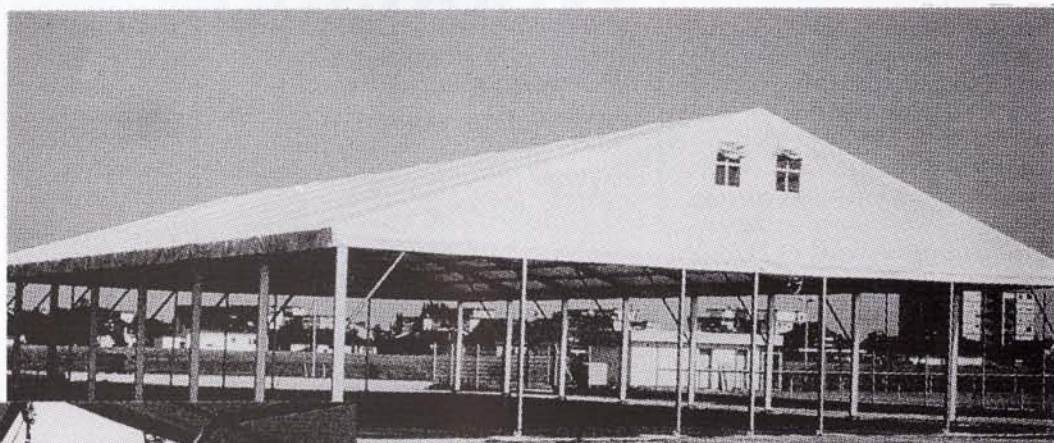

RODER TEMPORARY STRUCTURES

For the **Hirer** a new way
to serve the needs of **Industry and Construction**

Hire/Sub-hire/Purchase/Lease

Modular, free standing clear spans to 40M

Swiftly erected, sized to meet your requirements

German engineering with Australian installations expertise

Site Accommodation Cover. Covered Walkways. Equipment Hangars. Controlled environments for concrete pours and pipeworks. Freight & Produce storage. Isolation Storage of Dangerous Goods. On-site Commissioning of Large Equipment. Temporary Warehousing. Disaster Recovery.

Call us to discuss our **New Industrial Hire Plan.**

At **no capital outlay** the hirer can now cover the needs of Industry.

If you've got an application, we've got the solution.

Trade Structures Pty Ltd
(Inc. in NSW)
5/323 Clarendon Street
South Melbourne 3205
Telephone: (03) 696 6917
Facsimile: (03) 696 6954



**TRADE
STRUCTURES**

Woodson

synonymous with quality

Woodson Australia Pty Ltd is a company synonymous with quality and reliability and has maintained such standards over the past 30 years while producing a range of commercial catering equipment to meet the needs of the catering industry.

They now have an extensive range of pie and food warmers suitable for almost any situation within the catering industry.

Beginning with the draw type pie warmer, we have model no.'s 40DT and 80DT (40 and 80 pie capacity warmers) which are thermostatically controlled ensuring an even temperature is maintained throughout the unit. They have a stainless steel crumb tray and are finished in a grey hammertone enamel. Also available in this range is the model 83DT (40 pie capacity warmer) which has sliding steel doors and adjustable shelves. This model has been bought out to withstand the demands of the building industry but may also be used in situations where glass doors are likely to be damaged, such as the hire and rental market.

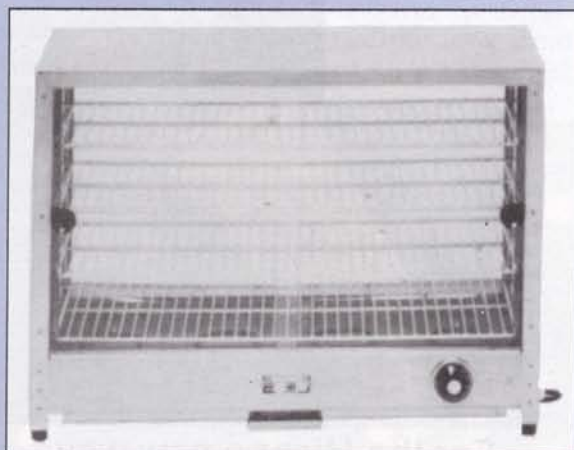

Pie Warmer model 810A.

Their top range of pie warmers boasts three different models 510 (50 pies) 810A (80 pies) and the 820 (100 pies). All three models are made from stainless steel with toughened glass front and back. They are designed both for safety and ease and allow visibility of your products for display purposes. These models are also thermostatically controlled and all glass and trays are removable for easy cleaning.

Woodson also produce a complete range of stainless steel hot water urns.

Manufactured with precision in mind they incorporate such features as:

- Boil dry protection
- Heat resistant lifting handles and lid knob
- Sight glass to indicate water level
- Pilot light to indicate power
- Simmerstat or thermostat boiling control

All your needs will be met with any one of the machines now available in the Woodson range of equipment.

MODELS AVAILABLE



LT/S-40

LT/S-30

LT/S-20

LT/S-10

The "Perfex Entertainer" roll

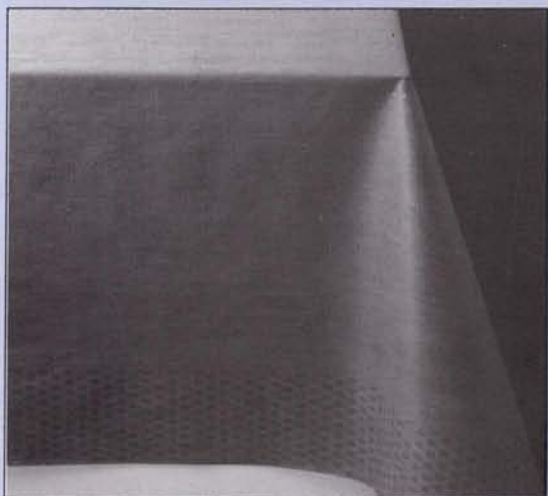

Drapes beautifully.

Johnson & Johnson is about to release a 15 metre Perfex "Entertainer" disposable tablecloth roll.

Designed specifically for the party/home entertaining market, it will be available from August.

Johnson & Johnson currently has 30 metre and 100 metre Perfex tablecloth rolls which have been selling successfully to professional caterers, clubs and hotels.

They represent very good value for the professional, but the purchase price is a bit much for the home entertainer who only wants to cover a few tables.

The new 15 metre Perfex "Entertainer" roll will sell at a price comparable to paper rolls and will give users the quality of Perfex tablecloth with sufficient coverage for up to four or five tables.

Perfex "Entertainer" rolls are in six colours: red, white, blue, light blue, grey and antique rose.

For those who haven't already used it, is a high-quality colourfast disposable fabric product, which drapes and feels like linen, and is used by many leading clubs and hotels.

The new Perfex "Entertainer" rolls will be available from all Johnson & Johnson distributors.

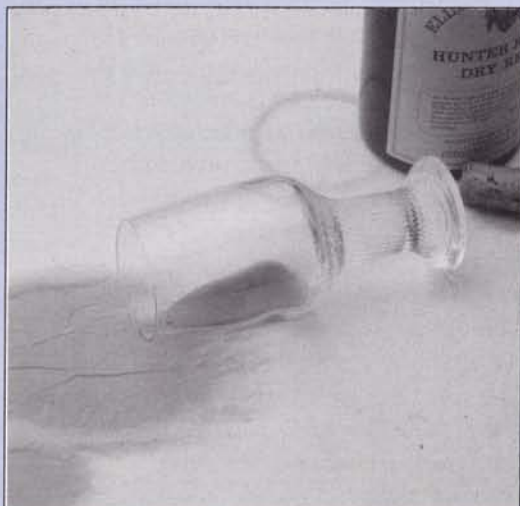

Colourfast and strong.

VIVACITY

(INTERNATIONAL) Pty. Ltd.

The Atmosphere Creators

★ SALES ★ HIRE ★ DESIGN

Ensure your next function is a success—are you having a:



★ PARTY ★ DISCO ★ 21st
★ B.B.Q. ★ PROMOTION
★ FILM ★ T.V.

Now Available: ★ Lasers ★ Disco Lite ★ Strobes ★ Mirror Balls
★ U.V.s ★ Bubble Machine ★ Smoke ★ Snow ★ Fog
★ Spider Web Machines ★ Lighted Dance Floors
★ Fire Works ★ Sound Systems

664 BRIDGE RD, RICHMOND, VIC. 3121. (P.O. BOX 44, G.P.O. RICHMOND, VIC. 3121.)
H.O. 390 ST. KILDA RD, ST. KILDA, VIC. 3182. TEL. (03) 534 5440. FAX (03) 525 3044

The atmosphere creators

Vivacity are known throughout Australia as the "Atmosphere Creators" as a result of their involvement with everything from parties, new product launches, gala balls, films to opening of new shopping complexes.

With over 20 years experience in every facet of entertainment, special effects, lighting and fireworks, Vivacity are the sole Australian distributors for many overseas manufacturers which include everything from rope-lights, mirror-balls, party/disco lights, fibre optic signs, fireworks, stage and theatrical special effects.

Supplying many hire companies throughout Australia with items hitherto thought to be unprocurable or unknown they have introduced not only very profitable hire items to the industry eg. Tech-Lites best known for their installations in Hyde Park, Sydney

and Collins Street, Melbourne. Through to easily installed party lights or alternatively Hi-Tech Lighting as seen and used at Moonba, Royal Melbourne Show, Dancing on the Street etc.

With the phenomenal growth of the DIY and Party Hire related industry in both domestic and commercial areas it is essential for the hire companies to not only be able to supply high profit return items but to also be able to advise and be aware of what is being utilised in today's market place by other companies.

Smoke machines • bubble machines • spider web machines • confetti canons • dry ice foggers • sound systems • disco systems • party packs • mirror-balls • pin spots • rope-lights • gyro balls • helicopters • light chaser controllers • snow machines • illuminated dance

floor • black lights • hawaian flares • tech (pea, pixie) or tiny lights by any other name - these are a few of the thousands of lines distributed by Vivacity, their guarantee is it's available we can supply, if not we'll manufacture it for you.

Vivacity are currently establishing a franchising network throughout Australia and will shortly have establishments in major cities in each state.

All enquiries will be welcomed.
Write to:

Vivacity Pty Ltd
P.O. Box 44, G.P.O.
Richmond, VIC. 3121
654 Bridge Road,
Richmond, VIC. 3121

or phone:
(03) 534 5440
Fax: (03) 525 3044

Portable dance floors

Back in the days of the grand ballroom, you had to predetermine the right size and location for the dance floor, and hope your needs wouldn't change. Then you had to live with it. But now that 80% of your public space business involves meeting rather than social events, you can't afford to have a permanent dance floor dictating your space's function. And meeting demand the accoustical control that a fully carpeted room provides.

The SICO Portable Dance Floor gives you the versatility you need, with no compromise in quality. Because SICO sets the standards worldwide. You'll have a beautiful, professional quality dance floor whenever and wherever you need it, quickly and easily.

You can multiply the flexibility of any size room, year after year, with



One person can transport and assemble a SICO Portable Dance Floor of any size. Structurally, it is the best portable dance floor made - designed to stand up to the accepted abuse portable equipment must take.

the SICO Portable Dance Floor. You'll maximize your profitability while minimizing labor, maintenance, storage and replacement costs.

A SICO Portable Dance Floor is easier to move than your tables and chairs, and just as flexible. Build a floor of any size, shape or location, as occasion demands. Meet day and evening needs, as well as unpredictable year-to-year dance trends. For instance, put a big floor in front of the stage or an intimate one to the side, then disassemble it quickly and easily for meetings.

One Person can transport and assemble a SICO Portable Dance Floor of any size. Structurally, it is the best portable dance floor made — designed to stand up to the accepted abuse portable equipment musttake.



'LUXURY LINER'

Another winning product from Baytex

For Silk Linings that perfectly complement the full range of Baytex Marquees as well as Structures by Roder and Hoeker. For Silk Linings to suit your individual requirements in a choice of colours and in Plain or Flame Retardent fabric contact:



Bay Textiles Ltd

P.O. Box 2571, Tauranga, NZ.
40 Mirrielees Road, Tauranga.
Phone (075) 78 8022, (075) 78 8921
Fax (075) 78 8978

AUSTRALIAN AGENT:

Mac II Enterprises Pty. Ltd.
4/46 Gilbert Park Drive,
Scoresby, 3179, Victoria
Phone: (03) 764 0033
Fax: (03) 763 4673

Namco Furniture continued research

Namco Furniture, a division of Email Furniture Limited, are heavily committed to the hospitality industry which, in turn, encompasses the hire and rental area.

A large range of quality all Australian made products have been developed and continuing research is enabling Namco to regularly introduce new items into the marketplace.

A newly designed stacking frame on the Aquarius and Strata polypropylene stacking chair allows easy storage and stacking of chairs also adding strength to the unit. Both ranges are available in 10 colours for the shells and 8 colours in the frames. The chairs have anti-static additives which reduce the dust attractive characteristic of polypropylene which, if untreated, may also accumulate an undesirable static charge.

Both the Aquarius and Strata chairs are available in round or square tube framing and the Strata is available with a sled base as an option.

Another member of the polypropylene chair family manufactured by Namco Furniture is the "Sitrite". This chair offers a revolutionary frame fixing method using injection moulded nylon clips instead of screw fixing, thus completely eliminating frame attachment problems.

The "Sitrite" is available as a four leg or sled base chair in a range of colours.

For style and durability Namco Furniture offers a large range of upholstered chairs which are also available as stacking chairs; included are the mini-stacker, Nordic, Fiesta, Cassia and Flair chairs.

Upholstered chairs come in a wide range of vinyl, synthetic or wool fabrics and frames are finished in epoxy powder paint, chrome or epoxy brass.

Known as the complete hospitality manufacturer, Namco Furniture also has numerous table styles including folding tables with sliding locating pin for positive lock action in their product range.

Namco Furniture are able to offer a complete range of Office and Contract

Furniture proudly designed and manufactured in Australia. The many designs which are modern as well as practical are easily integrated into any decor and come in an enormous range of fabrics and colours.

Products such as Filing Cabinets, Lockers, Shelving, Ergonomic Chairs, Desks are part of the office product range and tables, chairs, bar stools, reception furniture, church pews and theatre seating form a section of the range of hospitality products.

Reliability and efficiency are of paramount importance for Namco Furniture and coupled with research and development allows the company to satisfy demands without compromise which all adds up to Namco making your business look better.

For enquiries please contact -
Gerald Comer - Namco Furniture
152 Burwood Road,
Hawthorn Vic 3122
Phone (03) 819 4200
Fax (03) 819 6597

EXHIBITION PAVILIONS

Trade Shows • Exhibitions • Conventions

PARTY TENTS

Weddings • Birthdays • Celebrations

CLEAR SPAN WAREHOUSES

Storage • Construction • Factory Expansion

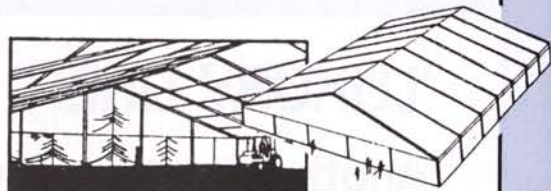

hoecker®

HOECKER STRUCTURES (AUSTRALIA) PTY. LTD.

SALES - LEASE - RENT

(03) 850 7833

FAX (03) 850 7053

8 Fairbank Crescent, Lower Templestowe

- From 6 metre to 70 metre wide • Up to 200 metre long • Direct from manufacturer
- Shelter and protection for any industrial purpose or event is only hours away with HOECKER

Up, up... and away

Bright bold colours of red, yellow, blue and pink are usually associated with balloons. Seen at children's birthday parties, celebrations and amusement parks, these fun colourful objects are really just decoration, or are they?

The balloon has taken on a new usage within the sign industry, for one particular Sydney based company, the new development has meant a huge business boom.

The Rooftop Balloon company originated from a company in San Diego, California, which specialised in inflatable tube signs and roof top balloon signage. The company is only newly established in Sydney, but their signs are already being seen right across Australia. "Tube signs are a new innovative type of sign, which can be both temporary or long term signage," said Managing Director, Robert Waddell.

Tube signs are especially convenient for food and grocery stores, which are opening or offering specials and attractions, "Tube signs and banners can be used for exhibitions, forthcoming events, grand openings and half price sales. They really do attract attention, so in result, work very effectively.

We find that the nightclub, real estate, and retail people holding sales events use our type of signage a lot," he said. There are various sizes available from three feet high and 27 feet in length to six feet high and 54 feet in length. The tube signs illuminate at night, which cuts down largely on electrical costs, the most popular colours being yellow and white. The banners are made from reinforced vinyl, which is manufactured overseas.

"Many large companies use the inflatable signs for promotions and openings, especially the inflatable replica signs. Coca Cola had forty, eight foot coke cans made," said Robert.

The new chocolate manufacturer, Milka, has had several huge inflatable Milka cows made to be distributed throughout shopping centres and supermarkets such as the Westfield shopping town in Chatswood and Melbourne.

"The product replica market is absolutely booming, they are fun and are very effective in promoting the product. Other replicas we have done include Sorbent toilet rolls, Pal Dogfood cans, and most recently three Icee Cups for the Royal Easter Show," he said.

Rooftop balloons is the other type of sign manufacturing done, the balloons are used for major grand openings and exhibitions. "Food Plus, Mobil Oil, Shell and Video Show Stopper are just some of the customers.

"The balloons are tethered on the roof of the building by two professionals from the team, air compressors are used, but not hot air, just normal room temperature air, and all the artwork is done within the factory," he said.

The balloons reach a height of 35ft, the banner area measures 12ft tall and 20ft long, and takes approximately 15 minutes to inflate. It is illuminated at night by electrical lighting from the inside.

When asked if the company would expand, Robert had a very definite yes, "We will be establishing ourselves in a new factory very soon, we need the storage space, the balloons take up a lot of room" he said.

*Tube signs are
especially convenient
For food and grocery
stores, which are
opening or offering
specials and attractions...
they really do attract
attention*

QUIN'S MARQUEES



Marquees manufactured to your requirements.

All sizes in either Frame Style or Peg & Pole Style using Australian made PVC synthetic or canvas material.

For further information contact:-

Dave Lawrie or Ross Lucas
at

Quin's Canvas Goods Pty Ltd

10 Kyle Place Pt, Adelaide, S.A. 5015
Phone: (08) 47 1489 - Fax: (08) 47 8622

The Westminster Company

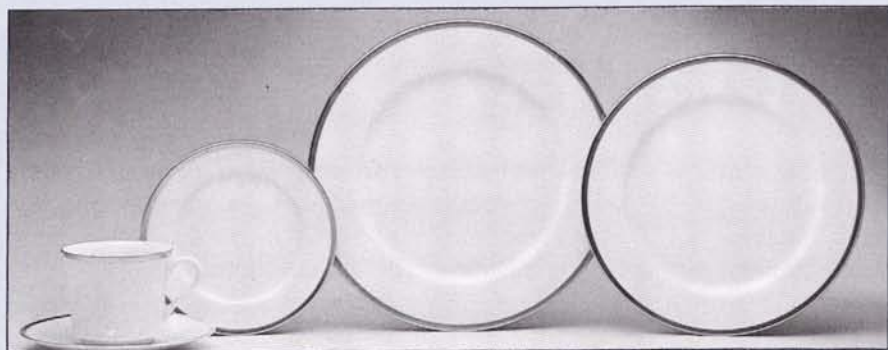

With one small kiln and a staff of four: Westminster produced its first decorated china in 1954. Two years later, the company attracted a number of employees from the United Kingdom skilled in the field of ceramic printing in 1957, they were joined by experts from Italy. Within a year Westminster had its first tunnel kiln brought out from Germany. By 1960 the factory employed a staff of 24 and in 1962, established a ceramic transfer printing department. 1963 saw the development of the first product range for the catering industry and kiln capacity was increased in 1968. It was 1975 when the Westminster company moved to larger premises, taking over a two acre site and a 330000 square foot factory and office complex. Four years later the first computer was installed, and in another 12 months, semi automatic lining equipment was also installed.

The plant and equipment continued to

be upgraded through the 80's and by 1988 Westminster had constructed a high rise warehouse of 22000 square feet and installed the latest in computer technology. A family owned company, Westminster is headed by William Rogers, Managing Director. His son Clyde Rogers, now 34, has been with the company for 12 years.

Westminster Catering Ware

Westminster Catering Ware is a range of medium weight hotelware designed especially to suit middle and upmarket restaurants, hotels and catering establishments.

With Westminster's unique facilities, we can offer you this range in plain white, with precious metal decoration, or decorated to suit your own requirements.

Westminster guarantee to replace your catering ware in all shapes and decorations for a minimum period of ten years.

Westminster is sold through a network of distributing conveniently located around Australia, supported by interstate offices and sales agents.

You'll find Westminster in hundreds, of restaurants, hotels, motels, and many

food service areas across the country.

Enhance your reputation with fine quality China

Westminster China is specially designed to withstand the rigours of catering use, yet possesses the look of the finest domestic tableware. Let Westminster China help you create an atmosphere of quality and elegance.

Three shapes are available, each produced in an extensive range of items to meet your every catering need. Choose from a wide variety of in-stock decorations, current decorations or special designs.

In stock Decorations

Plain White, Gold Edge and Platinum Edge are carried in stock in depth at our Sandringham factory. In addition most items are stocked by our Australian regional (distributors).

Special Decorations

If you are considering a custom design, ask the factory or your nearest distributor for details of our special design service. Minimum quantity orders for your special logo or badge are surprisingly low - 750 pieces in total. More complex border decorations require a minimum order of 2000 pieces. Usually delivery can be arranged within 6 weeks of approval of artwork.

Westminster's regional distributors are strategically placed throughout Australia and New Zealand. Should you require further information or the address of your nearest distributor please contact our factory in Sandringham or our interstate Sales Offices.

Visa - for the best of everything in beauty and performance

Only Visa napery fabrics offer you consistent colors...superb stain release and brightness...freedom from unpleasant odors...outstanding absorbency...superior durability.

Excellent color retention...Visa napery fabric colors stay true, unlike all-cotton and poly/cotton blends. Even after 100 washings they still look bright and new. For you, this means consistent napery colors that match time after time.

Stain release and brightness... Visa napery fabrics have an extra-ordinary ability to release stains, soil and odors for the life of the fabric. This means clean, fresh-smelling napery after every

A sample of a Visa product.



laundering. Visa napery also resists soil redeposition for whiter whites and brighter colors.

Outstanding absorbency...Visa napery is able to soak up spills quickly for the life of the fabric.

Superior durability...Visa napery fabrics contain special yarns which give them a natural fiber feel. These continuous filament yarns give you freedom from pilling and fiber loss. Unlike cottons and blends which lose fibers wash after wash, Visa fabrics keep their original weight and body throughout their normal life.

Yanmar releases new loaders

Yanmar Construction Machinery Company of Osaka Japan has announced the release of a new range of hydrostatic Four Wheel Drive Loaders suitable for all terrain applications as a versatile loader for lifting, dumping, carrying and levelling at construction sites, roadworks farms and parks.

The first two models of the new range are known as the V3 and V4 with the bucket capacities of .4m³ and .5m³ respectively.

The Yanmar Automatic Hydrostatic Transmission eliminates cumbersome clutch control and assures simple and smooth operation, just like an automobile. Travel speed can be infinitely controlled by the accelerator foot pedal. Single loader - control lever, feather-touch mono lever for Forward/Reverse and High/Low speed shift. The fully hydraulic power steering unit minimises operator fatigue with optimum cycle speed.

Superior manoeuvrability comes easy with a compact body with large frame articulation (40° on both sides) which

One of Yanmar's new loaders.



enables easy access in confined working conditions. The V3 and V4 excel in productivity, due to a powerful bucket digging force of 2,270kg (V3) and 2,780kg (V4). A large dumping height at 2,175mm (V3) and 2,445mm (V4) and with ground clearances up to 270mm, the Yanmar V3 and V4 are performance articulated wheel loaders.

These machines are so simple and smooth to operate that even a novice operator would become proficient after

one days trial with a Yanmar V3 or V4 loader.

Serviceability and ease of maintenance is also assured through a reclining type bonnet which allows total access to every corner of the engine compartment.

Technical Data brochures on the Yanmar V3 or V4 loader are available from Tutts branches at Brisbane, Sydney, Melbourne, Hobart, Adelaide and Perth.

PAT 101 answers needs

Megger instruments is introducing the PAT101 at the top of its range of portable appliance testers and government regulations are extended - and employers scramble to react.

Sales of PATs are already growing significantly in anticipation of the April 1 extension of the Electricity at work regulations (1989) into all workplaces.

The PAT 101 has been designed to provide a higher level of appliance testing to satisfy the operational needs of electrical equipment manufacturers, repairers, and hire companies, as well as larger employers and contractors; all companies now require more periodic checks to ensure the safety of portable electrical appliances in the workplace.

New features of the PAT101 include:



The PAT101.

two earth bond tests, one for heavy duty (25A) equipment and the other for equipment supplied by light duty (4A) cables; and two levels of low voltage flash testing for both earthed and double insulated appliances.

The versatile instrument also allows earth leakage checking - an aid to diagnosing RCD tripping problems, insulation testing and operational VA testing.

The tests are selected by a single rotary switch and executed by pressing a 'Test' button.

The appliance to be tested is simply plugged into the standard sockets on the front panel. Testing is via the sockets, with the support of a clip or probe leads provided.

An analogue meter gives both an at-a-glance indication of appliance status as well as more detailed readings for thorough performance analysis and logging of results - a requirement under the Health and Safety at Work Act.

The mains-powered PAT101 - itself made safer for the user through the incorporation of a resettable circuit breaker - is capable of carrying out all electrical safety tests on a comprehensive range of equipment. It includes industrial and domestic appliances, business machines, power tools and audio equipment.

Marketed by Nilsen Instruments Pty Ltd, P.O. box 930, Carlton 3053 VIC. Tel: (03) 347 9166, Fax: (03) 347 3919.

ON-SITE TOILETS



**SINGLE
AND
DOUBLE
UNITS**

Mounted on a heavy duty galvanised trailer for mobility. Time saving exercise when two or more units are required on-site.

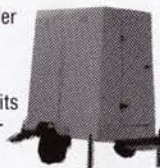

ON-SITE BORE HOLE TOILETS

This one has been specifically designed to suit the outlying areas where sewer connections or regular emptying of effluent tanks is impossible or impractical.

FEATURES ARE:

- Units are fully moulded in fibreglass.
- Exterior is gelcoated and the interior is flow coated.
- Low maintenance and easy cleaning.
- Fibreglass doors have stiffening ribs with aluminium plating moulded in.
- Doors are fitted with galvanised self closing hinges and locking devices.
- Fly screened vents are fitted for ventilation and insect/weather proofing.
- Skylight in roof provides natural Lighting.
- Hand basin is fitted, complete with waste and drain plug.
- Fibreglass units are strong, durable and aid hygiene.
- Units are light, easily transported and installed on-site.

OTHER MODELS AVAILABLE:

- ★ Standard Open Closet.
- ★ Sewer Connecting Toilet.
- ★ Internal Components Complete.
- ★ Completely Fibreglass Moulded Toilet or Heavy Duty Galvanised Steel Frame with Colourbond Sheeting.
- ★ Fibreglass Showers.

**NEW FROM
FORM-IT
FIBREGLASS**

Our factory is at:
1 JOHNSON ROAD, WYONG, NSW 2258
PHONE: (043) 53 1355
FAX: (043) 51 2421

Expansion programme underway for Park Hire

Park Hire, a leading hire equipment company in Nowra, begins an extensive expansion programme with delivery of Instant Zip-Up access equipment. Eventually they will have a large fleet of Instant Zip-Up equipment and will become the only company in the area able to solve the varied access problems of their clients.

Park Hire is in its 8th year of operation in Nowra and during that time have grown to become one of the largest hire equipment companies on the South Coast. An achievement gained by providing reliable equipment and a high level of service and support. All Park Hire equipment is regularly maintained to prevent breakdowns and to ensure that all safety requirements are met. Park Hire can confidently claim to be the number one supplier in the area - a position they will continue to maintain by providing clients with the best equipment available. Park Hire also carry a comprehensive range of Instant Scaffolds scaffolding, both fixed and mobile - equipment in which Instant Scaffolds have been market leaders for a number of years.

Today Park Hire have a staff of 15 responsible for servicing their 600 clients. Business continues to increase resulting in the need to expand both their premises and their product range. Plans for larger premises in Nowra are underway with the possibility of fully equipped branches being located in outlying areas in the near future.

The Instant Zip-Up access equipment range was chosen over those offered by other suppliers due to their proven reliability, safety aspects and the fact that they are easy to service and have the lowest maintenance record in Australia. The company that supplied the Instant Zip-Up range is Instant Scaffolds, of which Instant Zip-Up is the mechanical equipment division. They have offices throughout Australia and a range of equipment second to none.

Mr Jim Maxwell, Branch Manager for Park Hire, said, "The service and



The SL26 Scissor Lift from Instant Scaffolds.

follow up provided by Instant Scaffolds plus the outstanding features of the Instant Zip-Up range made our choice a simple one.

"We offer only the best equipment available on the market and believe this range meets all our requirements while providing our clients with the quality and level of safety they expect from Park Hire."

The Instant Zip-Up aerial work platform range includes both the scissor and z-type lifting mechanisms and are available in various heights to allow every access problem to be overcome. Their manoeuvrability is outstanding with a tight turning circle of 90 degrees and their slim line construction means they are able to access some tight spots. The scissor lift models include the XL19C, XL19CW and XL24 and the Z-type models include the SL20 and the SL26 - the various numbers denoting platform height.

Instant Scaffolds will be demonstrating the Instant Zip-Up range at the Future Directions 19th International Hire Convention and Equipment Exhibition to be held in Adelaide on 10 to 14 September at the Adelaide Convention Centre. Visit their stand to obtain more information and to have equipment demonstrated at any time during the show period.

Roofing safety attracts new interest in fall prevention



Perimeter Guardrail System.

A Melbourne roofing plumber and draftsman have developed a steel safety rail which they claim will reduce the number of deaths and injuries resulting from falls on construction sites.

The patented system uses steel clamps and square section steel legs and rails to provide a strong safety barrier for workers employed on construction site roofs.

While working on a construction site

Mr. Con Griek and Tony Mitchison realised an improved safety system was required if the number of falls from buildings were to be reduced.

They set about developing a guard rail that could be attached directly to most roofs either on the roof perimeter or the roof decking.

"The Guardrail Systems barrier not only meets the Victorian Code of Practice covering roof safety but also establishes a benchmark for building safety which is being adopted in other states," said Barry Stokes of Guardrail Systems.

The free standing system has been designed for use on buildings prior to the

Con-Rain System.



Deck Guard Rail System

roof and wall cladding being fixed in place.

The system is also an effective safety barrier for maintenance work carried out near the edge of a roof.

The clamps used can attach to either 'C' or 'Z' purlins without the use of tools.

A scissor lift or similar work platform is all that is required to erect the system.

The Guardrail steel safety rail provides a strong barrier for workers employed on construction site roofs which, the designers claim, will reduce the number of deaths and injuries in preventing falls from roofs.

WE'RE MAKING TRAKS THAT HELP YOU MAKE MONEY

We're making traks in the materials handling equipment market.

There are five Sky Trak® rough terrain forklifts with lift capacities to 9,000 lbs. and reach to 37 feet 6 inches.

New Heavy Duty Scat Trak skid steer loaders are engineered exclusively for the construction industry.

Call us today. Prompt service is our strength. We are all part of the Trak Team. We'll recommend the right Trak to help you make money.

D-986-2



KOEHRING
CONSTRUCTION
EQUIPMENT
Products of
TTRAK
INTERNATIONAL

INTRAC (SALES) PTY LTD

WE'RE MAKING
TRAKS
THAT HELP YOU MAKE MONEY

256 Princes Highway, Dandenong, Vic 3175. Ph: (03) 791 3300. Fax (03) 791 8398

NSW: Cess Hill Industries Pty Ltd (047) 35 4333
Qld: Wiltrac Pty Ltd (07) 375 5988

WA/NT: CJD Equipment Pty Ltd (09) 277 2011
SA: AJC Sales & Service Pty Ltd (08) 347 1498

High performance electric forklift from Clark

Clark Equipment Australia Limited, is now manufacturing the latest models of the German designed TM Series Electric Forklift.

Capacities range from 1.0 to 1.6 tonne at 600mm load centres.

A choice of pneumatic, puncture proof or cushion tyres allows the TM to be used in a variety of warehousing, factory or yard applications.

The three wheel configuration, provides extremely good manoeuvrability in tight working areas and the very compact design is suitable for narrow aisle and limited overhead clearance situations.

The new models also feature a tilting steering column, which can be easily adjusted by the operator to his requirements. A battery discharge indicator shows the state of battery charge and will automatically intercept the lift function in the event of low battery level. This feature provides protection to the units



The latest model from Clark: lots of new features.

electrical system, a problem often encountered with electric vehicles being operated with heavily discharged batteries. Power steering is supplied as standard equipment.

Users can choose between a variety of two and three stage high visibility uprights offering lift heights of up to 6.5 metres.

Hydraulically operated disc brakes are internally mounted for protection, yet readily accessible for inspection and maintenance.

A parking brake is mechanically operated and disconnects power to the drive motor when applied.

Hydraulic function control levers are conveniently accessible and directly linked to sensitive, precision control valves.

Businesses, looking for an electric forklift truck to work in the beverage and food warehousing industries or in retailing or freight forwarding could not do better than consider the Clark TM Series.

Please contact your local Clark Dealer for more information or alternatively contact:

Clark Equipment Australia Ltd.,
30 Salisbury Road,
Hornsby, NSW 2077.
Phone (02) 477-8444
Fax (02) 476-2241.

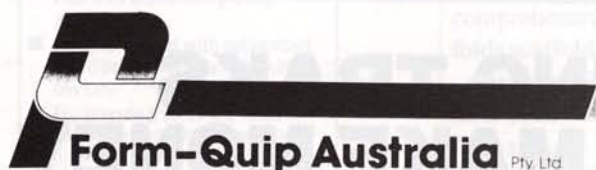

**Hire • Sale
Service • Erection**

Scaffolding

Modular Systems
Tube & Fitting
Safety Screens & Fencing
Hoardings

Proudly Australian
Form-Quip Australia Pty Ltd
2 Ashford Ave., Milperra 2214

792 1711

**The Simple System
that Savages your
bookkeeping!**

OMNIHIRE

OMNIHIRE is a Software Package with an easy to understood MENU System and on screen INSTRUCTIONS in plain english, you can learn in hours.

OMNIHIRE can prepare reports showing location and hirer of all equipment.
OMNIHIRE can enter your hires, sales, returns, account payments, and repair costs.
OMNIHIRE can prepare invoices, delivery dockets, and monthly statements.
OMNIHIRE can produce a comprehensive analysis of all daily and/or weekly takings.
OMNIHIRE can change all hire rates or state rates at a push of a button.

Now available in Victoria and throughout Eastern Australia - Contact: DENIS VAUGHAN
MID-COMP PTY/LTD
125 BRIDGE STREET
PORT MELBOURNE
VICTORIA 3207
PH (03) 644 3883

mid-comp

MID-RANGE COMPUTER SERVICES

Aggreko in new power play

Aggreko Generator Rentals, the world's largest and best-known generator rental company, has continued its quiet 'march' around Australia by establishing a base in Sydney. It has acquired Generator Rentals which, for many years, has been Sydney's biggest supplier of temporary and emergency power.

The outlet can now offer the largest and widest range of generation equipment for rent in Australia, including Aggreko's renowned Hushpower 'silenced' generators from 15KVA to 1,850KVA, and load banks, resistive and reactive, from 200kw to 1.2 mw.

The name Aggreko - based upon the Dutch word, aggregate, meaning generator - is part of the vocabulary of the industrial world.

The company started off serving shipping and off-shore industries from its factories near Rotterdam in the Netherlands and at Dumbarton on Scotland's Clyde Estuary. By 1985, it had grown to serve much of Western Europe, with fac-

ories or major depots in France, Norway and the German Federal Republic, as well as its chain of UK and Dutch bases.

It then joined the Christian Salvesen PLC Group, a highly successful multinational organisation, enabling Aggreko to renew or modernise almost all of its property and plant and expand still further across Western Europe. Its power hire fleet now has bases not only in Europe, but also in the US and Australasia.

Aggreko's world-wide success is attributed to its extensive range of equipment, experience in choosing the best equipment, and non-stop service.

The new Hushpower range of 'silenced' generators provide a quieter, safer working environment. They can be paralleled, or containerised for shipping and other uses.

Sound levels from the Hushpower generators are as low as 70 dBA, and it's possible to hold a conversation normally while standing alongside one of these units.

The generators are encased in acoustic canopies made of 10-gauge fully-welded

steel, and are fitted with an integrated and protected exhaust system with a spark arrester residential silencer. They have generous fuel storage tanks, which allow up to 20 hours running.

Another feature is their high quality instrument for displaying frequency (Hz), phase voltage (V) and phase load (A), and a stainless steel control panel on most models.

Safety is enhanced by simple start-stop controls and a full load circuit breaker, with overload and short-circuit protection. There is also automatic protection on overspeed, high water temperature and low lube-oil pressure.

Aggreko Generator Rentals now has branches in Sydney and Perth, Newcastle, Kalgoorlie, Adelaide, Brisbane, Darwin, Hobart and Launceston with Head Office in Melbourne and supplies power 24 hours a day 7 days a week.

Portable power users in industries such as mining, shipping, construction and manufacturing Australia wide are now benefiting from Aggreko's quality equipment.



POWER CUTTERS

MODEL 264TTA SPECIFICATIONS

Capacity — 59cc	Reversible 12" Cutting Arm
Chrome Bore	Full Anti-Vibration
Triple Air Filtration	Roller Support

Oleo-Mac offers the hire industry a well priced reliable power product, with excellent spare parts back-up and service

12 MONTH WARRANTY

National Distributor:

CRANFORD PRODUCTS

39 Parkhurst Drive, Knoxfield 3180

For more information please phone: (03) 800 1711

or Toll Free 008 338 027

Omnihire - computer software for hire companies

A complete administration and management system for hire companies in one easy to use package. Written in non computer language, this programme can be installed and fully understood in a matter of hours. Designed in conjunction with one of Australia's largest hire companies, this programme was written by Australians specifically for Australian businesses.

Some of the outstanding features of Omnihire are:

- Reports showing location and hirer of all equipment.
- An instant list of all equipment available for hire.
- A report showing all long term hire contracts and return dates.
- Frequency of equipment use by industry, company, area, etc.
- Complete record of all consumable stocks.

- An option to write off unpaid accounts.
- List all outstanding accounts.
- Prepare invoices and monthly statements.
- List all repairs and maintenance costs.
- List last five users of any piece of equipment.
- Change all hire rates or state tax rates at the push of a button.
- Comprehensive analysis of all daily, or weekly takings.

Omnihire will allow hire companies to make informed management decisions and will quickly pay for itself by reducing equipment losses, keeping track of bad debts, providing better customer service, saving hours on laborious paperwork, and providing fast information on equipment costs and repairs.

At last, here is a comprehensive

programme for the hire industry which solves administration and running problems, is very easy to use, and all at a sensible price tag.

Demonstration disks are available free of charge by calling:



Suite 2, York House,
19 York Street, Subiaco 6008
P.O. Box 1089, West Perth, WA
Tel: (09) 381 7411 or

mid-comp
MID-RANGE COMPUTER SERVICES

125 Bridge Street,
Port Melbourne, Victoria 3207
Tel: (03) 644 3883

"THE PORTABLE TOILET ALL OTHER PORTABLE TOILETS ARE JUDGED BY."

Gordon Esden, Rent-A-Loo.

It's called Poly-San. The ultimate portable toilet, made from strong, resilient and durable polyethylene. Poly-San has a proven track record of more than 20 years in the United States and here in Australia. The modular circular design creates a strong yet easily-repaired cabana, with a 'clamshell' door reinforced with tubular steel. The Poly-San can be fitted with open closet or freshwater flush and the interior is streamlined for easy cleaning. Poly-San is available for sale from the Australian distributors, Prestige Portables, in a range of exclusive corporate colours. For a detailed brochure, please phone Prestige Portables on (02) 688 2688.

Poly-San



Do the right thing. Your customers continually ask for

Gerni.

Have you got genuine Gerni for hire?

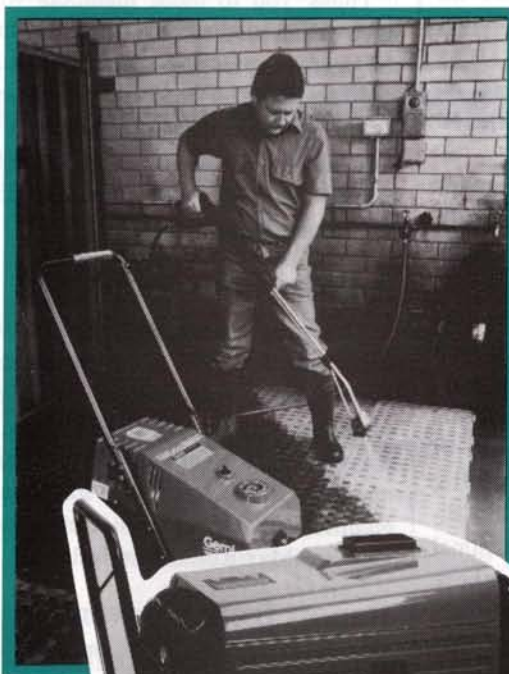

Your customers want Gerni because they know they get genuine cleaning performance... Turbo Laser performance, exclusive to Gerni, doubles the cleaning power.

Hire companies who insist on genuine Gerni know they get guaranteed quality and long life.

Gerni delivers all this and a whole lot more of what you expect from a high pressure water cleaner, like reliable service support, genuine spare parts back-up and expert advice based on many years involved in servicing the hire industry. Gerni — Australia's clean leader.

For sales and service, genuine spare parts, accessories and detergents, contact:

VIKING EQUIPMENT PTY. LIMITED

NSW 3 Kelso Crescent
Moorebank 2170
Phone (02) 602 3666

VIC 218 Princes Highway
Dandenong 3175
Phone (03) 793 1892

QLD 754 Beaudesert Road
Coopers Plains 4105
Phone (07) 275 1388

*Or call us on 008 112 428 from
anywhere in Australia for the cost
of a local call.*

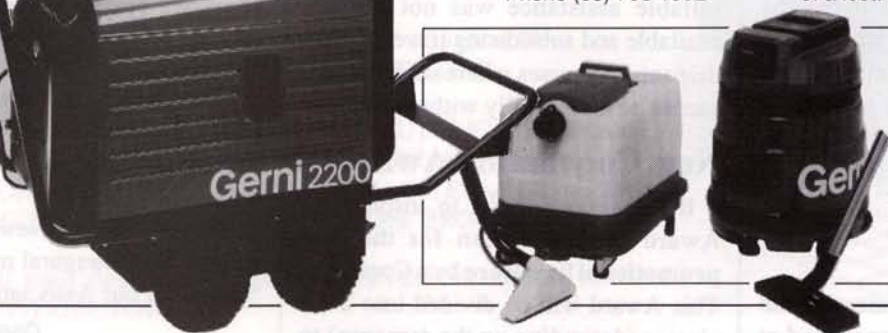

Also available from Gerni...

- Gerni Extra — high quality carpet/upholstery fabric cleaner
- Gerni Vac wet and dry super robust commercial vacuum cleaner

New Zealand Report



Directors Meeting

The Directors recently held an extended meeting at President Trevor Tuffnell's holiday residence in the Pelorus Sound, (at the top of the South Island) Our "Floating Director" for the meeting became literally that on the Saturday whilst part of the meeting was held on the way up the Sounds to the main Fishing areas where the Directors spent the remainder of the day enticing local cod and other species to "take the bait".

A relaxing and rewarding day saw sufficient fish being caught for meals for the remainder of the weekend as well as a supply being taken home by each Director. Meetings held both prior to and following the fishing part of the trip enabled the usual amount of business to be conducted.

Promotion of Industry

The Directors on behalf of the Industry are always on the look-out for ways to promote the Industry. In addition to the reprinting of the Membership Directory prior to Convention, the Directors agreed to the purchase of a collapsible display stand for use at Trade Displays and which also will be available for use by Members for local shows. The purchase of jackets featuring the Association logo: the production of promotional stickers for use by Members on their mailing envelopes and the printing of jotter pads highlighting individual members names and other relevant details are all currently underway.

Training

At the recent Directors meeting the subject of Training was considered at



some length including the provision of resources for zones to use in Training Seminars conducted by them. It is pleasing to see Zones continue to arrange Training Seminars in conjunction with their Zone meetings.

Previously persons attending training courses were only provided with certificates at the conclusion of a course (which were made up of a series of modules). It has been agreed that certificates recognising attendance at each Module will be provided for participants from now on. The Directors have also considered the best use of funds available from the Training Foundation and future uses could include assistance for the professional writing of course material where suitable assistance was not already available and subsidising travel by participants to courses where such courses cannot be held locally within a Zone.

New Convention Award

It has been decided to institute an Award at Convention for the **best promotional literature** by a Company. This Award will be divided into 2 - 3 classes (depending on the response) to

enable Companies of similar sizes to compete on equal terms.

Legislation

Members have been circulated with a summary of the recent changes in Transport Legislation and the Association has also been accepted (on behalf of both itself and New Zealand Contractors Federation) as a member of the working party considering a Code of Practice for Towing Trailers.

1991 Pacific Convention

Thank you to those members who have returned the form from the last magazine expressing their interest in this event. A detailed programme will be forwarded to these members just as soon as it is finalised and will also be printed in the October edition of Hire and Rental Industry Quarterly.

Annual Convention

The programme and registration form for the 1991 Convention and Equipment Exhibition in New Plymouth August 14 - 16 has been distributed to all Members and to several members in Australia who have made enquiries. A report from Convention Director Max Rutherford follows.

Report from Convention Director - Max Rutherford

Most details are now finalised for what should be a very enjoyable 13th Annual Get together - back where it all started 14 years ago.

Gordon Dale of New Plymouth organised that inaugural meeting and the "oldies" of our Association will have a

Continued Page 83

New Zealand Report (continued)

From Page 82

chance to meet Gordon again as he is involved in the organisation this year and will be attending Convention.

The Coach Tour on Tuesday will visit venues of interest to Delegates and Wives/partners as it will be a mixture of scenic sights, Hire Yards, Think Big projects and a mystery venue which will be revealed on the coach.

Entertainment the first evening will appeal to all, as the Gaslight Variety Show which has been running for over ten successful years in New Plymouth, features an excellent cast and will be accompanied by an "Olde English Style Meal". It is not intended on this night, nor on the Wednesday evening to be late finishing.

Our speakers on Wednesday morning come to us with very good recommendations, and Tony Ward in particular has a subject dear to his heart! You will definitely learn more about running your business smoothly from

these experienced speakers.

Entertainment on this evening is by way of a Fund Raising project for the Training Foundation. Food will be supplied in a rather different manner to add to the Casino atmosphere.

Trade Suppliers are already booking space at this early time which augurs well for a good display. Interest is higher than it has been for the last few years and once again our friends are coming forward with sponsorship in the form of cash, and goods for distribution and for the Casino Auction.

Thursday morning is the important Association time and this year will feature an allotted time for Zone meetings and for the first time, a chance for other Trade Exhibitors/Associate members to meet and discuss their requirements at future conventions etc.

After the second Exhibition time on the Thursday afternoon, the final eve-

ning features top entertainment in the person of Robin Tuakere (Taranaki's answer to Howard Morrison). Robin has performed in New Zealand, Australia and Asia, and has agreed to come out of semi-retirement to perform for us. He will be backed by Freeways Band who were the only non-Auckland band to play at the Commonwealth Games. They are all "our age group" and play music suitable for a wide age range.

All in all it's going to be a great Convention so I hope you all plan now to be present and participate. With New Plymouth being fairly central to the majority of the membership, and Suppliers, Transport costs should be manageable, and with modest accommodation rates (yet high class) along with a reasonable registration fee there is no doubt it will be value for money.

I hope to see you all there.

MIGOMAG

It Must Be A Migomag

THE BETTER ALTERNATIVE

**60%
DUTY
CYCLE**

- **BETTER PERFORMANCE** — MIGOMAG MIG WELDERS are POWERFUL and DEPENDABLE so you can meet your WELDING schedules FAST.
- **BETTER QUALITY:** Engineered for **LONGLIFE**. Backed by a **3 YEAR WARRANTY**.
- **BETTER VALUE:** An INVESTMENT which will PROTECT you from COSTLY DOWNTIME.



WHETHER YOU NEED A MIG WELDER FOR AUTOMOTIVE SMASH REPAIRS, METAL FABRICATION, MANUFACTURE, RURAL USE, CONSTRUCTION, STRUCTURAL STEEL OR MAINTENANCE, THERE IS A MIGOMAG MODEL FOR YOU TO CHOOSE FROM.

ACT NOW, call your nearest MIGOMAG BRANCH for details of your LOCAL DISTRIBUTOR.

Telephone: SYDNEY: (02) 604 8522, NEWCASTLE: (049) 69 5974, MELBOURNE: (03) 336 1960, PERTH: (09) 451 8566



MIGOMAG

Metalert user survey proves many have been winners!

As part of its on-going product development, *Metalert* recently concluded a detailed survey of many of its current users. A very high number of those who were polled (25%), replied and were included in a draw for a free unit.

Although the draw allowed only one winner, the survey statistics show that there have been many winners with *Metalert*! An extraordinary 46% of users reported that one or more "saves" had been prompted by *Metalert* monitoring, mostly Transmissions and Differentials. Clearly, *Metalert* has been very reliable at detecting excessive wear or damage in a variety of oil lubricated housings.

As expected, 70% of users gave the reasons for acquiring *Metalert* to be the

monitoring of wear, avoiding breakdown, and the saving of time and money. The most notable *Metalert* features for 64% of users are the detection and confining of failure before serious damage develops, and the peace of mind/sense of security in operating their machinery.

The survey sought from users, suggestions for improvements. Thankfully, most of the suggestions had already been incorporated in their latest design as part of on-going developments.

The level of customer satisfaction with *Metalert* was excellent with 94% indicating they would purchase another *Metalert* system. The average number of *Metalert* units owned by the respondents was 1.34.

Those relative few who indicated

some dissatisfaction with their system have been approached and their problems isolated to incorrect installation or incomplete instructions etc.

All survey responses are to be retained for future reference and a set has also been supplied to the Queensland Agricultural College at Gatton for independent analysis and review.

As hard times puts more pressure on improved productivity and reliability for machinery, a product like *Metalert* can make the right difference to the bottom line.

Dealer or User enquiries will be welcomed by:

Metalert Manufacturing & Sales Pty Ltd
on (07) 395 7400.

RELIABLE, AND COMPACT, AND POWERFUL... CASH 'N' CARRY TO BOOT.



HIRETECH WALLPAPER STRIPPER
Easy to use. Portable. Entirely self contained, so the user can't lose parts.

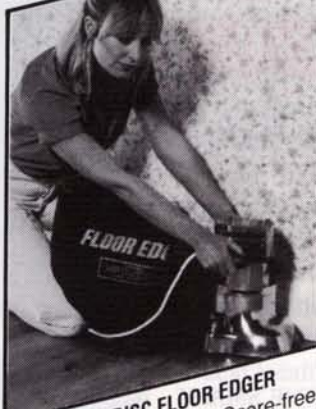

HIRETECH DISC FLOOR EDGER
Lightweight. Versatile. Score-free finishing. Ideal for corners, small floors, stair treads, bench tops.



HIRETECH FLOOR SANDER
For any job - big or small. No bounce. Professional finish - even for the first time user.



AIRLESSCO AIRLESS PAINT SPRAYER Inexpensive to maintain. Sprays most paint coatings. Quick, efficient. Minimal overspray.

NSW 3 Kelso Crescent, Moorebank 2170
Phone (02) 602 3666

VIC 218 Princes Highway, Dandenong 3175
Phone (03) 793 1892

QLD 754 Beaudesert Road, Coopers Plains 4105
Phone (07) 275 1388

Or call us on 008 112 428 from anywhere in Australia for the cost of a local call.

VIKING EQUIPMENT

For information, sales and service, contact:

INSPECT OUR ECONOMY RANGE OF 'DIRTBUSTER WINNER' HIGH PRESSURE WATER CLEANERS

Leading the world - leading Australia

It starts with quality ...

From the time Andreas Stihl produced his first chainsaw in 1926, the insistence on quality of materials, design and workmanship has been an outstanding characteristic of the Stihl approach to business.

As the demand for saws of lighter weight, but greater power grew from the time Stihl produced the world's first one-man chainsaw in 1950, the search for higher quality of materials and workmanship intensified correspondingly and has continued over the succeeding decades.

The relentless quest for quality starts long before a new model gets anywhere near manufacture.

Stihl's heavy investment in research and development is keeping the company at the leading edge of small-engined power tool technology as engineers work on the machines of tomorrow on the basis of today's experience in the field and the anticipation of the needs of the future.

This policy has enabled Stihl to pioneer many developments now common on modern chainsaws - the centrifugal clutch, anti-vibration systems, electronic ignition, and the inertia-activated chain brake among them. Stihl's concern with the science of ergonomics - fitting machines to people with maximum safety and efficiency - has revolutionised the whole approach to powered hand-tool design, producing machines that are perfectly balanced, under control at all times, and keep operator fatigue to a minimum.

This combination of technical innovation and the search for engineering perfection has led to the appearance of the Stihl logo on a much wider range of hand held power equipment than was ever envisaged by the company's

founder.

Brushcutters, clearing saws, blowers and misters, earth auger, masonry saws, wood drills, hedge trimmers, garden cultivators are now among the Stihl product range.

The relentless quest for quality starts long before a new model gets anywhere near manufacture.

Also marketed under the Stihl brand is a range of high quality high pressure water cleaners and vacuum cleaners which have found ready acceptance in the rural, industrial and commercial sectors.

While chainsaws remain the foundation of the worldwide Stihl organisation, the other products have assumed increasing importance as new markets are explored and needs satisfied.

Stihl is Australia's - and the world's leading brand of chainsaw. It owes this achievement to three main principles:

- Strict adherence to product quality standards
- Innovative product design based on the needs of the market
- Heavy emphasis on reliable spare parts and service back-up through a servicing dealer network, hire companies, state and local government instrumentalities

These principles are applied worldwide, but in Australia they have acquired a special importance. A sparse population, vast distances between major centres, widely varying conditions of climate and environment have tested the Stihl philosophy to the full.

It has not been found wanting.

Today, more Stihl chainsaws are being used in Australian forests and farms, parks and plantations, building sites and backyards than any other brand. As well, Stihl brushcutters and clearing saws, masonry saws, augers, drills, blowers, high pressure water cleaners and vacuum cleaners and other powered products, have opened up new markets and brought Stihl quality and reliability to new areas of industry. Stihl Pty Ltd is the Australian subsidiary of the Andreas Stihl Group, which has its headquarters in Waiblingen, West Germany.

The Australian company was established in 1971, although Stihl products had been distributed in this country for many years previously. It began operations in North Melbourne, then shifted to the outer Melbourne suburb of Bayswater in 1973 where, five years later, the company's first production line was set up to assemble the 031 Farm Boss - a name which has become almost a generic term for chainsaw among the Australian rural community.

Another major move came in 1983, when the most up to date chainsaw assembly warehousing plant and offices in Australia were opened at Forbes Close, Knoxfield by the Chief Executive of Andreas Stihl, Mr Hans-Peter Stihl.

Today, the Knoxfield complex is the centre of an Australia-wide operation which covers branch offices in six states and a network of more than 1200 dealers. The network extends overseas, too, with flourishing dealerships throughout the Pacific Islands and New Guinea.

The Knoxfield computerised stock control and inventory service provides overnight spares delivery anywhere in Australia and inventory services for every dealer, while at the assembly plant 9 models of chainsaw are produced from parts imported from Germany and the United States.

SUMNER

NEW 760 Contractor Lift

Sumner offers heavy-duty Contractor Lifts: the rugged 760 with folding legs and forks offers these outstanding features:

- ☆ Lifts 750 pounds
- ☆ Extends to 18 feet
- ☆ 2-speed winch
- ☆ Combination aluminium and steel masts
- ☆ Stabiliser legs

The Sumner Contractor Lifts are by far the best built lifts for the contractor. They offer a combination steel/aluminium mast for minimum mast deflection at 18 feet, a two-speed Sumner-designed winch to handle big 750 pound loads with ease.



Roust-A-Bout

Makes One Man a Crew

- ☆ Lifts 2,000 pounds
- ☆ 15, 20 and 25 foot heights
- ☆ Moves vertically and horizontally
- ☆ Separate load and mast winches
- ☆ 2-speed winch
- ☆ Infinite load adjustment
- ☆ Ideal for job or shop

With the Sumner Roust-A-Bout, one man can hoist and position loads up to 2,000 pounds vertically and laterally simultaneously to heights up to 25 feet in minutes. The Roust-A-Bout eliminates the need of many other tools such as chain falls, come-alongs, scaffolds, monorails and swing booms. In only a few days this unique lift can pay for itself in time saved. The Sumner Roust-A-Bout makes one man a crew!

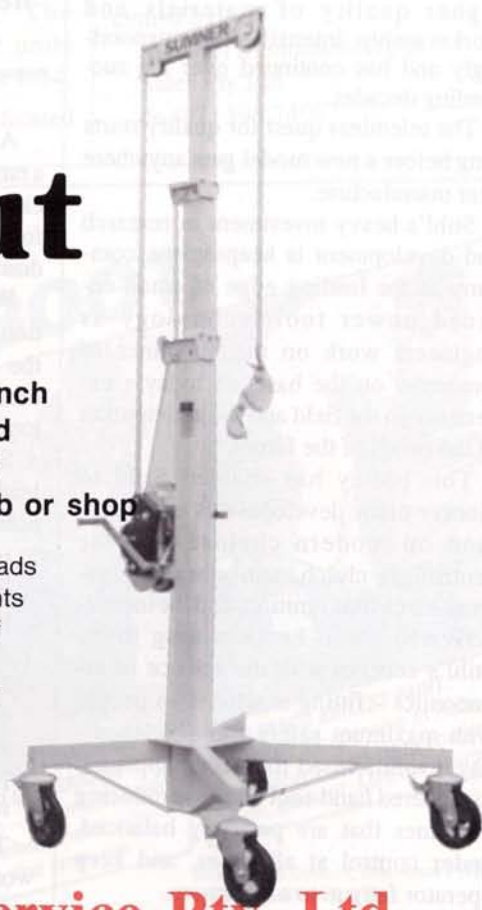

Sales & Service By:

Horizon Access Spares & Service Pty. Ltd.

(Incorporated in N.S.W.)

P.O. Box 437, Ingleburn 2565

Phone (02) 829 1277 (24 Hrs). Fax (02) 618 3632

International honour for industry leader

New South Wales hire association member and well known personality, Chris Pannell, who is a member of the Institute of Plant Engineers, London, was recently advised by the editors of Who's Who in the World that he has been selected for inclusion in the 1990/91 issue of this prestigious work for his "contributions to contemporary society".

We're still trying to find out whether this is because of his eleven children, his honorary membership of the Royal Blind Society and the Scout Association of Australia or his Hirepool group of com-



Chris Pannell.

panies with nine locations on the Central Coast and Hunter Valley of New South Wales dominates this market area (his claim, not ours!).

Anyway, whatever the reasons for this fine achievement Chris, the editors and staff of the Hire & Rental Quarterly offer their sincere congratulations.

We understand that Chris's latest business venture is with the formation of LoveTale Music Pty Ltd with the establishment of recording studios and the production of secular and religious music on tape and compact disc.

Whatever the reasons Chris, congratulations and well done!



DEMBICON

COMPAC

A MAJOR ADVANCE IN
SMALL SAW TECHNOLOGY



Australia's first all-purpose compact pavement saw is a breakthrough in Australian-made small saw design, offering

- High performance
- Easily manoeuvrable
- Rugged, compact frame
- Variable blade depth by fingertip gas cylinder controls
- Variable power options
- Packs into most car boots
- 14" (350mm) blade capacity

COMPAC slices through floors, roads and driveways and is ideal for concrete, sawing & drilling contractors, hire companies and councils. Conventional & laser-welded blades to match.

Have Anita personally autograph your poster at our Expo stand.



DEMBICON AUSTRALIA

AUSTRALIA'S DIAMOND TOOL SPECIALIST

• Adelaide • Melbourne • Sydney • Brisbane • Gold Coast • Perth • Los Angeles • Singapore

Super Service Hotline
☎ 008 888 343

Demountables make a stand



A demountable complex from Prestige Portables, erected in a basement car park.

MAJOR building companies recently have utilised a new system of demountable work buildings, which are ideal for hard-to-reach or covered areas. Prestige Portables hires out the sheds, offices and ancillary buildings, which are made from factory-built panels, measuring 2.4 metres by 1.2 metres.

"The panels, which have a patented, trouble-free joining system, are carried in individually and easily erected," said Jim Oman, sales manager of Prestige Portables.

"They are useful for places which are difficult to get at, or in covered areas such as basements and carparks, where use can be made of existing floors and low ceilings.

"Buildings can be erected with or without roofs or floors, directly onto a concrete floor or under a low, carpark ceiling.

"Panels also can fit into a goods lift or may be craned to upper floors.

"The end result is a building which is well-presented, fully lined inside and out, fitted with power and light modules, and which can be air-conditioned, furnished and equipped as required."

Mr Oman said a major advantage to contractors of inside worksheds was a reduction in lost working time during wet weather.

Prestige Portables provided a demountable system for Thiess Contractors on a construction project at Rosebery in Sydney.

Initially, the site allowed enough room for fixed sheds but, as the project developed, they had to be removed to allow further excavation.

By the time they were removed, the basement of the new building had been com-

pleted, and Prestige Portables arranged for a demountable complex to be carried in and erected. The complex included 11 buildings - change rooms, lunch rooms, first aid room and site office.

The solution allowed work to proceed without interruption, and the new location of the sheds was also advantageous during wet weather.

C.H. Webb Bros hired a demountable complex during construction of a multi-storey carpark at Parramatta.

The complex, which was erected in the lower section of the car park, included an ablutions unit and a 72-man lunch room, which was made by enclosing a large section with wall panels.

There was no need for a new roof or floor because of the existing concrete base and low carpark ceiling.

Leighton Contractors hired 11 demountable buildings from Prestige Portables during construction of the luxurious Cecil Apartments overlooking Cronulla Beach in Sydney's south.

Ten lunch and change rooms for workmen and sub-contractors, as well as a first-aid room, were split into two complexes on different basement levels.

Mr Oman said Prestige Portables had a large fleet of demountable buildings available for hire.

"They have proved so popular, 90 per cent are out most of the time," he said.

"Another of the many advantages of these buildings is that you can move them around within a site and even re-design the layout," Mr Oman said.

"Because it's a modular system, you can have buildings any size you require.

"We truck the panels to the site, where they are unloaded either manually or by forklift.

"Hirers can choose to assemble the buildings, or allow us to do it for them."

High tech builders hoists



Sydney Hoist Rentals was recently contracted to supply two 30 metre high double barrow hoists.

With a very limited area of less than 2.2 square metres Sydney Hoist Rentals selected the new TT3 500kg hoist from Transmission Technology.

A light weight unit with fully detachable axle assembly was easily positioned by 2 riggers and was fully erected in one day. A new safety feature installed for this installation was the electric overload device set at 500kg to prevent overloading. Also electrically interlocked gates were provided for increased operator safety.

For further information on the complete range of high tech builders hoists contact;

Transmission Technology
50 Prince William Drive
Seven Hills NSW 2147
Ph (02) 674 1611
Fax (02) 674 5123

STICKER ORDER FORM

- | | | |
|-----------------------------|--------------------------------|---|
| A1 Park & Run Level | B1 Rotation | C1 Empty Bag Before Returning |
| A2 Use Distillate Fuel Only | B2 Tyre Pres. Front Rear KPA | C2 Clean Before Returning |
| A3* Use Fuel Supplied Only | B3 Use in Well Ventilated | C3 Extra Charge if Returned Dirty |
| A4 Check Oil Daily | B4* To Lift Maximum of kg | C4* Cylinder Fitted With Left-Hand Thread |
| A5 Use Two Stroke Only | B5 Rotation | C5* Flammable Gas (Red Lettering) |
| A6 Standard Petrol Only | B6* Drain Daily | C6 Unleaded Petrol |
| A7* Special Oil Only | B7 Prime Pump Before Use | |
| A8 Use Kerosene Only | B8 Keep Clear of Blade(s) | |

Maximum 80 Speed (Sold Separately at 20¢ Each)

'Important' (Sold Separately at 20¢ Each)

* These stickers are 'SPECIALS' at a cost of \$1.00 whilst stocks last

To: Hire Association of N.S.W.
 P.O. Box 613
 Baulkham Hills, 2153
 Tel: (02) 634 2964

Please supply (Name of Company)
 of (Address)

Type	Quantity (No. of Packs)	Type	Quantity (No. of Packs)
_____	_____	_____	_____
_____	_____	_____	_____
_____	_____	_____	_____
_____	_____	_____	_____
_____	_____	_____	_____

Total number of packs ordered at \$4.00 per pack (Member) or \$5.00 per pack (Non-Member) plus postage, making a total of \$ Cheque for \$ attached.

'SPECIALS' available at \$1.00 per pack.

New Sticker available:

'IMPORTANT. This equipment may lawfully only be used by the holder of a Certificate of competency issued under the Construction Safety Act'

Cleaning concrete effortlessly!

Concrete is everywhere. It is the universal building product for office blocks, factories, paths, driveways, parking stations and floors.

But daily exposure to dirt, soot, motor oil, food spills, and the like, can turn the construction advantages of concrete into an ugly mass of visual pollution lowering the image of retail and commercial centres, business premises and households.

With the environment becoming such a headline-grabbing subject, it should come as no surprise that people are noticing the unsightly appearance of dirty concrete. And this presents a challenge to would-be concrete cleaners.

Generally, most concrete can look 'as new' simply by removing the top surface inground dirt and grime - taking up slime, food, gum, and other things similar. All you can really clean of anything is its surface.

By far, these substances represent the most common need for concrete cleaning jobs, none of which can be effectively done with a garden hose or physically tiring scrubbing effort.

If you really want to clean concrete and save wasted manual cleaning effort, then the only thorough way is to use a high pressure water cleaner.

High pressure water cleaning will remove practically all surface dirt with ease. Soils such as grease or oil spills, pre-treatment with a suitable ecology-safe detergent is recommended for best results. But again, the key word here is "surface". Concrete is porous and if not sealed, some spills absorbed below the surface may be difficult to remove completely.

Areas with deep-seated oil problems such as driveways, and parking lots, detergent pre-treatment and wet sandblasting may offer the best shot at removing the stains. A wet grit blaster

Graffiti removal using Gerni 600p with wet gritblasting attachment.



comes as an optional accessory with some brands of pressure cleaners.

Cleaning concrete that's vertical, such as the sides of buildings, is easier to clean because it's soil has not been trafficked in. The dirt is more 'dust-like' and is generally removed effortlessly with a high pressure water cleaner.

Hot water equipped pressure cleaners can make cleaning concrete a much simpler operation, especially when there's sticky substances to remove. Syrup, for example, is easily stripped from the surface. Hot water also increases the cleaning efficiency and in some cases, eliminates the need of detergents.

While environmental awareness has brought about sweeping changes to the way people approach concrete cleaning and maintenance, the same cannot be said about numerous brands of pressure cleaners.

You should bear in mind before making your purchase decision that almost every pressure cleaner brand, except genuine Gerni, are equipped with a conventional fan-jet type nozzle which lose up to 85% of their cleaning power at a distance of only twenty centimetres.

This lack of nozzle technology means the more pressure you need, the bigger the pump has to be. But you still lose 85% of your cleaning power at 20cm while you spend more on power, energy and water volume.

If you go by popularity of pressure cleaners across a broad range of industries and households, then you'll find the name Gerni high pressure water cleaners emerge as the number one choice. And there are very sound reasons why.

Gerni has been around for more than 25 years and its continual improvements in water pressure technology

Continued on page 91

Cleaning concrete effortlessly

From page 90

and environmental concerns has advanced the range light years ahead of the rest.

Gerni technology has done away with inefficient conventional fan-jet nozzles, replacing them exclusively with Turbo Laser cleaning power and performance.

Turbo Laser equipped Gerni delivers up to 7 times the striking force and cleaning performance of Conventional fan-jet equipped pressure cleaners. Cleaning is done in half the time and with less effort.

Another feature is Gerni's three-piston pump. It is compact and powerful. And uses less kilowatts of energy over the high cost and wasted power of many other pressure cleaners pump and motor. The result is better output efficiency and reduced running expenses in a compact, more manoeuvrable machine.

With Gerni Turbo Laser, the water drops forced from the nozzle are 10 times larger than those from a normal nozzle



Turbo laser powered Gerni restores dirty, grimy concrete 'as new'.

and 1000 times heavier. Propulsion is 400-600 kilometres per hour. Dirt, grime and the like don't stand a chance of remaining on the surface to be cleaned.

Gerni Turbo Laser technology cuts harmful aerosol effect. And in hot water equipped Gerni, those big laser drops don't cool down as rapidly as those in a conventional fan-jet type spray. The hotter the water, the quicker it cleans so you save more on detergent use, time, labour,

power and water.

When you compare all the features and benefits of Gerni, its not hard to explain why Gerni enjoys such popularity. Service and spare parts are not a problem. Gerni is distributed and backed Australia-wide by Australian owned Viking Equipment (Aust) Pty Limited who are happy to show you the right Gerni, recommended detergent and accessories to suit your needs obligation-free.

Dembicon's new COMPAC small saw - a 'breakthrough'

Leading diamond tool specialist Dembicon Australia has released Australia's first all-purpose compact pavement saw.

Called the COMPAC, it is a high performance Australian made unit offering revolutionary technology and design in a ruggedly built yet compact frame.

The COMPAC is light to carry and easy to use. Its versatility makes it ideal for sawing floors, roads, footpaths, driveways, parking lots and patios, as well as for decorative sawing or outlining asphalt and concrete patches.

Dembicon says the COMPAC is particularly suitable for concrete cutters, hire companies, councils, sawing and drilling contractors.

The COMPAC features a strong 1/4" (7mm) structural steel frame and baseplate rolled edges for stronger life.

Fingertip controls on the folding handlebar include Dembicon's exclusive raise/lower mechanism to infinitely vary blade depth. Its 14"

(360mm) blade capacity can cut to a depth of 4-5/8" (116mm).

Sturdy 10" (254mm) rear wheels mean the COMPAC can be easily walked over curbs and other obstacles.

The COMPAC's power source is the dependable Briggs & Stratton Vanguard 8 HP petrol engine although optional models available are the 7.5 HP Robin, 8 HP Robin and 8 HP Kohler.

A full range of conventional and laser-welded diamond blades to suit the COMPAC pavement saw is available from Dembicon outlets in all mainland capitals or by telephoning the Super Service Hotline on 008 888 343.

Dembicon is Australia's largest diamond tools specialist, supplying diamond tool and blade requirements through offices in Adelaide, Melbourne,



Dembicon Australia's COMPAC all-purpose compact pavement saw.

Sydney, Brisbane and Perth.

The company is also a major supplier to the South East Asian region through offices in Singapore and Hong-Kong as well as on the United States' west coast.

Further information: please contact Lloyd Williams, Managing Director (08) 297 4022.

Touch of class for portable office



The portable office complex supplied by Prestige Portables for Union Steel.

An interior decorator added a touch of class to a portable office complex hired by steel merchants, Union Steel Co, during a major construction project.

Prestige Portables supplied and installed the factory-built complex to serve as a project office for Union Steel during planning and building of a new, \$20 million plant at Ingleburn, in Sydney's south-west.

The complex included a project manager's office, long meeting room and a large, open office for a receptionist and three or four other staff.

Although naturally well presented, with timber panelled walls and carpet, the complex received its extra classy look from interior decorator, Margaret Roil.

Ms Roil, of Corporate Decor at Castle Hill, said some staff were apprehensive about moving into the portable offices.

I decided that we would provide a setting to make other staff sit up and say, 'Wow!', Ms Roil said.

By the time we had finished, people would walk in with a preconceived idea and get a lovely surprise."

The effect was achieved through the use of colour, furnishing and "a bit of thought."

Ms Roil chose grey desks, which blended in with the colour of the carpet, and put some brilliant colours into the chairs and slimline venetian blinds.

Wall hangings and pot plants finished off the low-budget project.

Ms Roil has since helped Prestige Portables develop a display office which shows just how attractive portable offices can be.

Bruce Farquhar, a director of Union Steel's project planning team, said the portable complex, which was erected alongside the company's old premises at Chester Hill, was very successful.

"There was no point putting up a new building, as the likelihood is that whoever buys this site will raze it," he said.

"While they were portable units, they were good quality, and were done up as nicely as any office you would see."

Prestige Portables, with branches in Sydney, Newcastle and Brisbane, hires out offices and other portable buildings for use in a wide range of situations.

"These buildings, which can be delivered where required, provide a simple, effective and, above all, flexible option," said Gordon Esden, managing director of Prestige Portables.

"They may be useful during early stages of an operation or later expansion, when long-term needs are uncertain.

"Also, they can fill a gap while regular work areas are being remodelled, renovated or relocated."

Mr Esden said it was possible to hire a single unit, or an entire, modular complex.

"Ready-built, portable units can be delivered on site within 48 hours," he said.

"Alternatively, we can provide made-to-order modular buildings in 10 days from agreement on design.

"The modular system allows you to start with the bare essentials and add extra units as the operation grows.

"As needs change, you can also relocate or dismantle.

"Instead of the shape or size of an office dictating what you can or can't do, this modular system puts management in control."

Mr Esden said offices provided by Prestige Portables offered a working environment as good as many conventional offices.

"They are bright, modern, insulated and can be carpeted, air-conditioned and fully furnished.

"Clients have a choice of claddings, fixtures and accessories such as awnings and verandahs, while toilet facilities, kitchens and even shower rooms can be included."

Prestige Portables Pty Ltd,
15 Rowood Road,
Prospect, 2149.
Ph: (02) 688 2688, or
Toll Free (008) 267979.

Makita

Demolition Hammers

Makita's expertise and dedication to the development of superior demolition hammers has resulted in a new generation of construction hammers that provide the performance, reliability and durability that you've come to expect from the world famous range of Makita power tools. Get the job done quickly, quietly and with less fatigue. All models feature automatic brush cut out, for motor protection. Three models that will indeed live up to their names ... The Demolishers.

- ELECTRIC BREAKER

Model HM1400

No other breaker in its class has the weight and speed for this kind of powerful impact!

- T-type design with top lever switch for easy and safe operation • Air cushioned system prevents excessive vibration and allows greater operator comfort • Grease pack system good for



150 straight hours of demolition • Ideal for spade work, ramming and tamping of backlifting work.

- DEMOLITION HAMMER

Model HM1300

Best in its class for speed, impact and

low weight.

- side handle swing full 360° • improved operation and durability • Well-sealed to prevent dust entry • Complete range of accessories available • Excellent for percussion, cutting away, digging, tamping, scaling • Grease pack system good for 150 straight hours of demolition.

- DEMOLITION HAMMER

Model HM1200K

The lightest, easiest handling and smallest demolition hammer in its class.

- Antivibrating spring positioned between handle and motor housing for fatigue free operator safety and comfort • Rugged, powerful-grip tool retainer • Big rubber grip swings full 360° • Grease pack system good for 150 straight hours of demolition • Cooling air flows forward (away from the operator) • Accepts Hex Shank and Kango type hits.

Strongarm lifts anything



The "Strongarm" at work.

The Strongarm can be affixed to any tray truck, trailer or van. It is easily fitted by way of a base plate that screws into the floor of the vehicle. This "portable" unit is erected for use by unfolding a strong support "arm" and a "leg" which

bears all the weight and stands outside the vehicle. After use, it folds neatly away leaving plenty of space.

Strongarm can lift anything from a large ram, if you need help on the farm, to a stack of gardening sleepers for the

keen home or professional gardener.

Strongarm is currently in use by Councils and Shires where jobs that were once "backbreakers" are now being performed by Council workers with ease.

Strongarm can be that "extra hand" for farmers, removalists, builders, professional tradesmen, the home handyman or even boating and outdoor enthusiasts.

Specifications:

2 sizes with a safety approved lifting capacity of 200kg* and 500kg*.

It rotates at an angle of 360°, includes hand winch and 2 position jib, mounts easily with requisite parts supplied and the use of minimum tools.

*DLI Approval pending.



Adelaide Convention Centre

Venue for this years 19th
International Hire Convention

EXHIBITORS' SHOWCASE

19TH INTERNATIONAL HIRE CONVENTION & EXHIBITION

**Adelaide Convention Centre
10th - 14th September 1990**

ADELAIDE

90

AJC Sales & Service

4 Bowyer Road, Wingfield, SA, 5013
Tel: (08) 347 1498 - Fax: (08) 243 0841

AJC was incorporated in South Australia 2 years ago and is the proud distributor of:

- Bitelli rollers, asphalt pavers and cold planers
- Bernardi asphalt plants
- FMC street pavers
- Sky trak rough terrains forklifts
- Scat Track skid loader

All of the above equipment is well known and respected in the industry. Some of the smaller machines will be on display, with videos, literature with help and advise from our friendly staff.

Aggreko Generator Rental

305-307 Boundary Road, Braeside 3195
Tel: (03) 587 5011 - Fax: (03) 587 5054

Aggreko Generator Rentals established a presence in Australia in September, 1989 under the direction of Bill Black, previously Operations Director of Aggreko Generators in the U.K.

Head Office is based in Melbourne with branches situated in Sydney, Newcastle, Perth and agents in Adelaide, Brisbane, Darwin and Tasmania.

Aggreko Generators Rentals local agent is Richard Stevens Hire, 617 Goodwood Road, Panorama 5041, (08) 277 0022, a well known and long respected hire company with branches across Adelaide.

Aggreko Generators range in power from 15 to 1825kva in single units. Larger loads can be catered for by paralleling multiples of sets. Also available are cable, transformers, load banks, (resistive and reactive) and fuel tanks.

Alscaf

2/82 Cosgrove Road, Strathfield South,
NSW 2136
Tel: (02) 642 6533 - Fax: (02) 642 8442
Toll Free: (008) 252 802.

Alscaf Pty. Limited is a Sydney based company specialising in the manufacture, sales and hire of aluminium mobile scaffold towers and swinging stages.

On display at the Adelaide Hire Expo will be a range of products including our modular stage decking and aluminium mobile scaffolding. The modular stage

decking represents an innovative concept in staging being durable, compact and competitively priced.

Our aluminium scaffold too, is most durable being constructed from 2.6mm wall thickness tube. This elementary advantage coupled with many other extraordinary features makes Alscaf aluminium scaffold the ideal option for the rental market.

The stand in Adelaide will be manned by Bill Kelly, Maurie Abbott and John Lyons who between them represent a wealth of experience in the scaffolding industries.

Austquip Pty. Ltd.

19 Manton Road, South Oakleigh, VIC
3167
Tel: 544 4066

Austquip Pty Ltd formerly A&N Equipment a division of A&N Plant hire has been actively involved in the rental industry for the last 20 years and has a first class knowledge of the hassles of the hire industry. All products produced by Austquip are built to stand up to the abuse given to our equipment and are modified where required should it be necessary to do so.

They are well known throughout the industry for the Mang Rotary Tillers both rear and front type, up until the end of last season they were producing these machines in Australia but have now reverted back to importing from U.S.A. the rear type jr2000 which is now being produced by Merry Tiller with our modification incorporated.

They will also be exhibiting our line of chippers, mulchers and also their mini trencher.

They are looking forward to seeing you at the Adelaide Convention & Exhibition.

Bianco Builders Hardware

178 Gorge Road, Newton, SA 5074
Tel: (08) 336 666 - Fax: (08) 336 6429

Bianco Builders Hardware, incorporating Bianco Hiring Service have been active in the building industry for over 10 years. Scope of activities include builders hardware, safety, steel, hire service of various equipment including workshop repairs and machinery sales. The product on display is the Bianco Diamond B Masonry Saw.

Bianco Diamond B Saw comes with either a 5HP petrol or a 1 1/2HP drip proof, single phase, flame-proof electric motor. Both machines are completely portable and the mechanism can be used either on the supplied stand or on your own work bench.

The saw comes in two sizes - one for the 350mm, and one for the 500mm blade. It can be used for wet or dry cutting and accessories include a flexible water pump for use when there is no easy access to water, or when conditions prohibit the use of running water. It can be operated by engaging either the hand lever or the foot pedal. It's ideal for single cuts, but high volume cutting is made much easier by attaching the angle jig - thereby enabling you to make as many identical cuts as you like from just one adjustment.

The Bianco Saw cuts your work in half and is a must for all those who work with masonry.

The saw can be manufactured in fleet colour to suit hiring companies. All enquiries are welcome.

Blackwood Hodge (Australia) Pty Ltd

Port Wakefield Road, Cavan, SA 5094
Tel: (08) 260 1066

Blackwood Hodge have participated in the Hire Convention and Exhibition each year since the acquisition of the Dynapac range of compaction equipment. Blackwood Hodge will be releasing the following new products from Dynapac at the convention.

LA90 articulated 1.2 tonne roller fitted with drive and vibration on both drums.

LG200 236kg forward and reverse plate compactor powered by Faryman diesel engine.

LG550 525kg forward and reverse remote control plate compactor powered by Hatz diesel engine fitted with electric start.

AL High frequency concrete pokers and frequency convertors.

Blackwood Hodge will also have on exhibition a range of forward plates and compactors, tampers and pokers. Information will be available on the complete range of Dynapac rollers and Hitachi excavators.

They welcome you to the exhibition. Both the Blackwood Hodge and Dynapac representatives look forward to seeing you at their stand.

Continued on page 97

From page 96

BlueBird Floor Cranes Pty Ltd

33 Little Hoddle Street,
Richmond North, VIC, 3121

Tel: (03) 417 1515 - Fax: (03) 419 8884

Although only two years old, BlueBird Floor Cranes is backed by a wealth of "hands-on" experience in the hire industry - for nearly 18 years principals Jim Nilsson and Graham Hoinville ran their own general plant and tool rental operation in the Melbourne suburb of Abbotsford.

They have represented BlueBird International Inc. of Denver, Colorado, USA since they introduced BlueBird products into Australia in 1975. The popular BlueBird KD1500 Floor Crane is now manufactured in Australia under license.

The steel components are fabricated from quality BHP steel to the same high standards of engineering and finish as American-built units, while the tried and proven long-ram jack (built by the makers of the renowned Blackhack and Porto-Power equipment) is sourced from USA. The unique safety features of the BlueBird ram - overload and over-pumping protection and controlled let-down of load - are of increasing importance under occupational health and safety legislation now impacting the hire and rental industry.

Briggs & Stratton Australia Pty. Limited

3 Conifer Crescent, Dingley, VIC, 3172
Tel: (03) 551 7066 - Fax: (03) 551 7981

Unit 9, Slough Business Park
Rachael Close, Silverwater, NSW 2141
Tel: (02) 648 3466 - Fax: (02) 647 2304

2/49 Annie Street,
Coopers Plains, QLD, 4108
Tel: (07) 875 1175 - Fax: (07) 875 1769

Millamac Pty Limited
5 Arwon Court, Lonsdale, SA, 5160
Tel: (08) 326 0855 - Fax: (08) 383 3359

Bell Strike Pty Limited
85 Beechboro Road, Bayswater, WA, 6053
Tel: (09) 370 4333 - Fax: (09) 370 4340

Briggs & Stratton is the world's largest manufacturers of air-cooled petrol engines, with a range from 3 to 18 HP, vertical and horizontal shaft.

Briggs & Stratton Australia is responsible for the company's business activities in Australia and distributes

product to over 1,000 dealers Australia wide.

During 1990 Briggs will launch the full range of Vanguard-OHV engines.

The Vanguard-OHV range, billed as Briggs "Top Guns", this new range of engines features overhead valve technology at its best.

The Vanguard-OHV range of engines will be available in the following horsepower ranges:

- 9HP, 12.5HP, 16HP horizontal shaft and
- 5HP, 12.5HP, 14HP, 16HP vertical shaft.

The Vanguard-OHV V-twin configuration engines equipped with full pressure lubrication will surely set new industry standards in their horsepower ranges.

Compact Disc Jukebox Party Hire

399 Parramatta Road, Leichhardt,
NSW 2040

Tel: (02) 546 1022 - Fax: (02) 550 9294

They will have on display three models at this year's Hirexpo. This includes their newest release 1950's style compact disc jukebox, which promises to be a real eye catcher ideal for the 50's, 60's theme parties.

Also on display will be our Mini Portable Compact Disc Jukebox. Fully portable, this CD Jukebox has the same capacity as its big brother, but at a fraction of the size and weight. Hire customers can now pick up and return jukeboxes themselves, saving you time and labour and increasing your profits.

Once again on display will be the standard CD jukebox, which has already proven to be a success with the party hire and general hire industry over the years.

Cranford Products

39 Pakhurst Drive, Knoxfield, VIC, 3180
Tel: (03) 800 1711 - Fax: (03) 801 4348

Cranford Products are the Australian importers of Oleo-Mac power products and have a solid distributor network capable of maintaining a high level of service and spare parts back-up in all states. Cranford Products are also Australia's largest supplier of chainsaw spare parts and accessories along with workshop tools all of which are available from distributors in each state. Oleo-Mac

offer a wide range including:

- Chainsaws from 34cc to 100cc. Included in the range is the Blitz and Handy saw.
 - Cut-Quicks. Oleo-Mac offer both 12" and 14" units.
 - Earth augers; 2 man and 1 man
 - Electric chainsaws. A powerful 2000W unit and the E140F a 1400W saw.
 - Hedge trimmer attachments for chainsaw model 935 and Handy saw.
 - Brushcutters. Oleo-Mac have brushcutters from a bent shaft 18cc unit through to a powerful 40cc back-pack
- Cranford will be displaying a full range of Oleo-Mac products and look forward to meeting delegates.

Crommelins

139 Welshpool Road, Welshpool,
WA 6106

Tel: (09) 451 6644

Robin Engines:

The successful association of Robin Engines and the Australian hire industry is 23 years old and going strong. You won't find a tougher test for a range of small stationary engines and a national back-up required to keep them running.

Crommelins Australia, who have been the sole national importer of Robin engines for the past 23 years, are now the third largest importer of small stationary four stroke petrol and diesel engines in Australia, and they offer more than 70 different Robin models in either horizontal or vertical shaft.

Spare parts and service support is available through key distributors in each capital city and a vast network of country and metropolitan dealers. Meet Greg Solin, Mark Flanagan, Frank Calleja and the full range of petrol and diesel engines at the Adelaide Hire and rental Exhibition.

Dembicon Australia

29 Kinkaid Avenue,
North Plympton, SA 5037
Tel: (08) 297 4022 - Fax: (08) 371 0990

Dembicon Australia's new all-purpose compact pavement saw - the COM-PAC - and a new ceramic tile cutter regarded as the most advanced in the world will be among products on show for visitors to the Dembicon display stand at the 1990 HireExpo in Adelaide.

Continued on page 98

From page 97

COMPAC's pace-setting technology and design have already attracted widespread acclaim from contractors and hire firms. Visitors to Dembicon's display stand at Expo will be able to assess for themselves the advantages of the Australian-made unit's rugged construction, easy manoeuvrability and efficient operation.

The Rubi D-200 Electric Tile Saw will also be on show. This highly regarded and versatile portable wet tile saw is distributed exclusively by Dembicon in Australia and was one of the most popular products at the Cologne Building Products Exhibition. Its mitring capability is suitable for all ceramic tiles, marble, granite and terracotta.

Weighing a mere 18 kilograms, this 2800rpm 240V saw has an adjustable cutting height and unlimited cutting length.

Expo visitors can also see Dembicon's money saving PRO HS range of blades for all hand sawing applications - developed after an exhaustive research and development program - as well as the powerful and time saving Partner range of power cutting tools.

Dembicon's expert technical staff will be on hand throughout the Expo to answer delegates' questions.

Dembicon is Australia's leading diamond tool specialist, manufacturing an extensive range of cutting and drilling machinery, blades and bits.

Their innovative manufacturing integrates the latest overseas technology and their products are backed by an enviable 24-hour service on parts.

Dembicon Australia - successfully servicing the cutting and drilling requirements of construction and hire industries throughout Australia, South East Asia and the west coast of the United States.

Easylevel

P.O. Box 556, Mt Barker, SA. 5251
Tel: (08) 388 9553 - Fax: (08) 388 9552

For the professional builder, landscaper, greenkeeper or keen home gardener, the Easylevel is the ideal tool.

The Easylevel does away with the back-breaking bending associated with traditional levelling methods.

Like so many brilliant tools it is remarkably simple - levelling sand, dolomite, screenings and loam quickly and easily.

Its ingenious self-levelling mechanism ensures a perfect level every

time.

Starting with an Easylevel mainframe, any or all of its interchangeable attachments provides the precise tool for any need - levelling a paving base in a tight corner or top-dressing a tennis court.

The screed bars range in size from 1 to 2 metres with a rake attachment specially designed for lawn planting.

The Easylevel's sturdy construction guarantees years of precise maintenance-free operation and users will wonder how they managed without one before.

Fein Power Tools (Australia) Pty Ltd

134 Bonds Road, Riverwood, NSW, 2210
tel: (02) 534 3533 - Fax: (02) 533 2650

In 1985 Wilhelm Emil Fein invented the world's first power drill, this ancestor of Fein's modern high performance power tools is considered the first power tool in the history of technology.

The progress that this tool made in the areas of trade and industrial applications led to the development of the Fein high performance power tools that is well known to the professional industries of today.

At this year's Hire Exhibition Fein will have a total hands on exhibition for visitors, our staff Mr John Buckler - State Manager, Victoria - and Mr Darryl Kenny - Marketing Manager - will be on hand to answer all questions on the range of Fein available to the hire industry.

Festo Pty Ltd

Adelaide - Fax (08) 234 1429
Brisbane - Fax (07) 391 5546
Melbourne - Fax (03) 795 9787
Perth - Fax (09) 470 2140
Sydney - Fax (02) 748 3161

West German Power tools manufacturer, Festo, are exhibiting a range of products which are ideally suited for use in the Hire Industry in Australia.

Acknowledged in Europe as the most innovative of the European power tool-manufacturers, all Festo's products are built for industrial applications, whilst complying with worldwide safety standards.

The RW900E hand held stirrer is ideally suited for all mixing operations on building sites (concrete, mortar, plaster, paint, glue, etc...), and an exten-

sive range of paddles is available.

With over 50 years experience in the manufacture of portable electric circular saws, the Festo range (10 saws in total) caters for all demands; blade sizes from 160mm to 350mm diam.

Many of the circular saws feature MMC electronics (benefits include motor overload protection) and all come equipped as standard with quality carbide blades.

The range of sanding equipment includes orbital sanders, disc sanders and eccentric disc sanders, all with dust extraction capability.

Dust extractors or industrial vacuum cleaners are available for all wet or dry applications, including one model approved by the DLI for asbestos removal.

The portable, hand held, electric planer model HL850E, with revolutionary one blade, depth of cut adjustment and low noise level during operation sets new standards for this type of tool.

Also on display is the model PS1E jigsaw, already highly regarded in the industry.

For further information on any of these products, visit our stand at the Hire Expo, or contact your local Festo Office, located in all mainland capitals.

Flexible Pipe Cleaning Tools Pty Ltd

8-10 Palmer Crt, Mt Waverley, VIC. 3149
Tel: (03) 543 8722 - Fax: (03) 544 5492
QLD (07) 394 3801
SA (08) 234 2007

Flexible Pipe Cleaning Tools specialise exclusively in all types of Sewer & Drain Cleaning Equipment. Apart from providing new equipment supplies with an excellent after sales service, we also have been expert repair facilities available to facilitate quick equipment turn around, which is essential for the Hire, Rental & Plumbing Industry.

We are distributors of Electric Eel, Rothenberger, Ridgid, Marco equipment and we repair and service *all* brands.

Electrical and manual drain cleaning equipment is available, plus spares are kept for all popular items.

- **ELECTRIC EEL**

A very popular drain cleaning machine, versatile and easy to operate by the hire customer. Its simple design makes it very reliable, and thus a low maintenance (and low operating cost) plant item.

Continued on page 99

From page 98

- **ELECTRIC EEL "TRS" CABLES.**
Flexible introduced this superb cable to the hire industry a few years ago and it has become the industry standard. The hire, rental and plumbing industries appreciate the additional wear and tear this cable offers and the corresponding reduction in operating cost.
- **ROTHENBERGER**
Another very popular machine with many fine features, Its compact design allows it to be used inside buildings and in small, confined areas... a must for many plumbers and house holders. The machines ability to use smaller cables (right down to 9mm dia) gives it a much wanted flexibility and it can be used in sinks, small waste lines as well as 100mm & 150mm sewers and drains.
- **HAND OPERATED DRAIN SETS**
Owing to their ease of operation, these flexible hand sets are very popular with hire customers, for mainly small jobs. They come in Solid Rods and Coiled sections, are simply screwed together and are ready for the job.

Jimmy Farrugia will be at the Exhibition to advise you on the best package for your particular need and help you with any problem that you might have. We try hard to give excellent service to our customers and it's pleasing to see so many of you taking advantage of it.

Flextool Aust. Pty Ltd

191 Wellington Street,
Collingwood, VIC, 3066
Tel: (03) 419 6300
NSW - (02) 818 5722
QLD - (07) 252 2306
SA - (08) 296 1511
WA (09) 451 2077

A big welcome to all delegates to the 1990 Hire Convention from the friendly team at Flextool.

We invite you to call at our stand and inspect our comprehensive range of "Hire Proof" equipment.

On display will be our flexible shaft driven concrete vibrators and submersible pumps together with a wide selection of equipment which we know will whet your buying appetite.

Of particular interest will be the new model 1400 KANGO electric demolition hammer.

This hammer is powered by a tough 1400 watt motor and has been desinged with a minimum of moving parts to ensure ultimate reliability. The quick change latch mechanism at the business end of the hammer accepts all current model 900-950 and 1100 series tools and accessories. This new hammer is a must when updating your hire fleet.

STOP PRESS: We have just released our new Product Catalogue. Be sure you pick one up.

**Helpful
Inovative
Resourceful
Experienced**

That's the Flextool Team.

Hitachi Sales Australia Pty Ltd

153 Keys Road, Moorabbin, VIC, 3189
Tel: (03) 555 8722
NSW: (02) 666 3088
QLD: (07) 260 1344
SA: (08) 347 1234
WA: (09) 277 9855
TAS: (002) 72 5651

Hitachi's new electro-pneumatic hammer drill/ driver is a must for all hirers! This "all in one", well designed tool is capable of drilling solid 22M/M in concrete! With a variable speed and reversing 700 Watt motor, screwdriving and slow start applications are a breeze. Side handle, depth stopper, chuck adaptor, and carry case are standard accessories for this model.

A 12Volt cordless impact drill and non ferrous cutting slide compound saw will be displayed alongside Hitachi's extensive range of drills, grinders, demolition hammers, sanders, saws, cut-off machines, and various other metal and woodworking tools.

Ingersoll-Rand Australia Ltd

Tel: (03) 794 1611 - Fax: (03) 791 8516
NSW: (02) 648 5055
QLD: (07) 277 3511
SA: (08) 352 6122
WA: (09) 277 2211

Ingersoll-Rand have an extensive range of equipment that will provide reliable performance in the rental application.

The extensive range includes:

- heavy duty paving breakers
- portable air compressors

- single and double drum vibratory compactors
- multi tyred rollers
- pavement milling machines
- Ingersoll-Rand Allatt pavers

A wide range of products from one supplier.

Instant Scaffolds

Artamon: (02) 439 6200
Bankstown: (02) 708 6422
Girraween (02) 636 6600
Newcastle: (049) 69 4133
Woolongong: (042) 263 429
Clayton: (03) 543 5566
Hobart: (002) 343 747
Adelaide: (08) 234 1200
Perth: (09) 481 2060
Brisbane (07) 391 2222
Gold Coast (075) 346 066
Cairns: (070) 331 400

Instant Scaffolds, an all Australian owned company with branches nationally, will be displaying a range of equipment at the 19th International Hire convention and Equipment exhibition in Adelaide 10-14 September, 1990.

Instant Scaffolds products include mechanical access equipment, including the highly successful range of Instant Zip-up aerial work platforms, plus a comprehensive range of light weight scaffolding. Contacts on the Instant Scaffolds stand to obtain more information are Mr Eric Kreig, of the South Australia branch and Mr Phil Zeitsch or Mr Peter Ellington of the Sydney branch.

Jaden Pty Ltd Mini Loaders

P.O. Box 54, Burleigh Heads, QLD 4220
Tel: (075) 93 4567 - Fax: (075) 93 4398

Jaden have been involved in the mini loader industry since 1982, having first desinged and built the Dingo mini loader. This old design has now been replaced with a much improved model designed for use in the hire and rental industry during the 1990's.

The *Jaden Mini Loader* (winner of the Australian Design Award) is a versatile hire tool with a large range of attachments, eg. buckets, post hole borer, augers, carryall/leveller, ripper, trencher, rotary broom, concrete mixer and backhoe.

The above products will be on display and to help and advise you at the exhibition will be: Mr Alister Rayner -

Continued on page 100

From page 99

Manager of Jaden Mini Loaders; Mr Trevor Godferdson - Managing Director of Ausdig Sales and Service - Jaden Mini Loader agents in Melbourne and Sydney.

Kärcher

Kärcher Pty Ltd is a subsidiary of Alfred Kärcher GmbH, West Germany who have been manufacturing cleaning equipment for fifty years with world wide distributors. Our range is extensive and of the highest standard with a complete after sales service which cannot be surpassed.

Due to massive growth, in June 1989, Kärcher moved their Melbourne based Head Office and Sales branch to new, larger premises in Noble Park and are now well geared for the marketing challenges of the 1990's.

With the completion last year of its brand new Schaefer stock system, Kärcher now holds in stock \$3.5 million in spare parts and accessories only (excluding machines), representing a total commitment to the service back up of its products.

A further point of support is its sales and service training facilities where it is possible to train in-house dealer sales and service personnel in all facets of technical and sales of Kärcher equipment.

For visitors from New Zealand, Kärcher Australia now has a successful sales branch in Auckland to solve cleaning problems in the New Zealand market.

Kärcher's range of cleaning equipment is impressive from domestic high pressure cleaners to industrial high pressure cleaners, vacuums spray extractions, sweepers and scrubbers plus a wide range of chemicals and accessories for every cleaning application, all of which will be on display at Exhibitors Show Case.

Kärcher personnel on the stand will be: David Sholson - Managing Director, Australasia; Susan Sholson - State Manager; Albert Manto - Area Manager.

K.E.W. Cleaning Systems

1/7 Cullen Place, Smithfield, NSW, 2164
Tel: (02) 725 5033

Southcott Pty Limited
243 Halifax Street, Adelaide, SA 5000

Tel: (08) 228 2411

STATE DISTRIBUTORS

Capital Equipment
8 Belmont Avenue, Belmont, WA 6101
Tel: (09) 479 1999

M&V Partridge Service Pty Ltd
6/14 Violet Street, Revesby, NSW 2212
Tel: (02) 771 3066

K.E.W. Cleaning Systems
22 Ferguson Drive, Underwood, QLD 4119
Tel: (07) 342 4566

KE.W. are one of the world's largest manufacturers of high pressure water cleaners.

They are ideally suited to the hire industry as they are very robust.

Units are available in 240 Volt and 415 Volt.

Four different petrol units are available from 3 H.P. through to 11 H.P. A heavy diesel driven unit is also extremely well suited to the industry.

Hot, cold and steam units are also available both in 240 Volt and 415 Volt. The heating cycle is one of the most efficient in the world, heating from tap temperature to 150 degrees C. in approximately 70 seconds.

The high pressure pumps are constructed from hot pressed brass with stainless steel pistons. The electric motors are all "F" class insulation.

Wet and dry vacuum cleaners are also available from light industrial to the more robust 40 and 80 litre heavy duty models.

All K.E.W. products are covered by a full 12 month warranty. Each state distributor has a comprehensive range of spare parts and can offer a full service facility if required.

See us at the Exhibition.

Kubota Tractor (Australia) Pty Ltd

110-112 Mahoney's Road, P.O. Box 156
Thomastown, VIC. 3064
Tel: (03) 462 2322 - Fax: (03) 462 2185

Kubota is Australia's foremost supplier of tractors to the agricultural market and is a market leader in the construction industry, where it maintains No. 1 position in the under 6 tonne class of hydraulic mini excavators. Kubota's range of articulated wheel loaders are also having a major impact in the construction equipment market place.

Following the success of the construction equipment in the newly formed Kubota Power Equipment Division,

marketing a range of horizontal stroke diesel engines, industrial air cooled petrol engines, petrol volume and trash pumps, diesel pumps, petrol and diesel generators (550W to 20,000W) and two models of diesel welder generators along with a full range of garden equipment.

On display will be a cross section of construction, garden and power equipment appropriate to the hire industry. Kubota and dealer staff will be present to answer any queries.

Lincoln Electric

35 Bryant Street, Padstow, NSW 2211
Tel: (02) 772 7222 - Fax: (02) 792 1387

216 Richmond Road, Marleston, SA 5033
Tel: (08) 43 8061 - Fax: (08) 234 0140

Townsville - (077) 79 9777
Mackay - (079) 51 2599
Brisbane - (07) 277 2955
Newcastle - (049) 52 8555
Wollongong - (042) 71 4777
Melbourne - (03) 562 1588
Launceston - (003) 26 5447
Perth - (09) 277 8744

Anyone looking to hire welding equipment which will easily fit into most workshop and field operations need look no further than the Lincoln Electric stand at this year's Hire Exhibition in Adelaide.

Even a glimpse at the stand will give visitors no doubt as the diversity of welders and consumables produced by Lincoln Electric Australia, leading arc-welding manufacturer.

Their stand will be constantly manned during the exhibition with personnel capable of offering expert advice on most welding applications.

The Lincoln Electric Company is no stranger to equipping workers on the move or organisations needing welders for special jobs.

For instance, Lincoln has long been ahead in the development of portable wire-feeders, such as their LN-25 which enable the operator to weld in places which most welders can not reach, such as work at great heights.

This welding innovation goes well with most Lincoln Electric semi-automatic welders, such as the compact new Australian-made MIG welder, Jetmig 195.

The 195 uses continuous wire electrode, yet can be operated from a three-pin 240v plug.

It can be easily moved on its four

Continued on page 101

From page 100

wheel trolley, which is fitted with an integral bottle rack and chain, with a regulator, flow meter and gas inlet hose supplied.

Another plus is that this small, mobile welder can be used with flux-cored 0.9mm NR211MP mild steel electrode to avoid the inconvenience of gas bottles and which is very suitable for outside welding in windy conditions. The unit handles both aluminium and stainless steel.

For simultaneous welding and supplementary power the go-anywhere Weldanpower range of motor driven welders are the answer as both a welder and an auxiliary power source.

For welding on-the-spot, the latest and quietest Weldanpower 275Q diesel models will easily fit on or into any utility.

The "quiet one" is described as three machines in one as it can provide AC power for stick electrode and DC power for continuous wire-feeding and other uses as well as generating 240volt, 50Hz power for standby or emergency use.

As a welder it handles 2.0mm to 4.0mm mild steel electrodes and can be used for stainless steel, cast iron or hardfacing to toughen those old parts.

As power generators go, Lincoln's low-speed Dis-gen range is about their most popular with hire companies and construction contractors.

It has a power range from 240v single phase 6.5kVA to 35kVA in single and 3-phase. Marine versions of the Dis-gen units are also available.

For major development sites and workshops, the 400AS-50 field welder popularly known as "the workhorse of the construction industry" is tipped to be a big drawcard at the Lincoln stand.

This diesel-powered machine features maximum arc stability, instant generator response to changing conditions at the arc, infinite variation of welding current and open-circuit voltage. All models supply auxiliary power for tools and lights.

Like all the Lincoln range, ease of operation and a long service life under demanding field conditions are built into these machines.

For specific details, just ask the man at the stand, or contact an office of Lincoln Electric Australia.

Makita (Australia) Pty Ltd

92 Wetherill Street, Siverwater, NSW 2141
Tel: (02) 748 3944 - Fax: (02) 748 4290

Makita, market leaders in power tools will be exhibiting their full range of power tools, which total in excess of 200 at the last count. This will be an ideal opportunity for hire companies to view tools and machines, and talk to the experts about their requirements.

Included in the range are a relatively new family of demolition and rotary hammers. Some recent releases include 380mm mitre saw, a new 255mm mitre saw, slide compound mitre saw, 2 speed industrial wet and dry vacuum, and several new and exciting cordless models.

Makita has nine branches around Australia, so wherever you come from, you can go back and contact your nearest branch regarding any spare parts or service requirements you may have.

M.I. (Australia) Pty Ltd

11 Plasser Crescent, St Marys, NSW 2760
Tel: (02) 833 1909

M.I. (Australia) Pty Limited is a subsidiary of Mark Industries USA providing the Marklift brand scissor lifts, boom lifts and knuckle booms to the Australian market. The Marklift brand is well known in Australia with machines in service here since 1978.

M.I. plans to exhibit the J-25 WEP scissor lift and the 30KBN knuckle boom. The J-25WEP features 90 degree steering with a push out deck extension in a 48" wide machine. The 30KBN (winner of the 1989 Plant Engineering Product of the Year Awards) features direct electric drive for outstanding gradeability and duty cycle at a maximum 36' working height and is only 48" wide. Gene Jones, Managing Director and Trevor Philpott, Victorian/S.A. Representative will be at the exhibition to discuss these as well as the 50 other models of Marklifts available.

Mole Engineering Pty Ltd

Address 38 Cavan Rd, Dry Creek 5094
P.O. Box 202 Dry Creek 5094
Tel: (08) 260 3277 - Fax: (08) 260 6377

Sydney: (02) 688 8011
Melbourne: (03) 305 4191
Brisbane: (07) 277 5744
Nth Queensland:(077) 79 8688
Perth: (09) 350 5410
Adelaide: (08) 260 3277
Hobart: (002) 34 6258

Kalgoorlie: (090) 21 3000
Darwin: Universal Diesels (089) 81 3852

The Whole Solution Suppliers of:

- Ditch Witch Trenches
- Stanley Hydraulic Equipment
- Hanomag Loader/Dozers
- Mitsubishi Graders
- I.H.I. Excavators
- Mikasa Compaction Equipment
- Pipe Line Equipment

Invite you to our display featuring:

- 1010 + 1620 Ditch Witch
- Stanley Hydraulic Tools
- Mikasa Rammers & Plates
- Pipe & Cable Locators

Ozone Manufacturing Pty Ltd

6 Howards Road, Beverley, SA, 5009
Tel: (08) 268 5401

Ozone supplies two products ranges for the Australian Hire and Rental Industry:

- Fume and dust extraction
- Portable cooling.

All products are manufactured in Australia with several made exclusively for the industry.

Fume extraction product:

- suitable for extracting from welding, cutting, soldering, vehicle exhaust, laboratory dust, etc.
- portable, 240 volt with filters, hoses or flexible arms to zero in on the source
- subject to rapidly increasing demand due to Occupational health and Safety legislation. Some companies are now recommending to customers that a fume extractor always be used in conjunction with welding machines.

Portable cooling products:

- for cooling of people, machines and products
- portable 240 volt designed for long life under Hire Industry conditions
- includes the unique mobile pedestal fan and box fan, both made for the hire industry
- also includes portable man coolers, wall fans and pedestal fans.
- To assist you at the exhibition will be: Phil Duke - fume and dust extraction specialist; Paul Hastings - portable cooling specialist.

Continued on page 102

Parklands Trading Co Pty Ltd

71 Chapel Street, NSW, Lakemba 2195
Tel: (02) 758 2111 - Fax: (02) 759 7844

15 Parkhurst Dve, Knoxfield, VIC, 3180
Tel: (03) 801 7711 - Fax: (03) 801 925

3/200 Balcatta Road, Balcatta, W.A.
Tel: (09) 344 4748 - Fax: (09) 345 3339

Parklands Trading have been importing the TAS-TANAKA range of power products for 22 years and firmly believe that "Tomorrows Tools For Todays Jobs" sums up the product range.

TAS-TANAKA are the oldest engine manufacturer in Japan being established over 70 years.

Parklands Trading have been a supporter of the Hire & Rental Association for some years now, and offer a range of equipment that has proven reliability, easy maintenance and a superb parts backup if needed.

Some of the items that will be on display at this years convention are:-

- Chainsaws - 7 Models
- Brush Cutters - 14 Models
- Petrol Driven Drills - 2 Models
- Earth Augers - 1 and 2 man
- Pumps - 2 Models
- Cut Off (Demolition) Saws
- Hedge Trimmers - 2 Models
- Lawn Edges - Gear Driven

For further details please contact our personell at our display.

Red Roo Mower Company Pty Ltd

54 Vanity Street, Toowoomba, Qld, 4350
Tel: (076) 34 2877 - Fax (076) 33 1915

J.A. Kerr III will man the booth at the show. On display at our booth will be the following:-

- RED ROO Slasher Model R 26
- RED ROO Slasher Model R 24
- RED ROO Edger
- RED ROO Out Front Slasher
- RED ROO are manufactures of commercial outdoor power equipment.

Sewer Equipment Company (Aust.)

11 Carrington Road, Marrickville, NSW 2204
Tel: (02) 559 5622-008

Present a comprehensive range of sewer and drain cleaning products from

ELECTRIC EEL with whom SECA have been proud to be associated for over 22 years. Included in the display will be manual, electric and petrol driven machines, plus the latest Kinetic Water Ram.

On hand to assist with your needs will be Kevin Quealy and George Rose, who have both been in the industry longer than either would care to admit.

Simon-Abbey Pty Ltd

98 Fairbank Rd, Clayton, VIC 3168
Tel: (03) 551 8866 - Fax: (03) 551 5723

NSW (02) 648 4199

WA (09) 350 6488

QLD (07) 277 3588

Simon-Abbey Pty Ltd is a subsidiary of Simon Access, a division of Simon Engineering plc.

Simon Access is the largest supplier of Access Equipment in the world with the most extensive product range.

Simon-Abbey based in Melbourne manufactures a range of truck mounted platforms and also distributes in Australia products from Simon's other Access businesses in Europe and the USA. The Group manufactures products ranging from ultra-light trailer mounted nine metre platforms to their well known 62 metre super snorkel for high reach applications as well as vehicle mounted digger derricks, truck mounted telescopic cranes, self-propelled telescopic and knuckle booms, self-propelled scissors tables and under bridge maintenance units.

Simon-Abbey takes its commitment to the Access Industry seriously. Combine that factor with Simon's aggressive worldwide approach to the development of innovative access equipment and it is obvious why Simon-Abbey is now well placed to service Australia's changing needs for electrical, industrial, construction and rental industry access equipment.

Some products Simon-Abbey are exhibiting are:-

- Boxer 140 - 14M self-propelled knuckle boom elevating platform featuring zero tailswing, a patented Simon concept
- Gofor 90 - 9M light weight trailer mounted platform. This unit is extremely compact and has a towing kerb weight of 500kg, for a one man basket capacity of 120kg
- Constructor AT40C - 14M self-propelled knuckle boom elevating platform featuring a true 4 x 4 rough terrain drive and zero tailswing
- A96IC Scissors - 9.6M industrial scissor

platform having a platform capacity of 680kg in any position, two speed drive and battery electric operation.

- L2034E Scissor - 7.9M general purpose "Z" configuration platform having a platform capacity of 315kg in any position, fold out extending deck, two speed drive and battery electric operation

Stihl Pty Ltd

2 Forbes Close, Knoxfield VIC 3180
Tel: (03) 765 1455 - Fax: (03) 764 2526

29 Lavarack Ave, Eagle Farm QLD 4007
Tel: (07) 268 6044 - Fax: (07) 868 1550

1 Hargraves Place,
Wetherall Park, NSW 2164
Tel: (02) 725 1155 - Fax: (02) 725 1387

Unit 3, 36 Birralee Road,
Regency Park, SA 5010
Tel: (08) 347 1515 - Fax (08) 347 1842

Malaga Commercial Centre
78 Irvine Drive, Malaga, WA 6062
Tel: (09) 249 3900 - Fax: (09) 249 4033

210 Wellington Street,
Launceston, TAS 7250
Tel: (003) 44 9522 - Fax: (003) 44 7890

38 Harris Road, East Tamaki,
Auckland New Zealand
Tel: (09) 274 5694 - Fax: (09) 274 8539

Stihl Pty Ltd will be exhibiting the following range of products:

- chainsaws
- brushcutters
- high pressure water cleaners
- industrial vacuum cleaners
- demolition saws
- earth augers
- blowers, and hedgecutters

All of these products are available throughout Australia and New Zealand via an extensive dealer network of 1,400 dealers who are serviced by Stihl branches.

All of these German-engineered products, which are renowned for their reliability and durability, are backed-up by a constant supply of spare parts and accessories available through our dealer network covering all areas of Australasia.

The Software Link Pty Ltd

P.O. Box 1 Berkeley Vale, NSW, 2259
Phone: (043) 88 5133 - Fax: (043) 88 5035

The Software Link Pty Ltd and its associates, with some 270 computer system installations for the Hire and

Continued on page 103

From page 102

Rental Industry in Australia claims to be the industry leader. With sites from Perth to Port Moresby and Auckland to Melbourne, Cairns and Brisbane, its leadership in the industry is not likely to be challenged for a long time to come!

It offers the industry a range of computer systems for all types of hire and rental businesses including plant hire, party hire, white goods electronic equipment hire, video hire, car and truck rentals and includes amongst its clientele companies such as Atomic Hire with an on-line system in three states through to Mosbi Hire in Boroko, Papua New Guinea, Oldfields Scaffold Hire in Auckland and Sydney, Hirepool with nine branches on the eastern coast of Australia, and many, many other users.

Displayed on the Software Link stand will be typical computer systems for your review and evaluation from single user basic back office systems through to multi user on-line systems. The Software Link offers a unique support facility for its clients regardless of where they are in Australia. The on-line support enables The Software Link support person to operate the client's computer whether in Perth or Port Moresby, Auckland or Melbourne just as if The Software Link's support person was in the hire company's office!

The Software Link's support person sees the screen and operates a keyboard of the customer's computer remotely, thereby eliminating all of the problems of support where the technician has to physically be in your office to fix the problem.

Help and support is available within a few seconds at any time during working hours!

The Software link will have a team of customer support staff and consultants on their stand, led by Chris Pannell - Managing Director - with over 25 years of experience in the Australian hire and rental industry.

Trilogy Business Systems Pty Ltd

100 Harris Street, Pymont, NSW 2009
Tel: (02) 692 8688
VIC - (03) 690 4000
QLD - (07) 371 6311

SA - (08) 234 2000
ACT - (06) 239 1650
WA - (09) 443 2722

The Trilogy "TRACS" system was released in Australia and New Zealand by Trilogy Business Systems in June 1989. The system has been written and designed specifically for the hire industry by people who both appreciate and understand the industry, it is designed to meet the needs of both small and large hire companies. The advanced Versyss Computer Systems technology enables TRACS to be the fastest contract processing system available in Australia.

TRACS can provide your business with an opportunity to be more efficient and productive, enabling you to give better service to your customers and thereby increase your profits by the use of a computer system. The system is currently being successfully used to great advantage in over 200 sites.

Trilogy provide comprehensive training and support through both our National and Branch support groups. We have a thorough implementation plan which is designed to ease your introduction to the system and ensure a successful installation.

We believe Trilogy, through TRACS, can make a valuable contribution to the hire industry. Trilogy maintains an awareness of the needs of the hire industry and will continue to improve the system to provide a better product and therefore a better service to your industry.

Vibmac Marketing Australia

3 Ellison Road, Geebung QLD 4034
Tel: (07) 8652220 - Fax: (07) 265 7014

Vibmac Marketing Australia has been involved with the Hire Industry for over 15 years now and are proud to be exhibiting at the Australian Hire Expo our proven products, which are as follows.

- TABLES: ABS Plastic Tables - virtually indestructible. Won't crack, splinter or warp.
- CHAIRS: Folding and stacking chairs. Innovative designs. Allows stacking like you have never seen in Australia before.

- PEDISTRIAN ROLLERS: Vibmac 760. The preferred and proven Pedestrian Roller.
- POST HOLE BORERS: Bormac. Totally hydrostatic Post Hole Borer gives operator complete control of auger. No Torque reaction. (Child's play).

Our people to see at the Exhibition will be: Neville J Brownlow - Chief Executive; Thomas J McCarthy - State Sales Manager; Terry Stewart - Vibmac New Zealand.

Viking Equipment (Aust) Pty Limited

P.O. Box 42, Moorebank, NSW 2170
Tel: (02) 602 3666 - Fax: (02) 60 13527
Toll Free (008) 112 428

361 King Street, Newtown, NSW 2042
Tel: (02) 550 3111
Toll Free: (008) 112 428

754 Beaudesert Road, Coopers Plains, QLD 4108
P.O. Box 326, Archerfield
Tel: (07) 275 1683

218 Princes Highway,
Dandenong, VIC 3175
Tel: (03) 793 1892 - Fax: (03) 794 0682
Toll Free: (008) 112 428

Viking Equipment (Aust) Pty Limited is a totally Australian enterprise committed to maintaining its position at the forefront of the industry with equipment renowned for reliability and performance, even under the most rigorous usage.

The Company has also long been direct in its technical efforts and resources towards the development and distribution of products which are environment-friendly.

Some of the products they are exhibiting are:

- **Genuine Gerni Turbo Laser High Pressure Water Cleaners**

Exclusive Gerni Turbo Laser gives up to seven times better cleaning performance than ordinary fan jet equipped pressure cleaners. Brass and stainless steel component materials are standard for long-life and reliability. Revolutionary Turbo Laser powered Gerni hot water machines really retain water temperature for faster, more efficient cleaning.

Advance Turbo Laser technology offers significant operator and environmental benefits including water saving, power and energy savings, low

Continued on page 104

From page 103

atomisation effect for greater operator health and safety, incredible time saving and dramatic reductions in waste water disposal demand.

- **Gerni Extra 10 and Extra 16**

- **Carpet/Fabric Shampoo Machines**

Gerni Extra Carpet/Fabric Shampoo machines have proven their value over and over with equipment rental companies. They're ideal for home use and can be actively promoted to restaurants, and small businesses for regular carpet maintenance care. Strong, reliable and lightweight are key features of the Gerni Extra.

- **Gerni Wet and Dry Vacuum Cleaners**

Gerni Wet and Dry Vacuum Cleaners completely remove wet sand, broken glass, ash, spillages, sink overflows - and are ideal for removing water from freshly washed floors for a safer, cleaner workplace. They are powerful, robust and light to carry. Features a huge 20 litre waste tank, offers continuous performance and does not overheat.

- **Hiretech Wallpaper Stripper**

This is a superb machine made for the hire industry. They do a first class job and are easy to use. The units are entirely self-contained so the user cannot lose parts. Key features are compact, reliable and portable.

- **Hiretech Disc Floor Edger**

These versatile machines give a score-free finish and are ideal for corners, small floors, stair-treads and bench tops. They are simple to use and offer solid reliability and trouble-free operation.

- **Hiretech Floor Sander**

Built to handle any job - large or small. A key feature is 'no bounce' so the operator can depend on a professional finish, even if a first-time user. Built tough to return your investment over and over.

- **Airlessco Airless Paint Sprayers**

Airlessco sprays most paint coatings quickly and efficiently with minimal overspray. Strength and quality design means continuous performance with low maintenance. The equipment is ideal for professional painters, do-it-yourselfers - particularly painting paling fences, steel and metal fabricators for

proof coating.

- **Greenpower Detergent**

Greenpower is a breakthrough in environment-friendly detergent technology. Available in a heavy duty cleaner, food area cleaner and for car/truck fleet washing applications. Specially blended so it's equally effective in both manual and pressure cleaning operations.

- **Cleantabs Detergents**

Environment-friendly Cleantabs 'tablet form detergents' can provide a range of cleaning detergent options - Carpet cleaners ideal for carpet shampoo machines, through to Wash and Wax for floors and cars. Each Cleantabs tablet represents the exact dosage for the job. No mess. No fuss. Cleantabs have proven their value and performance with the hire industry throughout Australia.

- **Water Recycle Equipment**

Toughening requirements towards waste water treatment before discharge into drainage will likely see a growing number of site works needing a new management approach to pollution control. Viking Equipment distribute 'new generation' compact, portable water treatment recycling systems for this purpose. Details available on request.

For enquiries and advice on Viking's products and services at the Exhibition contact Company Director, Jerry Krusza. Jerry is well known throughout the hire industry so you'll be talking to someone experienced with the products you hire and who understands what you are talking about.

Wacker Australia Pty Ltd

913 Princes Highway, Springvale VIC 3171
Tel: (03) 547 4033 - Fax: (03) 562 3371

Branches in Queensland, New South Wales, South Australia and West Australia. Distributors in Tasmania and Northern Territory.

WACKER construction equipment has been involved worldwide with compaction and vibration for over 50 years, offering a wide range of equipment for the industry.

- **Quick Cutting Saws:**

In 300 mm and 350 mm blade sizes, 70 cc and 95 cc respectively, 2-wheel trolleys with sprinkling kit and abrasive or diamond blades.

- **Hammer-Drills and Breakers:**

Electric or Pneumatic powered Ham-

mer-Drills suitable for drilling holes form 20mm to 50 mm and for concrete breaking. The Petrol Breaker is capable of replacing a 20 kg pneumatic breaker.

- **Rammers:**

Seven different models are available to suit compaction applications in trenches ranging from 100mm to 610mm or over and for different materials like clay, crushed rock, asphalt and earth.

- **Vibroplates:**

Petrol powered, light and powerful for soil compaction, asphalt patching and/or brick paving. Water kit and trolleys available.

- **Vibrating Rollers**

Walk behind Single Drum or Sheep-foot and ride-on Double Drum articulated/oscillating rollers available to suit compaction needs on earth, crushed rock, asphalt and clay.

- **Reversible Vibroplates:**

The ideal machines to replace large rollers in confined areas. Capable of compacting backfill lifts from 200mm to 750mm. Five models having up to 6.7t centrifugal force.

- **Concrete Vibrators:**

Available in 25mm, 40mm and 57 mm heads powered either by petrol or electricity via flexible shaft. Alternatively pneumatic or electric High Frequency Vibrators.

- **Pumps:**

Submersible flexible shaft or trash in 50mm and 75 sizes with capacities ranging from 35,000 to 100,000 litres/hour.

Westpoint Corporation Ltd

Private Bag 8, Panmure
Auckland, New Zealand
Tel: 0064 (09) 570 2511 - Telex Westcorp,
NZ 60883

We intend to display Gasmaster Industrial Air Heaters including new models and also Remington Industrial kerosene Heaters.

AUSTRALIAN AGENTS

Airdraulic Birco Group
3/3 Lancefield Place, Artamon NSW 2064
Contact: Stephen Murray
Tel: (02) 438 1025 - Fax: (02) 439 5636

Berwick Climate Control
2 Lonsdale Street, Dandenong VIC 3175
Contact: Chris Booth
Tel: (03) 791 4655 - Fax: (03) 794 6773

FUTURE DIRECTIONS

19TH INTERNATIONAL HIRE CONVENTION AND EQUIPMENT EXHIBITION

**Adelaide Convention Centre
Adelaide, South Australia**

SEPTEMBER 10-14, 1990

Invitation

The Hire & Rental Association of Australia S.A. Region Inc. is delighted to invite you to attend the 19th International Hire Convention and Equipment Exhibition.

Venue

The Convention and accompanying Trade Exhibition will be held in the Adelaide Convention Centre, Australia's first purpose-built facility and a pace-setter for all other such centres now in course of construction in other capital cities. The Centre's recently opened Exhibition Hall with its 3000 m² floor area will house a comprehensive industry-oriented Exhibition.

Convention Theme — "Future Directions"

The 19th International Hire Convention will focus on a vision for the future:

Member concerns—

- Where is your business headed?
- What problems are to be faced between now and the year 2000?
- How will you overcome these problems?
- What will be your future marketing direction?
- How will you identify the business opportunities?
- How can you assist your Association to exert more power on behalf of the industry?

Association concerns—

- How can it maximise its effectiveness in legislative areas?
- Is lobbying the answer?

These are just some of the issues that will be addressed with a view to helping your business to operate even more successfully into the second millenium. There will be ample opportunity for your opinions to be heard through interactive workshop and forum situations. However, if there are specific topics you would like to see included within the formal programme, please don't hesitate to notify us when sending in your completed Registration Form.

Professional speakers, advisors and lateral thinkers will both inspire and educate. All sessions will centre on the Hire and Rental Industry.

Yard Tours

Arrangements are well in hand with member organisations for visits to a diverse range of yard tours.

Social Programme

Those members who came to Adelaide during its Jubilee Year (1986) will remember with affection the calibre of South Australian hospitality. We are looking forward to making you even more welcome in Adelaide during the 1990 Convention.

PROGRAMME

(Subject to change)

MONDAY SEPTEMBER 10, 1990

- 2.00pm-7.30pm Early Registration (Main Foyer, Adelaide Convention Centre)
4.00pm-5.00pm International Cocktails, overseas delegation (Hyatt Regency Adelaide)
5.30pm-7.00pm Early Registrants' Mystery Tour followed by:
7.00pm-10.00pm South Australian Welcome (Non-registrant Guest Tickets \$40)

TUESDAY SEPTEMBER 11, 1990

- 8.00am-7.30pm Registration and Information Desk Open (Adelaide Convention Centre)
9.00am-1.00pm Yard Tour (for early arrivals) including morning tea
10.00am-1.00pm Yard Tour B, including morning tea
1.00pm-9.00pm Trade Exhibition Open (Adelaide Exhibition Hall)
1.00pm-2.30pm Lunch adjacent to Trade Exhibition (Non-registrant Guest Ticket \$20)
2.30pm-6.00pm Continuous Coffee in Trade Exhibition Area
2.00pm-5.00pm Registered Accompanying Persons' Excursion:
Adelaide Hills/Rooftop Clothing Workshop (Non-registrant Guest Ticket \$30). Scenic drive to visit Rooftop Designers' Workshop. See centuries-old printing technique resulting in beautiful garments. Includes afternoon tea.
6.00pm-9.00pm Official Reception incorporating Official Opening of Trade Exhibition (Non-registrant Guest Tickets \$30)
9.00pm-10.30pm Optional City Lights Tour and 'Nightcap' (\$25)

WEDNESDAY SEPTEMBER 12, 1990

- 8.00am-6.00pm Registration and Information Desk Open (Adelaide Convention Centre)
2.00pm-6.00pm Trade Exhibition Open (Adelaide Exhibition Hall)
9.00am-5.00pm Registered Accompanying Persons' Excursion:
(Non-registrant Guest Tickets \$60)
A Day on the Farm (including morning and afternoon tea and lunch)
Travel scenic coast route south through the Fleurieu Peninsula to a Hereford Stud breeding bulls for the modern cattle producer. Visit the holiday resort townships of Victor Harbor and Goolwa before calling into Malleebaa Woolshed for a sheep shearing demonstration. See beautifully hand-crafted garments. Homeward route passes through picturesque Hills townships including Strathalbyn where once a year the internationally acclaimed Penny Farthing Bicycle Race takes place.
9.00am Welcome Address
Keynote Address
9.15am Marketing Beyond 2000: Yourself; Your Business; Your association
Speaker: The Hon. John Brown, Businessman and former Minister for Sport, Recreation and Tourism, now Chairman of the Tourism Task Force
10.00am Challenging the Future and Benefiting from New Opportunities: Financial Implications of Current Government Actions
Speaker: Dr Neville Norman, Senior Economic Adviser to the Committee for Economic Development of Australia and Economic Counsellor to the Australian Institute of Management
11.00am Coffee Break
11.30am The Canberra Scene: The Lobbyist's Role
Speaker: David Barnett, former Press Secretary to Malcolm Fraser, when Prime Minister of Australia; now Political Writer for "The Bulletin"
12.15pm Panel Discussion/Questions/Summing Up: Brown/Norman/Barnett
12.30pm Lunch (Non-registrant Guest Ticket \$20)
Guest Speaker: Dr Peter Steidl, Austrian Consul
2.00pm-6.00pm Visit Trade Exhibition—
Coffee and Tea Available
5.00pm-6.00pm Happy Hour in Trade Exhibition Area
Free Night, or your choice of the following optional programme:

- 7.30pm-10.30pm Three-course Dinner at L'Entrecote Brasserie to an accompaniment of Gypsy Violins (\$25 excluding wines) and/or
 9.00pm-12.00am Private Blackjack Tournament, Adelaide Casino (\$25) (Limited to 94 participants)

THURSDAY SEPTEMBER 13, 1990

- 8.00am-5.30pm Registration and Information Desk Open
 8.00am-11.30am Trade Exhibition Open—Continuous Coffee available
 9.30am-12.30pm Half Day Function for Registered Accompanying Persons
 Fortune Cookies & More — at Hyatt Regency Adelaide (Non-registrant Guest Ticket \$30). Most people are fascinated with Numerology, Astrology, Palm Reading, Tarot Cards and Crystal Balls! Here is the opportunity you've been waiting for. Intending participants can enclose details of their FULL NAME, including MAIDEN SURNAME (if applicable), date, place and time of birth in a sealed envelope, with name clearly written on the outside, and we will provide this to the experts for advance evaluation. A delightful morning tea is included.
- 10.00am Entertainment Hire Seminar:
 Profit in Pleasure
 Panel of speakers, co-ordinated by Bob Curkpatrick, Renniks Hire
- 11.30am Morning Coffee
 11.45am FORUM:
 Harnessing the Power of Your Association
 Speakers will include Members of the Hire & Rental Association, a Retired Politician and a Public Relations expert.
 Moderator: Lois Grant, Human Resources Consultant
- 1.00pm Lunch (including Registered Accompanying Persons) incorporating Debate by the South Australian Debating Society on the topic:
 "Only Fools Hire Equipment" (Non-registrant Guest Ticket \$25)
- 2.30pm-5.00pm Optional Guided Boutique Shopping Excursion for Accompanying Persons (\$35 including afternoon tea)
- 2.15pm-5.00pm FUTURE DIRECTIONS WORKSHOP
 Using the latest video and audio techniques, Lois Grant skilfully leads participants through an interactive workshop which provides the opportunity for everyone to build on the morning Forum. It will highlight the need to co-operate to achieve results, help identify problems and provide solutions. Ways to achieve personal growth—Association growth—business growth through a positive outlook and lateral thinking will also be explored.
- 7.15pm-1.00am FUTURE DIRECTIONS GRAND BALL
 (Hyatt Regency Adelaide)
 Theme: "Putting On The Ritz"
 Pre-Ball drinks precede the 19th International Hire & Rental Association Convention Ball—truly a night to remember! (Non-registrant Guest Ticket \$75)

FRIDAY SEPTEMBER 14, 1990

- 10.00am-6.00pm "FUTURE DIRECTIONS" BAROSSA VALLEY EXCURSION (\$65)
 Highlight include: Wine Tasting; Kevin Rohrlach Museum, Tanunda; Excellent Lunch; Great Wines; Jazz; and much, much more! One coach will depart in time to take delegates directly to the Airport to catch early evening flights to Melbourne and Sydney (luggage kept on coach during the day).

A stimulating, innovative social programme has been put together for both delegates and accompanying persons. We have put together an interest-filled One Day Post-Convention Excursion to the world-renowned Barossa Valley—the largest wine-producing area in Australasia. Plan to stay that extra day. Those of you who can spare more time, particularly our overseas participants, we invite to spend a weekend on Kangaroo Island to enjoy more of Australia's unique flora and fauna. Another alternative is to take a flying trip into the Outback—to Australia's Red Centre, but calling in at Coober Pedy's Opalfields on the return journey. Why not extend your stay in South Australia? Plan to coincide a holiday with family members. We will be delighted to help you with any 'add-on' itinerary.

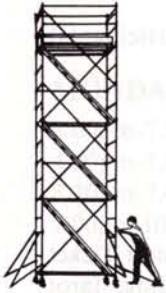

ALSCAF PTY LTD

Incorporated in NSW

Aluminium Scaffolding Specialist

2/82 COSGROVE ROAD, STRATHFIELD SOUTH, N.S.W. 2136

- ★ ADVANTAGES —
- ★ PRICE
- ★ 2.6mm WALL THICKNESS TUBE
- ★ 60% MORE ALUMINIUM FOR YOUR MONEY
- ★ EVERY FRAME A BASE FRAME
- ★ ROBUST IN CONSTRUCTION
- ★ ADJUSTABLE OR SLIP-ON CASTORS
- ★ FRAME HEIGHTS 1M & 1.5M

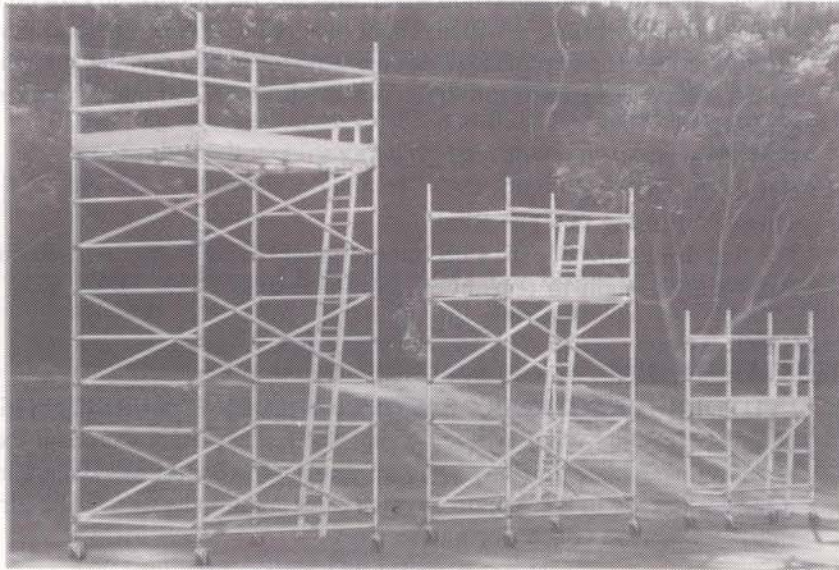

SALES or HIRE
Ph. (02) 642 6533

Feroza proves a budget gem in tough outback role

Daihatsu Feroza has tamed the rugged country.

Lightning Ridge, the tough opal mining centre in the far north of New South Wales is home to a Daihatsu duo in a new role. The outback opal town is a tourist mecca as overseas and local adventurers visit, all looking for the ultimate opal, the unique black opal found only in Lightning Ridge.

Until recently the only public transport has been local buses and tour operators. Now the Lightning Ridge Budget Rent-a-car agent, and Shell Service Station, has a pair of Daihatsu Feroza 4WDs, and the tough new Daihatsu leisure oriented Ferozas have proven a popular addition to a growing hire car fleet.

Part of a trio ordered by Bathurst Budget operator, Les Tickell, the soft top Ferozas are used by tourists, opal buyers and even the locals to visit some of the out of town haunts of the tough

opal town.

The Daihatsu Feroza is proving popular in the hire car role. Already more have been ordered interstate for similar duties and further orders are expected for other New South Wales rural areas too.

The economical 4WD is an excellent fleet vehicle. Maintenance costs are kept low with a 16 valve, 1.6 litre fuel injected engine linked to a five speed gearbox.

Modern styling and a choice of soft top or hard top models with a variety of interior trim further offers operators a custom package.

The Lightning Ridge Budget Ferozas are soft top models, joined in Dubbo, by a hard top Feroza. The Daihatsu 4X4s spend the majority of their life on some mighty tough roads. Ruts, washouts and ripples are the order of the day - extensive flooding in the local areas recently has made conditions even tougher than

normal.

Daihatsu's new and sophisticated suspension for Feroza irons out the worst of the roads. A strong chassis and sturdy construction will see the Ferozas stand up to the worst local conditions which include a wide variety of wild life varying from kangaroos to wild brumbys.

Reliability has been excellent.

The "Ridge" Budget operator, Jim Devlin, says change-over from customer to customer is as easy as filling the tank and washing out the local red dust and mud.

The Feroza hire-4WDs have become popular local identities, attracting further orders for Daihatsu. The first person who hired the Budget Feroza wanted to keep it!

Daihatsu Feroza has also been selected as the official media liaison vehicle for the Redex Variety Club Bash - Bourke to Broome, presently under way across Australia.

The 712 Contractor Lift

SUMNER

- Lifts 550 pounds, 12 feet
- New auto-lock carriage latch
- Sumner-built winch
- Telescoping masts
- Legs/forks fold for easy transportation

The job-site tough 712 Contractor Lift is built for a wide range of material handling requirements. Using telescoping masts made of high grade steel, the 712 Lift handles large 550 pound loads up to 12 feet. The heart of this powerful lift is a rugged Sumner designed and built winch that assures the operator of safe, effortless operation.

An exclusive 712 highlight is the auto-lock carriage latch system that secures forks in the lowered position when tilting or transporting the unit. When the lift is upright, the latch unlocks automatically and the 712 is ready to go to work.

Add to this Sumner's unique feature of folding legs and load forks (patent pending) which allows the 712 to fit into most minivans and some station wagons!

The total of these features, plus a price to meet all budgets, makes the Sumner 712 the 12 foot material lift for all contractors.

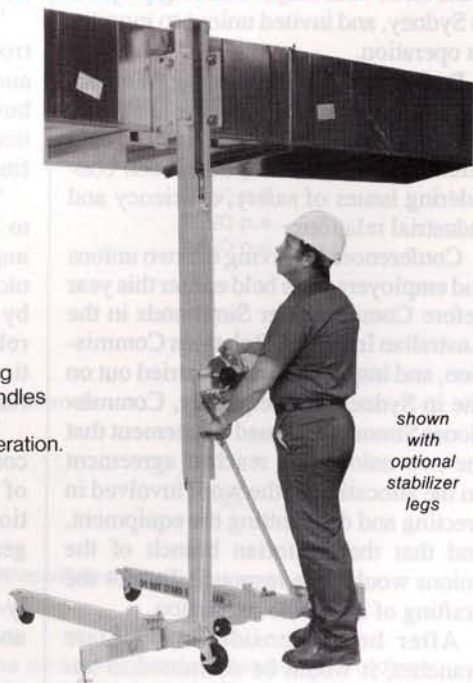

shown with optional stabilizer legs

Sales & Service By:

Horizon Access Spares & Service Pty. Ltd.

(Incorporated in N.S.W.)

P.O. Box 437, Ingleburn 2565. Phone (02) 829 1277 (24 Hrs). Fax (02) 618 3632

National Standards for Mast Work Platforms

Agreement has been reached between employers and two major building industry unions on developing a national standard for the use of mast-climbing work platforms in the building and construction industry.

The move paves the way for nationwide use of the new equipment, which is an alternative to traditional scaffolding and swing stages. Mast work platforms are extensively used overseas, with more than 2,500 units operating throughout Europe and the United States. The new technology was introduced in Australia last year by Hi-Climber Rentals, which now has 18 mast-climbing systems valued at \$1.95 million ready for hire.

Hi-Climber Rentals trialed the equipment on several major building projects in Sydney, and invited unions to monitor its operation.

Both the BWIU (Building Workers Industrial Union) and the FEDFA (Federated Engine Drivers and Firemen's Association) have been considering issues of safety, efficiency and industrial relations.

Conferences involving the two unions and employers were held earlier this year before Commissioner Simmonds in the Australian Industrial Relations Commission, and inspections were carried out on site in Sydney. Subsequently, Commissioner Simmonds issued a statement that the two unions had reached agreement on the allocation of the work involved in erecting and dismantling the equipment, and that the Victorian branch of the unions would take responsibility for the drafting of a suitable regulation.

After being considered by State branches, it would be submitted to appropriate authorities for inclusion in local Acts or regulations.

Commissioner Simmonds said that in the meantime, the equipment could continue to be used, provided there was con-

sultation between its owners or hirers and the unions, with appropriate safety standards being adopted pending formal regulation and certification.

Managing Director of Hi-Climber Rentals, Bob Howison, said he was delighted with the outcome of the talks in the Industrial Relations Commission.

"Potential users of this equipment can now feel confident a national standard will be completed in the near future," Mr Howison said.

"It is never easy to introduce new practices and technology to the building industry, particularly when they are from overseas.

"Matters which have to be addressed include import procedures, technical approvals on a state by state basis, industrial relations, safety practices and award coverage for users.

"Hi-Climber Rentals set out to overcome the difficulties and prove the value of this equipment to the local construction industry and to the economy in general.

"We welcome the move for nationally-adopted guidelines on the operation and use of mast climbing platforms."

Mr Howison said companies who had already made use of the equipment agreed it provided a safe and efficient solution to many of the access challenges in construction and renovation projects.

"Hi-Climber platforms offer a safe

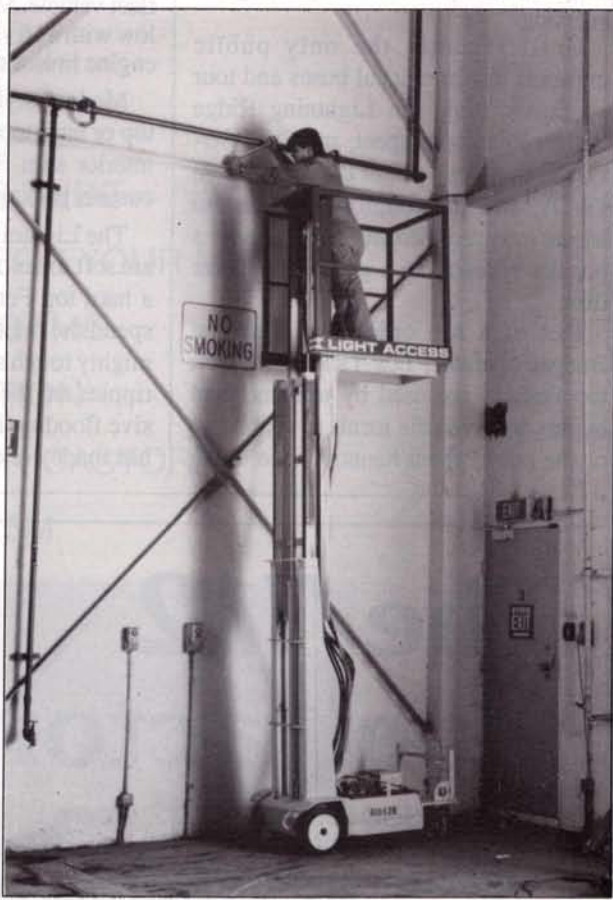

The Hi-Climber system in operation at 139 Macquarie Street.

working platform for employees, materials and tools," he said.

"They can be positioned at infinitely variable heights to reduce the bending and stretching needed with conventional access systems.

"This improves safety, reduces fatigue and improves the quality of the finished work."

Hi-Climber are exclusive distributors for the world's Leading range of platforms designed and manufactured by HEK Construction Equipment, Holland.

HIRE ASSOCIATION OF NEW SOUTH WALES

MEMBERSHIP APPLICATION FORM

P.O. Box 613
BAULKHAM HILLS 2153
PH: 634 2964
Fax: 899 3419

* MUST BE COMPLETED IN FULL *

COMPANY NAME

ADDRESS (Street) P.O. BOX NO.

SUBURB POSTCODE

PHONE FAX

CONTACT PERSON POSITION

2ND CONTACT PERSON POSITION

COMPANY SIZE (Circle appropriate) SMALL MEDIUM LARGE

DESCRIPTION OF TYPE OF HIRE List sub groups

..... plus space for 'other'

DESCRIPTION OF SUPPLY OR SERVICE (ASSOC)

LENGTH OF TIME IN HIRE BUSINESS

STAMP DUTY NUMBER

50% OF INCOME IS DERIVED FROM HIRE YES/NO (Delete one that does not apply)

AMOUNT OF HIRE INCOME FROM UNRELATED BUSINESSES %

TO: Secretary
Hire Association NSW
P.O. Box 613
Baulkham Hills 2153

I wish to apply for membership of the Hire Association of NSW as a FULL/ ASSOCIATE (Delete whichever does not apply) Member.

Enclosed is my cheque for \$

SCALE OF H.A.N.S.W. FEES:

CITY

COUNTRY (Less 20%)

* Entrance Fee (Once Only)	\$100	
* Annual Turnover up to \$500,000	\$200	\$160 p.a.
* Annual Turnover \$500,001 - \$1.5M	\$300 p.a.	\$240 p.a.
* Annual Turnover \$1.5M - \$5M	\$400 p.a.	\$320 p.a.
* Annual Turnover over \$5M	\$500 p.a.	\$400 p.a.
* Associate Members (Suppliers)	\$250 p.a.	
* Interstate Members	\$ 75 p.a.	
* International Members	\$125 p.a.	
* Company Branches (Optional)	\$ 20 per address	

= @ \$20 per branch

Branch Address:

Contact Person: Ph: Fax:

* DEFINITION OF COUNTRY AREAS:

Country members are those whose business is outside the greater Sydney Metropolitan area.

I, of

desire to become a member of the H.A.N.S.W., and request you enter my name on the Register of Members accordingly, subject to your Memorandum of Articles of Association.

Dated this day of 19

Signed

ADVERTISERS INDEX

Name	Page	Name	Page
Advanced Power Products Pty Ltd	24	Kango Australia Pty Ltd	43
AETCO	62	Karcher Pty Ltd	49
Aggreko Generators	45	Kawasaki Motors Pty Ltd	27
Austoft Industries Limited	ISBC	Komatsu (Aust) Pty Ltd	41
Australian Brick Cleaning Co	52	Kubota Tractor (Aust) Pty Ltd	22-23
Bay Textiles Ltd	71	Lincoln Electric Company (Aust) Pty Ltd	57
B.P. Australia	48	Lister Petter Aust Pty Ltd	13
Bianco Builders Hardware	60	Makita (Aust) Pty Ltd	26
Briggs & Stratton Australia Pty Ltd	36	M.I. (Aust) Pty Ltd	29
J.I. Case	37	Midcomp Pty Ltd	78
Clark Equipment Australia Limited	25	Migomag Industries	83
Compair (Australasia) Ltd	41	Mole Engineering Pty Ltd	28
Cranford Products	79	Namco Furniture	33
CRC (Aust) Pty Ltd	39	Noblet & Forrest Pty Ltd	16
Deck Guardrail Systems Pty Ltd	Insert	No-Bolt Scaffolding Pty Ltd	54
Dembicon Australia	87	OAMPS International	4
Dunlite Power Generators	50	Oldfields Pty Ltd	61
Easymix	64	Parklands Trading Co Pty Ltd	17
Electric Eel Aust Pty Ltd	51	Prestige Portables Pty Ltd	80
Elliservice Convention Management	Insert	Quinns Canvas Goods Pty Ltd	73
Flexible Pipe-Cleaning Tools	Insert	Roads Signs	53
Flextool (Aust) Pty Ltd	56	Simon-Abbey Pty Ltd	18
Form-It Fibre Glass Formwork Pty Ltd	76	Suncorp Finance Ltd	47
Form-Quip Australia Pty Ltd	78	The Software Link Pty Ltd	ISFC
Hansen & Sykes Pumps	63	Trade Structures Pty Ltd	67
Hitachi Sales (Aust) Pty Ltd	21	Transmission Technology Pty Ltd	55
Hoecker Structures (Aust) Pty Ltd	72	Trilogy Business Systems	19
Honda Power Equipment	Insert	Troltip Australia Pty Ltd	59
Horizon Access Spares & Services Pty Ltd	86	Tutts machinery	42
Ingersol Rand (Aust) Ltd	14	Viking Equipment (Aust) Pty Ltd	81
Instant Scaffolds	34	Viking Equipment (Aust) Pty Ltd	84
Intrac (Sales) Pty Ltd	77	Vivacity Pty Ltd	69
Jaden Pty Ltd	44	Westpoint Corporation	52
Johnson & Couzins (SI) Ltd	40	Westwood Engineering Australia Pty Ltd	58



From Australia's leading manufacturer of cane harvesting equipment comes a range of tough, reliable road rollers and trenchers. Mustang, by AUSTOFT.

MUSTANG MUSCLE.

From 7.4 horsepower through to 30+ horsepower, Mustang rollers have the muscle to handle the toughest jobs.

Choose from a host of different weights, rolling widths and capacities – all with the service muscle of the AUSTOFT dealer network.

A. Mustang Tandem Roller. B. Mustang 2-75P Double Drum Roller. C. Mustang TR20 Trencher.

D. Mustang TR14 Mini Trencher. When you want rollers and trenchers that can handle the rough stuff, you want Mustang muscle.

Ask an Austoft dealer today, or phone (071) 53 1077 for a free brochure.

Manufactured by:

AUSTOFT INDUSTRIES LIMITED
PO Box 932 Bundaberg Qld 4670
Fax (071) 53 1797



New from
CompAir

Whether it's Large Units

Compair Holman 900 - 100S

900 c.f.m. of air at 100 p.s.i.

Features include

- Auto - shut down protection.
- All round access for easy maintenance
- "Supply on demand" automatic control of engine speed
- Silenced all steel enclosures
- Suitable for built up areas
- 180° turntable steering

Major Construction
Projects
Mining/Quarrying
Sand Blasting



Construction Projects
Under Road Boring
Mining
Sand Blasting



Smaller Units

Zitair 400A

400 c.f.m. of air at 100p.s.i.

Features include:

- Automatic shut down protection
- Fully silenced
- Single 2" outlet and 4 independent 3/4" outlets.
- All steel canopy.

Government Depts.
Construction &
Road Works
Water Scouring



Small Units

Zitair 175A

175 c.f.m. of air at 100 p.s.i

Features include:

- Automatic shut down protection
- "Gull wing" doors for increased access and ease of service.
- Fully silenced - suitable for built up areas
- All steel canopy.

All do a **BIG** job

 **CompAir**
Versatile Power in Industry

COMPAIR (AUSTRALASIA) LTD.
HEAD OFFICE
34-40 Ricketts Road, Mt. Waverley 3149
Phone 544 0777 Fax 543 8759

ADELAIDE Lot 20 Kenworth Rd, Gepps Cross. 5094 Ph: (08) 349 4100
BRISBANE 1 Success St, Archerfield. 4108 Ph: (07) 275 2022
BROKEN HILL 184 Gaffney St, Broken Hill. 2880 Ph: (080) 88 3344
BURNIE Lot 5 Fairlands Estate, West Somerset, Burnie. 7320
Ph: (004) 35 1100
CANNING Woodlawn Mine, Tarago. 2580 Ph: (048) 44 6252
COBAR 20 Railway Parade Sth, Cobar. 2835 Ph: (068) 36 3344

DARWIN Lot 2146 Hardy Rd, Berrimah N.T. 0828 Ph: (089) 32 2662
HOBART 17 Pearl St, Moonah. 7009 Ph: (002) 72 3911
KALGOORLIE 149 Boulder Rd, Kalgoorlie. 6432 Ph: (090) 21 1588
MELBOURNE 71 Ricketts Rd, Mt Waverley. 3149 Ph: (03) 544 1755
MOUNT ISA 9-11 Commercial Rd, Mount Isa. 4825 Ph: (077) 43 6399

NEWCASTLE Heather St, Heatherbrae, Newcastle. 2324 Ph: (049) 83 1600
PERTH 7 Winton St, Kewdale. 6105 Ph: (09) 353 2522
ROXBY DOWNS 46 Charlton Street, Olympic Dam. 5725
Ph: (086) 71 0019
SYDNEY 4 Harbord St, Granville. 2142 Ph: (02) 637 8200
TOWNSVILLE 661 Ingham Rd, Townsville. 4817 Ph: (077) 74 6488

19TH INTERNATIONAL HIRE CONVENTION AND EQUIPMENT EXHIBITION

ADELAIDE CONVENTION CENTRE, ADELAIDE, SOUTH AUSTRALIA
FUTURE DIRECTIONS — SEPTEMBER 10-14, 1990

REGISTRATION FORM

Please complete this form and forward it together with payment in favour of FUTURE DIRECTIONS CONFERENCE to Ellisservice Convention Management, PO Box 753, Norwood SA 5067, Australia. Remittances from overseas should be by Bank Draft in Australian currency drawn on an Australian Bank. Credit Cards cannot be accepted.

REGISTRANT

REG'N No. _____

ORGANISATION _____

SURNAME _____ INITIALS _____ MR/MS/OTHER _____

CORRESPONDENCE ADDRESS _____

_____ P/CODE _____ COUNTRY _____

PHONE (incl. Area Code) _____ FAX _____

PREFERRED NAME FOR NAMEBADGE _____

NAME OF HIRE ASSOCIATION OF WHICH A MEMBER _____

ACCOMPANYING PERSON(S)

1. SURNAME _____ INITIALS _____ MR/MS/OTHER _____

PREFERRED NAME FOR NAMEBADGE _____

2. SURNAME _____ INITIALS _____ MR/MS/OTHER _____

PREFERRED NAME FOR NAMEBADGE _____

TRAVEL DETAILS (if known)

ARRIVAL _____ / _____ / 90 TIME _____ hrs FLIGHT _____ OTHER FORM OF TRANSPORT _____

DEPART _____ / _____ / 90 TIME _____ hrs FLIGHT _____

SPECIAL DIETARY/DISABILITY REQUIREMENTS (please advise) _____

ACCOMMODATION

I shall be making my own arrangements ()

Please arrange accommodation for adult(s) and child(ren)

Date in _____ / _____ / 90 Date Out _____ / _____ / 90 (by 10.00am).

Please prepay an accommodation deposit equivalent to two nights' accommodation.

	SINGLE	DOUBLE	TWIN	TRIPLE	SUITE
Hyatt	() @ \$165	() @ \$165	() @ \$165	() @ \$195	() @ \$275
Grosvenor					
• Business	() @ \$ 99	() @ \$113	() @ \$113	—	—
• Budget	() @ \$ 54	() @ \$ 68	() @ \$ 68	—	—

I WOULD LIKE TO SHARE ACCOMMODATION with the following person(s) whose form(s) is/are enclosed with this form:

Name(s) _____

TRADE EXHIBITOR/SPONSORSHIP OPPORTUNITY

Please send me details of Trade Exhibition () &/or Sponsorship Opportunities ()

We suggest you keep a photocopy of this form (both sides!) for your records.

PAYMENTS

\$

REGISTRATION FEES

- Member of any Hire Association – \$450 – Full Registrant
- Person(s) Accompanying a Full Registrant – Person(s) @ \$300 each

ACCOMMODATION DEPOSIT, 2 nights at the rate applicable to the hotel of your choice

CONFERENCE FUNCTIONS

(Free to Full Registrants & Registered Accompanying Persons, but please indicate if you will attend)

- | | | | | | | |
|----|---|----------|-----|------------------|-------------|-----------|
| IC | International Cocktails (Overseas Delegates) | Delegate | [] | Regd Acc.Persons | [] [] [] | No charge |
| MT | Mystery Tour & South Australian Welcome | Delegate | [] | Regd Acc.Persons | [] [] [] | No charge |
| MG | Non-registered Guests ticket(s) @ \$40 | | | | | |
| YA | Yard Tour A (Early Arrivals) | Delegate | [] | Regd Acc.Persons | [] [] [] | No charge |
| YB | Yard Tour B | Delegate | [] | Regd Acc.Persons | [] [] [] | No charge |
| AH | Adelaide Hills/Rooftop Clothing Workshop | | | Regd Acc.Persons | [] [] [] | No charge |
| AG | Non-registered Guests ticket(s) @ \$30 | | | | | |
| OR | Official Reception, Adelaide Convention Ctre | Delegate | [] | Regd Acc.Persons | [] [] [] | No charge |
| OG | Non-registered Guests ticket(s) @ \$30 | | | | | |
| DF | A Day On The Farm | | | Regd Acc.Persons | [] [] [] | No charge |
| DG | Non-registered Guests ticket(s) @ \$60 | | | | | |
| FC | Fortune Cookies and More! | | | Regd Acc.Persons | [] [] [] | No charge |
| FG | Non-registered Guests ticket(s) @ \$30 | | | | | |
| | Envelope(s) enclosed with personal details – birthdate, full names, maiden surname, etc. (Indicate Qty) | | | | | |
| RB | Future Directions “Putting On The Ritz” Ball | Delegate | [] | Regd Acc.Persons | [] [] [] | No charge |
| RG | Non-registered Guests ticket(s) @ \$75 | | | | | |
| TL | Tuesday Lunch | Delegate | [] | | | No charge |
| TG | Non-registered Guests ticket(s) @ \$20 | | | | | |
| WL | Wednesday Lunch | Delegate | [] | | | No charge |
| WG | Non-registered Guests ticket(s) @ \$20 | | | | | |
| HL | Thursday Lunch | Delegate | [] | Regd Acc.Persons | [] [] [] | No charge |
| HG | Non-registered Guests ticket(s) @ \$25 | | | | | |

OPTIONAL FUNCTIONS

- CL City Lights Tour & ‘Nightcap’ ticket(s) @ \$25
- DL Dinner at L’Entrecote Restaurant ticket(s) @ \$25
- PB Private Blackjack Tournament at Adelaide Casino ticket(s) @ \$25
- BS Boutique Shopping (Guided) ticket(s) @ \$35
- BV Barossa Valley ‘Future Directions’ Excursion ticket(s) @ \$65

POST-CONVENTION EXCURSIONS (\$100 deposit per person payable with this form, balance due August 1, 1990)

Children’s prices advised on confirmation of reservation.

- AR Ayers Rock/Cooper Pedy (Opals & The Outback) ticket(s) @ \$100 deposit each
- Adult(s) Child(ren)
- KI Kangaroo Island ticket(s) @ \$100 deposit each
- Adult(s) Child(ren)

TOTAL NOW DUE AND PAYABLE TO “FUTURE DIRECTIONS CONFERENCE” \$

OFFICE USE ONLY

Hotel _____

CRS _____

Ack _____

Remarks _____

CONVENTION SECRETARIAT

Elliservice Convention Management
 PO Box 753, Norwood SA 5067
 or
 60 Kensington Road
 Rose Park SA 5067
 Australia
 Phone: (08) 332 4068
 Fax: (08) 364 1968

FUTURE DIRECTIONS

**19TH INTERNATIONAL
HIRE CONVENTION
AND
EQUIPMENT EXHIBITION**

**ADELAIDE CONVENTION CENTRE
ADELAIDE, SOUTH AUSTRALIA**

SEPTEMBER 10--14, 1990

**INVITATION TO REGISTER
(Separate Registration Form Enclosed)**

**AUSTRALIAN
AIRLINES**



FUTURE DIRECTIONS

19TH INTERNATIONAL HIRE CONVENTION & EQUIPMENT EXHIBITION

Adelaide Convention Centre
Adelaide, South Australia

SEPTEMBER 10-14, 1990

Invitation:

The Hire & Rental Association of Australia S.A. Region Inc. is delighted to invite you to attend the 19th International Hire Convention and Equipment Exhibition.

Venue:

The Convention and accompanying Trade Exhibition will be held in The Adelaide Convention Centre, Australia's first purpose-built facility and a pace setter for all other such centres now in course of construction in other capital cities. The Centre's recently-opened Exhibition Hall with its 3000m² floor area will house a comprehensive industry-oriented Exhibition. At the time of going to print with this brochure, a few 3m² areas are available and your enquiries will be welcomed.

Convention Theme – "Future Directions"

The 19th International Hire Convention will focus on a vision for the future:

Member concerns:

- Where is your business headed?
- What problems are to be faced between now and the year 2000?
- How will you overcome these problems?
- What will be your future marketing direction?
- How will you identify the business opportunities?
- How can you assist your Association to exert more power on behalf of the industry?

Association concerns:

- How can it maximise its effectiveness in legislative areas?
- Is lobbying the answer?

These are just some of the issues that will be addressed with a view to helping your business to operate even more successfully into the second millenium. There will be ample opportunity for your opinions to be heard through interactive workshop and forum situations. However, if there are specific topics you would like to see included within the formal programme, please don't hesitate to notify us when sending in your completed Registration Form.

Professional speakers, advisors and lateral thinkers will both inspire and educate. All sessions will centre on the Hire and Rental Industry.

Yard Tours:

Arrangements are well in hand with member organisations for visits to a diverse range of yard tours.

Social Programme:

Those members who came to Adelaide during its Jubilee Year (1986) will remember with affection the calibre of South Australian hospitality. We are looking forward to making you even more welcome in Adelaide during the 1990 Convention.

REGISTRATION FORM

Please complete the Registration Form accompanying this brochure. Pre-registration is recommended and full payment of the appropriate registration fee, accommodation deposit, optional social programme and non-registrant guest selections should accompany completed Registration Form.

KEYNOTE SPEAKERS

The Hon. John Brown

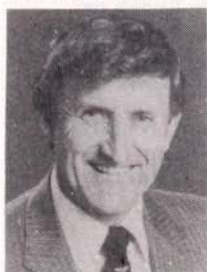

Dr Neville Norman



PROGRAMME

subject to change

- 2.00pm-7.30pm Early Registration (Main Foyer, Adelaide Convention Centre)
4.00pm-5.00pm International Cocktails, overseas delegation (Hyatt Regency Adelaide)
5.30pm-7.00pm Early Registrants' Mystery Tour followed by:
7.00pm-10.00pm South Australian Welcome (Non-registrant Guest Tickets \$40)

TUESDAY SEPTEMBER 11, 1990

- 8.00am-7.30pm Registration & Information Desk Open (Adelaide Convention Centre)
9.00am-1.00pm Yard Tour A (for early arrivals) including morning tea
10.00am-1.00pm Yard Tour B, including morning tea
1.00pm-9.00pm Trade Exhibition Open (Adelaide Exhibition Hall)
1.00pm-2.30pm Lunch adjacent to Trade Exhibition (Non-registrant Guest Ticket \$20)
2.30pm-6.00pm Continuous Coffee in Trade Exhibition Area
2.00pm-5.00pm Registered Accompanying Persons' Excursion:
Adelaide Hills/Rooftop Clothing Workshop (Non-registrant Guest Tickets \$30)
Scenic drive to visit Rooftop Designers' Workshop. See centuries-old printing technique resulting in beautiful garments. Includes Afternoon Tea.
6.00pm-9.00pm Official Reception incorporating Official Opening of Trade Exhibition (Non-registrant Guest Tickets \$30)
9.00pm-10.30pm Optional City Lights Tour & 'Nightcap' (\$25)

WEDNESDAY SEPTEMBER 12, 1990

- 8.00am-6.00pm Registration & Information Desk Open
(Adelaide Convention Centre)
- 2.00pm-6.00pm Trade Exhibition Open
(Adelaide Exhibition Hall)
- 9.00am-5.00pm Registered Accompanying Persons'
Excursion:
(Non-registrant Guest Tickets \$60)
A Day on the Farm (including morning and
afternoon tea and lunch)
Travel scenic coast route south through the
Fleurieu Peninsula to a Hereford Stud
breeding bulls for the modern cattle
producer. Visit the holiday resort townships
of Victor Harbor and Goolwa before calling
into Malleebaa Woolshed for a sheep
shearing demonstration. See beautifully hand-
crafted garments. Homeward route passes
through picturesque Hills townships including
Strathalbyn where once a year the
Internationally-acclaimed Penny Farthing
Bicycle Race takes place.
- 9.00am Welcome Addresses
Keynote Addresses
- 9.15am Marketing Beyond 2000: Yourself; Your
Business; Your Association.
Speaker: The Hon. John Brown,
Businessman and former Minister for Sport,
Recreation & Tourism, now Chairman of the
Tourism Task Force
- 10.00am Challenging the Future and Benefitting from
New Opportunities: Financial Implications of
Current Government Actions.
Speaker: Dr Neville Norman, Senior
Economic Adviser to the Committee for
Economic Development of Australia &
Economic Counsellor to the Australian
Institute of Management
- 11.00am Coffee Break
- 11.30am The Canberra Scene: The Lobbyist's Role.
Speaker: David Barnett, former Press
Secretary to Malcolm Fraser, when Prime
Minister of Australia; now Political Writer
for The Bulletin
- 12.15pm Panel Discussion/Questions/Summing Up:
Brown/Norman/Barnett
- 12.30pm Lunch (Non-registrant Guest Ticket \$20)
Guest Speaker Dr Peter Steidl,
Austrian Consul
- 2.00pm-6.00pm Visit Trade Exhibition —
Coffee and Tea Available
- 5.00pm-6.00pm Happy Hour in Trade Exhibition Area
Free Night, or your choice of the following
optional programme:
- 7.30pm-10.30pm 3-Course Dinner at L'Entrecote Brasserie to
an accompaniment of Gypsy Violins (\$25
excluding Wines) &/or
- 9.00pm-12.00am Private Blackjack Tournament, Adelaide
Casino (\$25) (Limited to 84 participants)

THURSDAY SEPTEMBER 13, 1990

- 8.00am-5.30pm Registration & Information Desk Open
- 8.00am-11.30am Trade Exhibition Open —
Continuous Coffee available
- 9.30am-12.30pm Half Day Function for Registered
Accompanying Persons
Fortune Cookies & More — at Hyatt
Regency Adelaide
(Non-registrant Guest Ticket \$30)
Most people are fascinated with Numerology,
Astrology, Palm Reading, Tarot Cards and
Crystal Balls! Here is the opportunity you've
been waiting for. Intending participants can
enclose details of their FULL NAME,
including MAIDEN SURNAME (if
applicable), date, place and time of birth in a
sealed envelope, with name clearly written on
the outside and we will provide this to the
experts for advance evaluation. A delightful
morning tea is included.
- 10.00am Entertainment Hire Seminar:
Profit in Pleasure
Panel of speakers, co-ordinated by
Bob Curkpatrick, Renniks Hire
- 11.30am Morning Coffee
- 11.45am FORUM:
Harnessing the Power of Your Association.
Speakers will include Members of the Hire &
Rental Association, a Retired Politician and
a Public Relations Expert.
Moderator: Lois Grant,
Human Resources Consultant
- 1.00pm Lunch (including Registered Accompanying
Persons) incorporating Debate by the South
Australian Debating Society on the topic:
"Only Fools Hire Equipment".
(Non-registrant Guest Ticket \$25)
- 2.30pm-5.00pm Optional Guided Boutique Shopping
Excursion for Accompanying Persons (\$35
including afternoon tea)
- 2.15pm-5.00pm FUTURE DIRECTIONS WORKSHOP
Using the latest video and audio techniques,
Lois Grant skilfully leads participants
through an interactive workshop which
provides the opportunity for everyone to
build on the morning Forum. It will highlight
the need to cooperate to achieve results, help
identify problems and provide solutions.
Ways to achieve personal growth —
Association growth — business growth
through a positive outlook and lateral
thinking will also be explored.
- 7.15pm-1.00am FUTURE DIRECTIONS GRAND BALL
(Hyatt Regency Adelaide)
Theme: "Putting On The Ritz"
Pre-Ball Drinks precede the 19th
International Hire & Rental Association
Convention Ball — truly a night to remember!
(Non-registrant Guest Ticket \$75)

FRIDAY SEPTEMBER 14, 1990

10.00am-6.00pm **"FUTURE DIRECTIONS" BAROSSA VALLEY EXCURSION (\$65)**

Highlights include: Wine Tasting; Kevin Rohrlach Museum, Tanunda; Excellent Lunch; Great Wines; Jazz; and much, much more! One coach will depart in time to take delegates directly to the Airport to catch early evening flights to Melbourne and Sydney (luggage kept on coach during the day).

A stimulating, innovative social programme has been put together for both delegates and accompanying persons. We have put together an interest-filled One Day Post-Convention Excursion to the world-renowned Barossa Valley — the largest wine-producing area in Australasia. Plan to stay that extra day. Those of you who can spare more time, particularly our overseas participants, we invite to spend a weekend on Kangaroo Island to enjoy more of Australia's unique flora and fauna. Another alternative is to take a flying trip into the Outback — to Australia's Red Centre, but calling in at Coober Pedy's Opalfields on the return journey. Why not extend your stay in South Australia? Plan to coincide a holiday with family members. We will be delighted to help you with any 'add-on' itinerary.

POST-CONVENTION EXCURSIONS

AR ADELAIDE/AYERS ROCK/COOBER PEDY/ADELAIDE

(Sat. Sept. 15-Tues. Sept. 18, 1990)

Aust. \$1,028 per person (twin/share basis), Aust. \$1,309 per person (single room occupancy) Prices correct as at May 1, 1990

Opals and the Centre! Go outback in a hurry! Fly out of Adelaide to Alice Springs. Travel to Ayers Rock. 2 nights at Sheraton Ayers Rock Hotel with plenty of time to climb the world's largest monolith and observe its unique colour changes at dusk and dawn. En route to Adelaide call into Coober Pedy — see opals being mined, cut and polished. Buy this fiery gem at source if you wish. Overnight literally 'down under' in the underground Desert Cave Motel. Includes all transfers between airports and hotels.

KI ADELAIDE/KANGAROO ISLAND/ADELAIDE

(Sat. Sept. 15-Sun. Sept. 16, 1990)

Aust. \$278 per person (twin/share basis), Aust. \$348 per person (single room occupancy) Prices correct as at May 1, 1990

Whaling history, Australian wildlife, spectacular views and rock formations are all to be found on Kangaroo Island. Observe sealions at close proximity at Seal Bay and have lunch with kangaroos and other friendly Australian native animals at Flinders Chase National Park. Visit Remarkable Rocks and Cape de Couedic. Includes all transfers between airports, jetties and hotels, lunch and dinner on Saturday and breakfast and lunch on Sunday.

A deposit of \$100 per person is required for each Excursion. The balance must be paid on or before August 1, 1990. Full itinerary will be sent with acknowledgment of registration. Tickets will be available at the Convention Registration Desk.

ACCOMMODATION

Accommodation has been reserved at two hotels both of which are close to the Adelaide Convention Centre. The group discount rates set out below are on a 'room only' basis. Children's rates will be advised on request. Delegates are responsible for payment of their accommodation accounts less prepaid deposit (if any) on check out.

Hyatt Regency Adelaide, (adjacent to the Adelaide Convention Centre), North Terrace, Adelaide.
Telephone 08.231.1234

- Single, Double or Twin Room — \$165, Triple \$195
- Executive Suite/Hospitality Suite — \$275
comprises Kingsized bedroom, Ensuite Bathroom & Lounge. An interconnecting Double or Twin Room can be reserved at the additional charge of \$165 should a corporate group wish to avail themselves of the Hospitality facility.

Grosvenor Hotel, (opposite to the Adelaide Convention Centre), 125 North Terrace, Adelaide.
Telephone 08.231.2961

Business Class:

- Single Room \$ 99
- Double or Twin Room \$113

Budget Class:

- Single Room \$ 54
- Double or Twin Room \$ 68

ACCOMMODATION DEPOSITS

All requests for accommodation must be accompanied by prepayment of two nights' accommodation at the hotel of your choice. Ellisservice Convention Management will not guarantee to hold accommodation unless this payment is made. Delegates will forfeit their accommodation deposit in all instances where rooms have been reserved but are not used unless formal notification of later arrival has been received by Ellisservice at least seven days prior to the booking commencement date. Accommodation will be allocated strictly in order of receipt of registration forms.

Special Group Rates

The rates quoted are specially discounted for the Convention and must be booked through the Convention Registration Form. Delegates wishing to share must indicate this on the Registration Form. All persons involved must indicate this on their individual Registration Forms. To avoid confusion, it is recommended that all such Registration Forms be enclosed in the same envelope. Ellisservice is unable to arrange shared accommodation with unspecified participants.

Sponsorships

A hallmark of previous Hire & Rental Conventions has been the generous support of the membership. We look forward to involving as many members as possible in high profile sponsorship areas. A list of possibilities has been prepared and will be forwarded upon request.

REGISTRATION FEES & ENTITLEMENTS

\$450 Full Registrant (applicable to Members of any Hire Association).

Inclusions:

All Business Sessions, Yard Tours, Trade Exhibition, Conference Satchel, Working Papers, Morning & Afternoon Coffee or Tea, Lunches, Mystery Tour & South Australian Welcome, Official Reception and Future Directions "Putting On The Ritz" Ball.

\$300 Person Accompanying a Full Registrant.

Inclusions:

Yard Tours, Trade Exhibition, Lunch on Thursday, Mystery Tour & South Australian Welcome, Official Reception, Future Directions "Putting On The Ritz" Ball and the following Excursions:

Tuesday - Adelaide Hills/Rooftop Clothing

Wednesday - A Day On The Farm

Thursday - Fortune Cookies & More!

CANCELLATION POLICY

Notification of cancellation of registration must be received in writing by letter or fax. A cancellation fee of \$75 will be charged in all instances where written notification of cancellation is received not later than August 1, 1990. The fee for cancellations received after that date will be not less than \$100 but may be in excess of that amount if the Convention is penalised by its external contractors. Ellisservice Convention Management will endeavour to negotiate the best possible refund on behalf of delegates who, due to circumstances beyond their control, find it necessary to cancel at the last minute.

CONVENTION & EXHIBITION ORGANISATION

All enquiries regarding the Convention, accommodation, trade exhibition or sponsorships should be directed in the first instance to Mrs Muriel Ellis, Ellisservice Convention Management, PO Box 753, Norwood, S.Australia 5067, Australia. Telephone 08 332 4068, Fax 08 364 1968.

AUSTRALIAN AIRLINES

The committee has appointed Australian Airlines the official airline for the Convention in recognition of valuable contributions made by Australian Airlines. It is important you support this appointment by flying Australian Airlines wherever air travel within Australia is required. If you are booking your travel through a travel agent, make sure your agent contacts Australian Airlines' Convention Travel Department for exactly the same reasons.

Adelaide	216 1312	Launceston	32 9911
Alice Springs	50 5233	Melbourne	829 2103
Brisbane	233 2266	Newcastle	26 1544
Cairns	50 3769	Perth	323 8427
Canberra	46 1816	Sydney	669 9555
Darwin	82 3380	Townsville	81 6233
Gold Coast	38 1066	Wollongong	29 9411
Hobart	38 3333		

HONDA
POWER EQUIPMENT

Honda Range.



Honda: of ideals and innovation

A company's products not only present its "face" to the public, but its "soul" or guiding philosophy as well. And nowhere is this more manifest than in the case of Honda. For by virtue of its distinctive, award-winning products, Honda has come to be regarded by many as a bold symbol of vitality, as the very embodiment of innovation itself. The impetus behind the activities of Honda is a determination to challenge the established limits that bind other corporate entities to the commonplace—be they limits on technology, on originality, or on the capacity of men and women to grow and progress. And while this resolution to cast aside the conventional and aim for the exceptional is determinedly irrevocable, it is by design flexible enough to allow the exploration of fresh, singular ideas, ideas that provide excitingly creative and ingeniously practical solutions to society's needs.

Three distinct yet mutually supportive pillars that rise above the routine.

The Honda of today is a dynamic, multifaceted company devoted to the production of three major product lines; motorcycles, automobiles and power products. Though each is deservedly noted for excellence in its own right, all three quite naturally share a number of important aspects, the most obvious of which is leading-edge engine technology. But while the level of Honda's expertise is distinctly superior from a pure research and development standpoint, it is of course the thoughtful and successful application of its technological know-how



that clearly sets Honda apart from its competitors. Be it in the motorcycle, automotive or power equipment field, Honda has demonstrated an extraordinary ability to shape and refine pure, advanced technology in order to meet specific needs in a most efficient way.

Quality borne of exclusive facilities and an exacting attention to detail.

To facilitate the development of original technology and products, Honda provides its engineers with a work environment in which they have total freedom of expression, the freedom to explore the very limits of technological achievement. With regard to corporate structure, this has been accomplished by giving complete autonomy to the individual research and

development centres for Honda motorcycles, automobiles and power equipment. The Honda R & D Asaka East Centre, for example, is engaged exclusively in the development of power equipment; its activities embrace not only the design of general purpose engines, but also all of the various aspects related to products such as tillers, lawn mowers, riding mowers, lawn tractors and so on. Engine designs are oriented both to the in-house needs of



Honda, and to the many special requirements of original equipment manufacturers (OEMs).

Raising quality assurance to the level of a precise science.

Every Honda product is fashioned using the most sophisticated facilities available, such as those in service at Honda's Hamamatsu Factory, where most of the company's power equipment is manufactured. But while advanced equipment such as robots and so on plays an important role in production, it is the fostering of human resources that enables the economic and efficient manufacture of high quality products. As part of the comprehensive quality control system that regulates all activities at every Honda equipment facility around the world, Honda associates have the opportunity to improve on existing equipment—or even create new types of equipment—by drawing on their own knowledge and expertise. The resultant enhanced quality of Honda equipment, in turn, helps the company meet its pledge of supplying products of the highest quality at a reasonable price.



HONDA
POWER EQUIPMENT

General Purpose Honda Engines

When it comes to engine and technological expertise, Honda simply has no equal in the field of power equipment. All Honda research activities are conducted in accordance with the pursuit of six particular attributes:

- Reliability Powerful output
- Economy Light weight Compactness
- Easy starting

These six benefits have come to exemplify Honda 4 stroke engine technology at its best, and they are of course at the heart of the great popularity of Honda lawn & garden products.



G100-
a 2.2HP* horizontal-shaft side valve light-weight engine (83cm³). Includes Automatic Decompression, mechanical governor and electronic ignition, suitable for edgers, pumps and small mowers.



GX110-
a 3.5HP* OHV horizontal-shaft light-weight engine (107cm³). Includes Automatic Decompression and Oil Alert suitable for edgers, pumps, small construction equipment and reel-type mowers.



GXV120-
a 4HP* OHV vertical-shaft engine (118cm³) with electronic ignition. Suitable for lawn mowers and a variety of industrial applications.



GX140-
a 5HP* OHV horizontal-shaft engine (144cm³) with electronic ignition and Oil Alert. Suitable for powering air compressors, generators, pumps, pressure washers, reel-type lawn mowers, and other construction equipment.

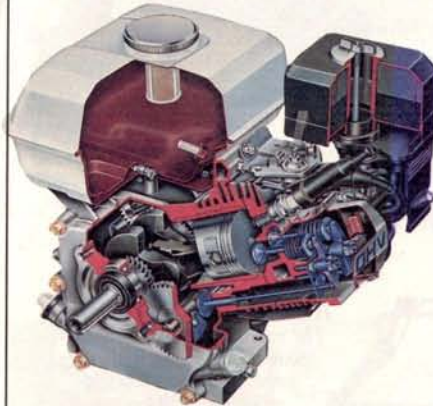

GX240-
an 8HP* OHV horizontal-shaft engine (242cm³) with electronic ignition and Oil Alert. Suitable for powering cement mixers, air compressors, water pumps, tillers and grain augers as well as many other construction applications.



GXV270-
an 8.5HP* OHV vertical-shaft engine (270cm³) with electronic ignition, easy maintenance features and Oil Alert. Suitable to run riding mowers, floor buffers and a variety of industrial applications.

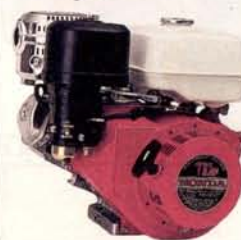

GX340-
an 11HP* OHV horizontal-shaft engine (337cm³) with 25 degree tilted cylinder, Oil Alert, electronic ignition, available with varying shaft and reduction ratios. Suitable for generators, pressure washers and a variety of construction equipment.

DIRECT INJECTION DIESEL ENGINES

As only Honda can make them. The ultimate in versatile power.



SPECIFICATIONS GD320-
Rated Output (HP/RPM): 6/3,600
Max torque (kgm/RPM): 1.6/2,500
Fuel Capacity (l): 4.6
Oil Capacity (l): 1.15
Dry Weight (kg): 48
(LxWxH-mm) 420x405x470
Fuel g/HP-Hr: 180



SPECIFICATIONS GD410-
Rated Output (HP/RPM): 8/3,600
Max torque (kgm/RPM): 2.1/2,500
Fuel Capacity (l): 4.6
Oil Capacity (l): 1.25
Dry Weight (kg): 54
(LxWxH-mm) 440x405x490
Fuel g/HP-Hr: 178



GXV340-
an 11HP* OHV vertical-shaft engine (337cm³) with easy-maintenance features, Oil Alert, and electronic ignition. Suitable for powering slashers, turf equipment and ride on mowers.



GXV390-
a 13HP* OHV air cooled, single cylinder engine (389cm³) with electric start. Suitable for power carriers, similar tasks and ride on mowers.



GV400-
an 11HP* vertical-shaft engine (406cm³) with electronic ignition. Suitable for a variety of industrial applications especially ride on mower power.

SPECIFICATIONS	G100	GX110	GXV120	GX140	GXV160	GX240	GXV270	GX340	GXV340	GXV390	GV400
Rated Output (HP/RPM):	1.5/3,600	2.7/3,600	2.9/3,600	3.8/3,600	4.1/3,600	6.0/3,600	6.3/3,600	8.2/3,600	8.2/3,600	9.0/3,600	8.2/3,600
Rated Torque (kgm/RPM):	0.38/3,000	0.7/2,500	0.82/2,700	1/2,500	1.1/2,500	1.7/2,500	1.8/2,500	2.4/2,500	2.3/2,500	2.8/2,500	2.45/2,500
Fuel Capacity (l):	1.4	2.5	1.0	2.5	2.0	6.0	2.0	6.5	2.3	2.3	2.3
Oil Capacity (l):	0.45	0.6	0.6	0.6	0.65	1.1	1.1	1.1	1.1	1.1	1.2
Dry Weight (kg):	8.5	12	12.5	14	15.5	23.5	28	31	32	33	33.5
(LxWxH-mm)	270x270	320x345	375x330	330x365	435x345	385x420	410x385	390x450	430x385	430x385	425x435
	x340	x320	x335	x335	x355	x410	x405	x435	x410	x410	x415
Fuel (g/HP-Hr):	320	230	250	230	250	230	240	230	230	230	270

*Maximum output

Honda Lawnmowers



HT-R3811

An 11 horsepower mower with a 38" cutting width, and automatic clutch. Oil alert system is fitted and an optional grass catcher is available. 5 speed plus reverse. *Optional catcher shown



HT3813

A 13 horsepower shaft drive mower, with a liquid cooled engine and 38" cutting width. Automatic clutch. A fuel gauge and coolant temperature warning light are fitted. Optional grass catcher available. 5 speed plus reverse.



HT4213

A 13 horsepower shaft drive mower with a liquid cooled engine and 42" cutting width. Automatic clutch. A fuel gauge and coolant temperature warning light are fitted. 5 speed plus reverse.

Honda introduced its first lawnmower model, the HR21, back in 1978.

And over the years, Honda's lineup has grown to include a range of models, both in push type and Ride-Ons. All built on Honda's legendary quality and 4 stroke power.



HRU194

A lightweight, easy to start (recoil) 4 stroke with OHV engine and aluminium deck. 11 cutting heights and 19" width.



HRA216

The 'commercial' self-propelled mower built for extra heavy duty service, easy start, 6 height adjustments, 21" cutting width, 2.0 litre fuel tank and easy to remove grass catcher. Includes rotorstop.



HR214SR

The ultimate 'self-propelled' mower - Easy start, 7 height adjustments, wide 21" cut and 'one touch removable' grass catcher bag.

SPECIFICATIONS	HR214SR	HRU194	HRA216
Engine:	GXV120	GXV120	GXV160
Cutting Width:	530mm (21")	470mm (19")	530mm (21")
Height Adjustment:	4 levers	1 lever	4 levers
Cutting Height Range:	13-76mm, (7 stages)	16-76mm (11 stgs)	18-67mm, (6 stgs)
Self Propelled System:	Positive gearshaft	N/A	Positive gearshaft
Self Propelled Speed:	L = .8m/sec H = 1.2m/sec	N/A	L = 1.2m/sec H = 1.65m/sec
Grass Bag Capacity:	73 litre	54 litre	73 litre
Fuel Tank Capacity:	1.0 litre	1.0 litre	2.0 litre
Dry Weight:	43.5kg	33.5kg	53kg
Dimens: (LxWxH-mm):	1700 x 570 x 1070	1410 x 410 x 1005	1670 x 565 x 1020



SPECIFICATIONS

	HT4213	HT3813	HT-R3811
Engine:	GX360	GX360	GXV340
Max. Horsepower:	13HP/3,600 RPM	13HP/3,600 RPM	11HP/3,600 RPM
Starter:	Electric (12V DC)	Electric (12V DC)	Electric (12V DC)
Air Cleaner:	Dual	Dual	Dual
Fuel Tank Capacity:	71L	71L	2L
Transmission:	MAT (Mechanical Autoclutch Transmission)	MAT (Mechanical Autoclutch Transmission)	MAT (Mechanical Autoclutch Transmission)
Traction Drive:	Propeller shaft drive from engine to transmission	Propeller shaft drive from engine to transmission	Belt and gear
Traction Clutch:	Dry type		Wet type, multi-plate
Speed (km/h):	1st (1.8) 2nd (2.3) 3rd (3.3) 4th (5.1) 5th (8.6) Rev (2.9)	1st (1.8) 2nd (2.3) 3rd (3.3) 4th (5.1) 5th (8.6) Rev (2.9)	1st (2.1) 2nd (3.7) 3rd (5.7) 4th (7.0) 5th (7.9) Rev (2.6)
Tyres (Front):	15 x 6.00-6	15 x 6.00-6	11 x 4.00-5
(Rear):	18 x 8.50-8	18 x 8.50-8	16 x 6.50-8
Cutter Deck:	Triple blades	Twin blades	Twin blades
Cutting Width:	107 cm (42")	97 cm (38")	97 cm (38")
Cutting Height:	19-102mm, 7 positions	19-102mm, 7 positions	19-82mm, 6 positions
Height Adjustment:	Single lever with indicator	Single lever with indicator	Single lever with balancer spring
Dimensions LxWxH:	1,755mm x 1,445mm x 1,056mm	1,755mm x 1,260mm x 1,045mm	1,535mm x 1,260mm x 1,000mm
Wheelbase:	1,160mm	1,160mm	1,100mm
Dry Weight:	257kg	252kg	177kg
Optional Grass Bag:	N/A	Available	Available

Honda Generators



Almost all electrical appliances can be run from a generating set, providing it has sufficient capacity. It is necessary to calculate the number of watts required to be used at one time. Light globes are simple to calculate because the wattage is marked on each but many appliances only carry an AMPS figure on the compliance plate. To convert AMPS to WATTS, multiply AMPS by VOLTS. eg: To calculate the wattage required for an appliance marked 5 AMPS:
 $5 \text{ AMPS} \times 240 \text{ VOLTS} = 1200 \text{ WATTS}$.
 Therefore, the generator required must have an output of no less than 1200 Watts. *Important Note:* Remember, that some appliances with electric motors may require up to 6 times the rated current draw just to start the motor. You should always consult your appliance's manufacturer for starting current draw before buying any generator.



EX350-
 72 Watt/12 Volt DC.
 Output 300
 Watt x 240 Volt AC.
SUPER LIGHT
 Quiet 2-stroke motor
 (34.4cm³)-ONLY
 8.5kg Powers
 Battery Charger,
 small T.V. etc.



EG1900X-
 Output 1700
 Watt x 240 Volt AC.
 144cm³ OHV 4-
 stroke. Suitable for
 powering Small
 Radiator, Circular
 Saw, Frypan and
 similar.



EG4500X-
 Output 4000
 Watt x 240 Volt AC.
 337cm³ 4-stroke.
 Suitable for powering
 Clothes Dryer, larger
 Heater, Hot Water
 Service, and similar.



EX650-
 Super quiet-100
 Watt/12 Volt DC, 550
 Watt x 240 Volt AC.
 76cm³ 4-stroke.
 Suitable for powering
 Lighting, T.V, small
 Fridge and similar.



EM1900X-
 100 Watt/12 Volt
 DC. Output
 1700 Watt/240 Volt
 AC. 144cm³ OHV 4-
 stroke. Suitable for
 Jug, Frypan, Iron,
 Small Radiator and
 similar.



EX5500-
 Output 5000 Watt x 240 Volt AC.
 359cm³ liquid cooled OHC 4-Stroke.
 Suitable for larger applications such as
 Arc Welding, House boat auxiliary power.



EX1000-
 Light weight (26kg)-
 100 Watt/12 Volt DC,
 850 Watt x 240 Volt
 AC. 98cm³ 4-stroke.
 Suitable for powering
 multiple Lighting,
 Television, Power
 Drill and similar.



EB3000X-
 Output 2800
 Watt x 240 Volt AC.
 292cm³ OHV 4-
 stroke. Suitable for
 powering Clothes
 Dryer, Dishwasher,
 most Hot Water
 Services and similar.

SPECIFICATIONS	EX350	EX650	EX1000	EG1900X	EM1900X	EB3000X	EG4500X	EX5500	APPLICATIONS																																						
Fuel Tank Capacity (l):	0.81	2	3.1	3.7	11.0	17.0	7.0	16.5	Approximate current draw in WATTS of commonly used electrical appliances is: <table border="1"> <thead> <tr> <th>APPLIANCE</th> <th>AVERAGE REQUIREMENT</th> </tr> </thead> <tbody> <tr> <td>Refrigerator (Element type)</td> <td>100-300W (Running)</td> </tr> <tr> <td>Dishwasher</td> <td>1000-2500W (Running)</td> </tr> <tr> <td>Hot Water Service</td> <td>2500-3500W</td> </tr> <tr> <td>Washing Machine</td> <td>500-2500W (Running)</td> </tr> <tr> <td>Food Mixer</td> <td>150W (Running)</td> </tr> <tr> <td>Kettle or Electric Jug</td> <td>1500W</td> </tr> <tr> <td>Can Opener</td> <td>100W (Running)</td> </tr> <tr> <td>Radio</td> <td>60W</td> </tr> <tr> <td>Radiator</td> <td>1000-2400W</td> </tr> <tr> <td>Stove</td> <td>7000-10000W</td> </tr> <tr> <td>Exhaust Fan</td> <td>40W (Running)</td> </tr> <tr> <td>Garbage Disposal Unit</td> <td>650W (Running)</td> </tr> <tr> <td>Clothes Dryer</td> <td>2400W (Running)</td> </tr> <tr> <td>Vitamiser</td> <td>450W (Running)</td> </tr> <tr> <td>Toaster</td> <td>1300W</td> </tr> <tr> <td>Iron</td> <td>1000W</td> </tr> <tr> <td>TV Set</td> <td>100-180W</td> </tr> <tr> <td>Vacuum Cleaner</td> <td>700W (Running)</td> </tr> </tbody> </table>	APPLIANCE	AVERAGE REQUIREMENT	Refrigerator (Element type)	100-300W (Running)	Dishwasher	1000-2500W (Running)	Hot Water Service	2500-3500W	Washing Machine	500-2500W (Running)	Food Mixer	150W (Running)	Kettle or Electric Jug	1500W	Can Opener	100W (Running)	Radio	60W	Radiator	1000-2400W	Stove	7000-10000W	Exhaust Fan	40W (Running)	Garbage Disposal Unit	650W (Running)	Clothes Dryer	2400W (Running)	Vitamiser	450W (Running)	Toaster	1300W	Iron	1000W	TV Set	100-180W	Vacuum Cleaner	700W (Running)
APPLIANCE	AVERAGE REQUIREMENT																																														
Refrigerator (Element type)	100-300W (Running)																																														
Dishwasher	1000-2500W (Running)																																														
Hot Water Service	2500-3500W																																														
Washing Machine	500-2500W (Running)																																														
Food Mixer	150W (Running)																																														
Kettle or Electric Jug	1500W																																														
Can Opener	100W (Running)																																														
Radio	60W																																														
Radiator	1000-2400W																																														
Stove	7000-10000W																																														
Exhaust Fan	40W (Running)																																														
Garbage Disposal Unit	650W (Running)																																														
Clothes Dryer	2400W (Running)																																														
Vitamiser	450W (Running)																																														
Toaster	1300W																																														
Iron	1000W																																														
TV Set	100-180W																																														
Vacuum Cleaner	700W (Running)																																														
Continuous Operating Hrs:	3.0(150VA)	4.7(50HZ)	3.9	3.5	10.7	9.5	3.0	5.5																																							
Noise Level: (dB-A/7m)	50(150VA)	52	61	66	66	67	76	64.0																																							
Dry Weight (kg):	8.5	23	26	35	44	62	66.5	175																																							
Dimens: (LxWxH-mm)	365x195 x305	430x270 x375	430x285 x390	495x380 x385	505x420 x420	605x495 x485	655x480 x485	965x590 x730																																							
Starting:	Recoil	Recoil	Recoil	Recoil	Recoil	Recoil	Recoil	Electric																																							
Oil Alert:	No	Yes	Yes	Yes	Yes	Yes	Yes	Yes																																							
Ignition:	CDI	Transistor	Transistor	Transistor	Transistor	Transistor	CDI	Transistor																																							
Voltage Regulator:	AVR	BCE	BCE	AVR Yes	AVR	AVR	AVR	AVR																																							
Volt Meter:	No	No	No	No	Yes	Yes	No	Yes																																							
Fuel Gauge:	No	Yes	Yes	No	Yes	No	No	Yes																																							
Circuit Breaker:	Yes	Yes	Yes	Yes	Yes	Yes	Yes	Yes																																							
Auto Throttle:	No	No	No	No	No	No	No	Yes																																							
Pilot Lamp:	Yes	Yes	Yes	No	Yes	No	No	Yes																																							

Honda Outboards



Honda's hard-working, hard-playing lineup of 4-stroke outboard motors are smoother, quieter, and more fuel efficient than comparable 2 strokes, and don't pollute lakes and rivers with oil, either. They're built with Honda's long years of 4-stroke expertise, making them durable and reliable. The perfect choices for powering yachts and pleasure craft, for both freshwater and saltwater.



SPECIFICATIONS	BF15A	BF9.9A	BF8A	BF5A	BF2A
Engine Type:	4-stroke OHC twin	4-stroke OHC twin	4-stroke OHC twin	4-stroke OHV single	4-stroke SV single
Displacement (cm ³):	280	280	197	127	76
Bore x Stroke (mm):	58 x 53	58 x 53	56 x 40	60 x 45	46 x 46
Max. Power (HP/rpm):	15/6,200	9.9/5,500	8/5,500	5/5,000	2/5,000
Cooling System:	Water-cooled	Water-cooled	Water-cooled	Water-cooled	Fan cooled
Ignition System:	CDI	CDI	CDI	Pointless	Pointless
Starting System:	Recoil Elec.*	Recoil Elec.*	Recoil	Recoil	Recoil
Fuel Capacity (lit.):	13	13	13	13	1 (Integrated)
Exhaust:	Propeller boss	Propeller boss	Underwater	Underwater	Underwater
Gear Change:	F-N-R	F-N-R	F-N-R	F-N-R	None-360° pivot
Propeller Size (mm):	240x220 (L)	240x220 (L)	240x220	200 x 190	184 x 120
(Diameter x Pitch):	240x240 (S)	240x240 (S)			
Dimen: L x W (mm)	550 x 320	550 x 320	525 x 315	525 x 340	410 x 275
Height (mm)	1,180/1,050	1,180/1,050	1,160/1,010	1,135/1,005	1,080/930
Transom Height (mm):	570/440	570/440	572/422	572/445	570/420
Dry Weight (kg):	43/42 (47/46)*	43/42 (47/46)*	36.9/35.9	27.5/27	13/12.5
L/S types available					

*Electric starter type

HONDA
POWER EQUIPMENT

Honda Pumps

Honda Tillers



Dependable, versatile and so easy to transport, they move water where you want it. With maximum capacities from 600 lit/min right up to 1300 lit/min you'll find one of the Honda Pumps will suit your needs perfectly, and being Honda four-stroke powered, they'll do the job quietly and economically too.



WD20X



WT20X



WD30X

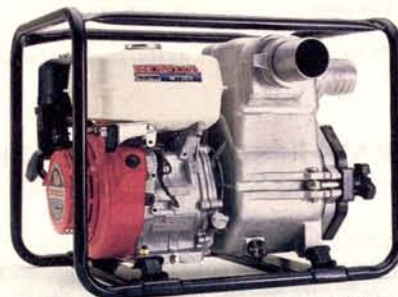

WT30X

SPECIFICATIONS	WD20X	WD30X	WT20X	WT30X
	Centrifugal, self priming	Centrifugal, self priming	Centrifugal, self priming trash pump	Centrifugal, self priming trash pump
Inlet Diameter (mm):	50	80	50	80
Outlet Diameter (mm):	50	80	50	80
Total Head (m):	32	28	26	30
Suction Head (m):	8	8	8	8
Maximum Capacity (litre/min):	600	1100	650	1300
Self Priming Time (sec at 5m):	110/5	150/5	50/5	50/5
Engine:	GX110	GX140	GX140	GX240
Displacement (cm ³):	107	144	144	242
Maximum Output (hp/rpm):	3.5/3,600	5.0/3,600	5/4,000	8/3,600
Fuel Tank Capacity (litres):	2.5	3.6	3.6	6.0
Dimens: (LxWxH-mm):	520x400x450	520x400x490	620x435x405	660x485x510
Dry Weight (kg):	27	32	38	58

For professional and enthusiastic home gardeners alike, the Honda range of power tillers makes gardening a real pleasure. They are all designed to be simple, safe and reliable so that just about anyone becomes an expert from the word go.



F210



F501

FR700

SPECIFICATIONS	F210	F501	FR700
Engine:	GV100 K1	GX140	G300
Maximum Output (HP):	2.4	5.0	7.0
Starting:	Recoil	Recoil	Recoil
Speeds:	1 x F	1 x F	2F/1R
Main Clutch:	Deadman	Deadman	Deadman
Drag Bar:	Yes	Yes	Yes
Front Wheel:	Yes	Yes	No
Dimens: (LxWxH-mm):	1250x585	1320x670	1510x620
	x960	x995	x980
Dry Weight (kg):	29.5	36.0	115
Rotor:	Yes	Yes	Yes
Width of Cut: (mm)	560	610	508

HONDA POWER EQUIPMENT DEALERS

VIC METROPOLITAN

Bayswater
Baybury Mower Centre

Camberwell
Sampsons Honda

Coburg North
Australian Mower Supplies

Dandenong
Dandenong Gippsland Gate Mowers Pty Ltd

Eltham
Bee Vee Honda

Essendon
Precision Mowers Pty Ltd

Ferntree Gully
Jeffrey Sales & Service

Greensborough
Greenvalley Mowers Pty Ltd

Heidelberg
Heidelberg Mowers Pty Ltd

Melton
Jon Kay Agricultural Services

Mentone
Mower City Sales & Service

Mornington
Mornington Power Products

Mt. Waverley
Mt. Waverley Mower Service

Noble Park
Roards Mower Mart

North Melbourne
Symonds Industrial Engines

Ringwood
Morlions Machinery Pty Ltd

South Melbourne
Welling & Crossley Pty Ltd

Sunbury
Town & Country Honda Pty Ltd

Sunshine
Sunshine Motor Mowers Sales & Service

Surrey Hills
Dawn Mowers (Surrey Hills) Pty Ltd

Werribee
Biland Trading Co. Pty Ltd

Whittlesea
K. & J. Thomas

Yarra Glen
Yarra Glen Mower & Tractor Centre

NSW METROPOLITAN

Arncliffe
Usherwood Mower Centre Pty Ltd

Blacktown
A.I.M. Equipment Sales & Service

Castle Hill
Isberg & Muras Pty Ltd

Dee Why
Allmowers

Epping
Vince Duffy Mowers

Fairfield
Jim Airey Motorcycles

Homebush
Fraser Motorcycles

Hornsby
Vince Duffy Mower Sales

Hurstville
Lawrence Bros. Mowers & Sales

Kingsford
Tom Steel Mowers Pty Ltd

Leichhardt
Mentor Motorcycles

Lindfield West
Lindfield Mower Centre Pty Ltd

Liverpool
Honda Southside

Revesby
Costello Mowers & Chainsaws

Sans Souci
Outboard Service Centres (Aust.)

St. Mary's
St. Mary's Mower Centre

Sutherland
Gus Liu Motorcycles Pty Ltd

Sylvania Heights
Rotago

Toongabbie
Edroy Mowers & Chainsaws

Waverley
Bondi Motorcycle Supermarket Pty Ltd

Wentworthville
Girraween Mowers

West Ryde
Lindfield Mower Centre

Westmead
B. R. Booth Pty Ltd

QLD METROPOLITAN

Beenleigh
Norm Fraser (Bris.) Pty Ltd

Booval
Ipswich Honda Centre

Capalaba
Small Engine Centre Redlands

Coopers Plains
Trak Honda

Coorparoo
Peter Uscinski Pty Ltd

Grange
Brisbane Mower Centre

Ipswich
Bob Gartside Bremer St. Mower Sales & Service

Kallangur
Pine Rivers Mowers & Chainsaws

Margate
John Herman's Motor Mowers Sales & Service

Margate
Honda Centre Redcliffe

Slacks Creek
The Mower Market

Strathpine
D. J.'s Mower Service

Windsor
Honda Agencies (Power Equipment)

Woolloongabba
Owen Cox & Co.

Zillmere
Zillmere Mower Centre

SA METROPOLITAN

Adelaide
Houghton Honda

Adelaide
Peter Stevens Motorcycles

Alberton
Seaton Lawn Mowers

Balhannah
Balhannah Motors

Christies Beach
Burns Lawnmower Centre Pty Ltd

Clarence Gardens
Honda World

Clarence Park
All Make Mowers Pty Ltd Sales & Service

Edwardstown
Power Marine

Enfield
The Honda Shop

Gepps Cross
Gepps X Traders

Salisbury
Salisbury Motorcycles

Virginia
United Sales & Service

TAS METROPOLITAN

Hobart
Roberts Ltd

WA METROPOLITAN

Bayswater
Commercial Mower Manufacturer & Rep.

Cannington
Cannington Lawn Mower & C/S.

Hamilton Hill
Westcut Lawnmowers & C/S Sales & Service

Kelmscott
Armada Mower World

Kenwick
Clem Niann Honda

Malaga
Honda Small Motors

Midland
The Honda Shop

Myaree
Spot On Hire

Osborne Park
Sanderson Engineering Co.

Palmyra
Melville Motorcycles Sales & Service

Perth
Hemphill Honda

Perth North
Pal & Panther Cycles & M/C Agency

Southern Cross
Goldfields Bikeworks

Victoria Park East
Trade Equipment

Victoria Park East
Milford Mowers Sales & Service

FOR THE NAME OF YOUR NEAREST RURAL HONDA DEALER

Phone Honda Australia Pty. Ltd. - Melbourne 330 1222, Sydney 684 2399, Perth 458 9811, Brisbane 368 3744, Darwin 81 3827.

MAIL ORDER - To order by mail, simply list the product you require in letter form with your name, address and phone number. Mail this to your local dealer who will contact you regarding pricing, freight costs and despatch details. Your credit card number reference can also be used for payment in most cases.

CREDIT CARDS - Most Honda dealers accept major credit cards.

PRINTED IN AUSTRALIA GNA HG 426 150M 4/89

YOUR HONDA DEALER

In the interests of product development Honda reserve the right to alter specifications and features without notice. Availability of stock depicted in this brochure and colours available may vary from time to time. For complete details please consult your local Honda dealer. Honda Australia Pty. Ltd. incorporated in Victoria.



HONDA
POWER EQUIPMENT

Flexible

PIPE CLEANING TOOLS

PTY. LTD.

The fast, easy, one-man way to Eel-imate clogged drains.

The rugged, professional quality Model C $\frac{3}{4}$ HP Electric Eel[®] machine quickly and easily clears tough stoppages in 3" to 9" lines up to 200' long. Its self-feeding action means you'll never have to touch the rotating cable. There are specially designed cleaning tools for every job and 8' cable sections are inexpensive to repair or replace. Also you and your equipment are protected by an overload safety clutch.

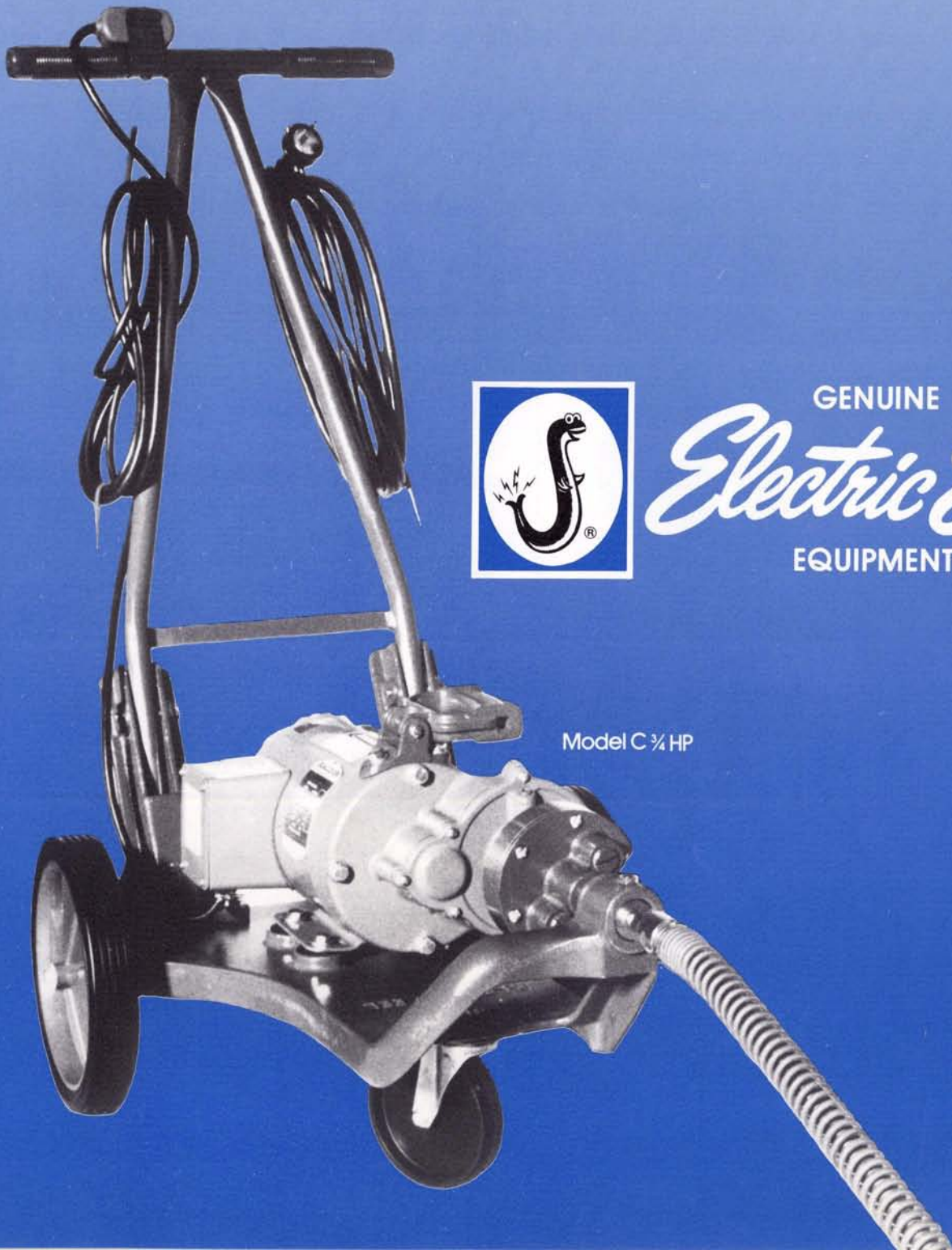

GENUINE
Electric Eel[®]
EQUIPMENT

Model C $\frac{3}{4}$ HP

Heavy duty 'TRS' Dual Cable ...the professional's choice.



Superbly strong and flexible, of dual construction with snap-lock couplings; it makes for easy and reliable use. The extra wire thickness provides many additional months of cable life and ensures a good return on your investment. It may also be repaired.
04 TRS 4ft long x 1 1/4" dia. **08 TRS** 8ft long x 1 1/4" dia. **10 TRS** 10ft long x 1 1/4" dia. (lighter types of cables available on request)



HDD-7 Pick-up tool for broken cables and other items.



A-14DC 3 1/2" Finishing Tool for 4" lines it will negotiate a standard P-trap.



U-3H Heavy Duty Cutter for 3" lines.
U-4H Heavy Duty Cutter for 4" lines.
U-6H Heavy Duty Cutter for 6" lines.



ST-2 Bulb-shaped tool for 4" plastic lines.



HDD-3S Heavy Duty Cutter for 3" lines.
HDD-4S Heavy Duty Cutter for 4" lines.
HDD-5S Heavy Duty Cutter for 6" lines.



SC-19 Drop-head swivel.



HDD-2T 2 3/8" Starting Tool. Flexible leader for negotiating P-traps and making initial opening.



A-1DC 1 7/8" Spade Cutter.
A-2DC 2 3/8" Spade Cutter.
A-2-3DC 3" Spade Cutter.



SC-13 Feeding Tool. This tool is used for feeding cables in or out of pipes or starting cable through traps and bends.



A-6ADC 5" Finishing Tool for 6" lines.



SC-18 Cable Separating Key.

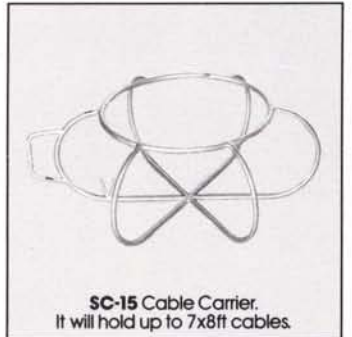

SC-15 Cable Carrier. It will hold up to 7x8ft cables.



GENUINE
Electric Eel®
 EQUIPMENT

Flexible
 PIPE CLEANING TOOLS
PTY LTD

Sold & Serviced by:

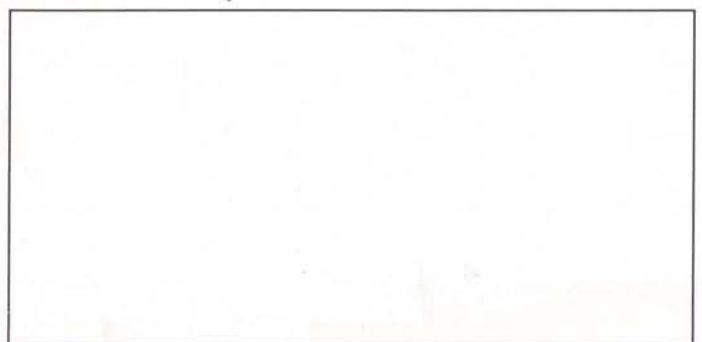

8-10 Palmer Court Mt Waverley Victoria 3149 Australia
 Tel (03) 543 8722 Fax (03) 544 5492 Toll Free (008) 33 5031
 5/9 Blackstone Street Wetherill Park NSW 2164 Australia
 Tel (02) 604 3859 Fax (02) 609 4938 Toll Free (008) 33 5031
 18/433 Logan Road Stones Corner QLD 4120 Australia
 Tel (07) 394 8301 Fax (07) 397 7849 Toll Free (008) 33 5031
 Adelaide Cleaning Equipment 74 Hughes Street Mile End SA
 5031 Australia Tel (08) 234 2007 Fax (08) 234 2008



DECK GUARDRAIL SYSTEMS Pty. Ltd.

Incorporated In Victoria
Telephone: (03) 729 8767

**WorkCare Prevention Award
Perimeter - Deck - Conrail Systems**

Guardrail Systems Wins WorkCare Prevention Award

The Deck Guardrail System

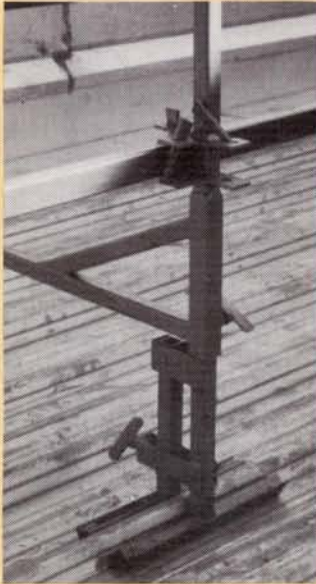

The Deck Guardrail system has been designed for installation after the roof has been laid. This system is easily adapted for erection across or along the roof, and is ideal for use around penetrations in the roof or for maintenance on the roof.

The Deck Guardrail can also be clamped to concrete formwork decking, and is used

extensively in this application.

This system should be erected two metres from any edge of the roof. Workers can install the guardrail system in safety or preferably while the Perimeter Guardrail system is still in position on new buildings.

The Deck Guardrail system has many advantages as listed below:-

- It is easy to erect and dismantle.
- It does not penetrate the roof or concrete decking, other than standard roofing fixings.
- No tool other than a hammer is required to tap the wedges into place to secure the rails.
- It can be used around penetrations in the roof.
- It gives an indication to workers when they are getting close to the edge of the roof.
- Concrete can be laid using the Guardrail to prevent workers from falling over the side of the deck.
- "How to use" brochures are supplied with delivery to site.
- Advice is available when quoting your jobs.

**Patent Pending
Registered Design**

The Perimeter Guardrail System

The Perimeter Guardrail system has been designed for use on steel framed buildings prior to the roof and wall cladding being placed.

The system can be easily used on the gutter line, the gable end, the Apex of single slope roofs, on "T" beams or girts or fascia framing of buildings.

The unique clamping device of this system is readily fixed to "C" and "Z" shaped metal purlins providing a solid base for the easy erection of posts.

A scissor lift or other similar work platform is all that is required to safely erect the guardrail.

The Perimeter Guardrail system has many advantages, as listed below:-

- It does not interfere with the placing of roofing or recessed eaves gutters.
- It is easy to erect and dismantle.
- No tool other than a hammer is required to tap the wedges into place to secure the rails.
- In conjunction with 2mm safety mesh, provides a safe working environment for

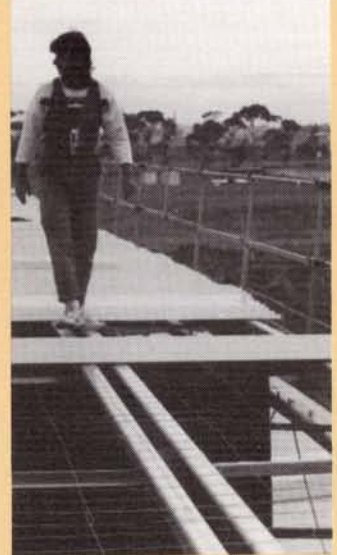

workers.

- It can be used around penetrations in the roof.
- "How to use" brochures are supplied with delivery to site.
- Guardrail can arrange to erect and dismantle.
- Advice is available when quoting your jobs.

**Patent Pending
Registered Design
Applied For**

Conrail Guardrail System

The Conrail Guardrail system has been developed for use on buildings with precast concrete panel walls.

This system has a unique supporting arm which slides into a cavity in the face of the precast concrete wall. The cavity is formed in the wall with specially designed foam blocks which are placed into the panel during the concrete pour. There are two foam blocks, one with a metal bracket which is easily fixed to the formwork for panels poured with the external face down. The second foam block

is for panels poured with the external face up. A hand held foam block is just pushed or vibrated into the face of the panel after the concrete has been screeded.

After the precast concrete panel walls of the building have been erected, a scissor lift or similar work platform is all that is required to safely erect the conrail system.

The Conrail Guardrail has many advantages, as listed below:-

- It does not interfere with the placing of roofing, box gutters



or eaves gutters.

- It allows Apron flashings and cappings to be installed without removing the perimeter protection.
- In conjunction with the 2mm safety mesh, provides a safe working environment for workers.
- It is easy to erect and dismantle.
- No tool other than a hammer is required to tap the wedges into place to secure the rails.

- "How to use" brochures are supplied with delivery to site.
- Advice is available from Guardrail when quoting your jobs.

The Conrail Guardrail system can also be used in precast concrete beams on Hi-Rise buildings, or on bridges under construction to provide edge protection prior to permanent handrails being erected.

Patent Pending

WorkCare Prevention Awards - 29 June 1989

Deck Guardrail Systems - "Safe Working On Roofs"

A steel guard rail developed by two Melbourne men has won a government sponsored award for its contribution to occupational health and safety.

The WorkCare Prevention Award acknowledges contributions to healthier work environments and initiatives that create an awareness and understanding of successful health and safety solutions throughout industry.

The patented Guardrail system uses steel clamps and square section steel posts and rails to provide a strong safety barrier for workers employed on construction site roofs.

It is Australia's first free standing, easy to erect roofing perimeter guardrail.

The Guardrail system was developed by Con Griek and Tony Mitchinson who were working on a construction site when they realised an improved safety system was required if the number of falls from buildings was to be reduced.

It has now been chosen as a model by the Victorian Department of Labour for its 'Code of Practice for Safe Work on Roofs'.

In making the award the department's Director General, Mr Phillip Bentley, gave the following speech.

"I am pleased to be here today on behalf of the Minister for Labour, The Honourable Neil Pope, who unfortunately had to attend another engagement. His task today is a most pleasing one in giving recognition to a company determined to reduce the risks involved in working on roofs.

Tragically, over the last 10 years, 19 deaths have occurred in the roofing industry in which the primary cause appeared to be a significant lack of safety provisions. The policy of the Government of Victoria is to reduce the incidence of workplace or work related injuries

and diseases by a minimum of 10% in the next 10 years.

The WorkCare Prevention Awards are a most important part of that continuing commitment to improve health and safety standards in Victorian workplaces. The Awards represent a positive role for Government in:

- (1) Rewarding innovative people for their ideas which contribute to healthier work environments;
- (2) Promoting awareness and understanding of successful health and safety solutions throughout industry.

Persons or organisations receiving awards have been selected by a judging panel comprising members from unions, industry and Government.

Each application is assessed against the Award criteria, which include:

- (1) Originality;
- (2) Application in the workplace and industry in general;
- (3) Practicability and cost effectiveness;
- (4) Level of consultation with the workers or their representatives in the development of the initiatives.

Deck Guardrail Systems Pty Ltd are worthy winners of an Award. It is Australia's first free standing, easy to erect roofing perimeter guardrail system. It compliments the recently released Code of Practice - "Safe Working on Roofs".

It is well known that one of the major hazards of the roofing industry is that of falling from roofs under construction or from roofs which are being maintained. One of the Directors of this company, Mr Con Griek is a Roof Plumber and as such I am sure he would endorse my comments in this area.

Con Griek along with Tony Mitchinson and Barry Stokes have developed a practical and



Phillip Bentley, Department of Labours Director General (second from left), presents the WorkCare Prevention Award, on behalf of the Minister for Labour, The Hon. Neil Pope, to the directors of Deck Guardrail Systems Pty Ltd, from left, Barry Stokes, Tony Mitchinson and Con Griek.

re-usable perimeter guardrail system to address this problem. This system is usable after the roof has been laid, and on buildings prior to the roof and wall cladding being placed in position. No tools are required as the system uses a unique clamping device for installation.

For roofs already in place workers can install the perimeter system in safety because the attachment method allows it to be installed at any distance, for example 2 metres, from the perimeter. On new roofing installations the roof can be laid without any interference, and when used in conjunction with safety mesh an even safer working environment is created.

I would like to publically endorse this young company for the methods they used to

develop their idea. Advice of all parties within the industry was sought and as such they were able to recognise a problem area and develop a solution pleasing to all groups.

I know the officers in my Building and Construction Division are most enthusiastic about the deckguard rail system's potential to reduce accidents in this dangerous industry. I commend Deck Guardrail Systems Pty Ltd in particular yourselves, Con Griek and Tony Mitchinson, for your ongoing commitment and co-operative efforts in tackling the problem of safety in roof working.

I heartily congratulate you, and without doubt believe you are worthy recipients of this WorkCare Prevention Award."

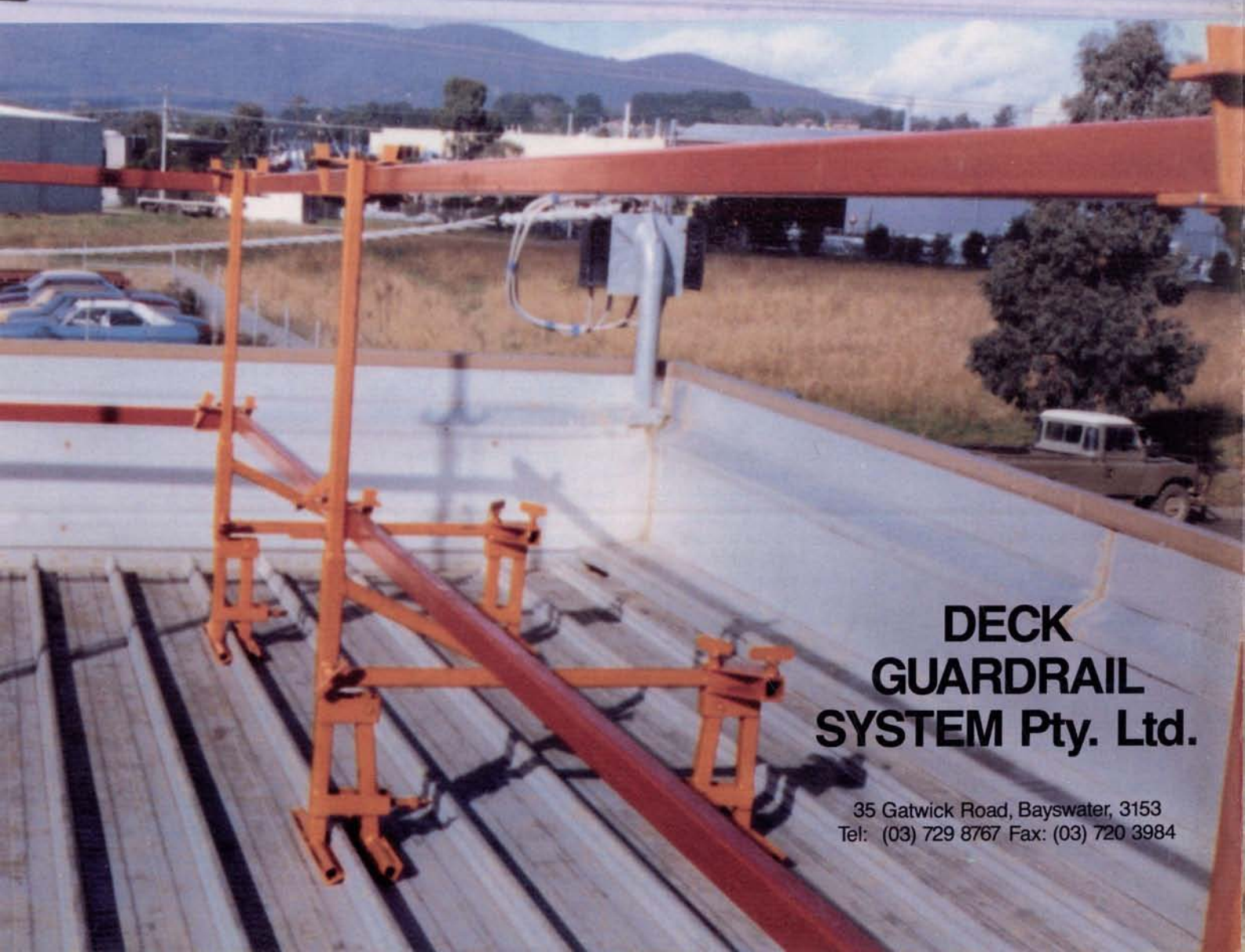

**DECK
GUARDRAIL
SYSTEM Pty. Ltd.**

35 Gatwick Road, Bayswater, 3153
Tel: (03) 729 8767 Fax: (03) 720 3984